



Bestell-Nr. 9900.01.09DE04  
(Bestell-Nr. Betriebsanleitung 9900.01.08DE04)

--	--	--	--	--	--	--	--	--	--

Maschinen-Nr.

Ersatzteilliste

***Mulchsämaschine***

***MegaSeed 3001 S - 6002 K2 Br.3***





Référence 9900.01.09FR04  
(Référence pour notice d'instruction 9900.01.08FR03)

--	--	--	--	--	--	--	--	--	--

Numéro machine

Liste des pièces de rechange

***Semis simplifiés***

***MegaSeed 3001 S - 6002 K2*** Série 3





Order-No. 9900.01.09GB04  
(Order-No. of operating instruction 9900.01.08GB03)

--	--	--	--	--	--	--	--	--	--

Serial number

## Spare Parts List

***Min-Till Seed Drill***

***MegaSeed 3001 S - 6002 K2 Serie 3***





Inhaltsverzeichnis  
Contents  
Sommaire

**MegaSeed Baur. / Serie 3**

<b>A</b>	Deichsel	Drawbar	Timon
<b>A1</b>	Zugpendel	Drawbar eye	Anneau d'attelage
<b>B</b>	Fahrgestell 3,0m	Wheel carrier 3,0m	Porte essieu 3,0m
<b>B1</b>	Fahrgestell 4,0+4,5m	Wheel carrier 4,0+4,5m	Porte essieu 4,0+4,5m
<b>B9</b>	Fahrgestell 6,0m	Wheel carrier 6,0m	Porte essieu 6,0m
<b>B2</b>	Höhen- und Tiefenanzeige 3,0m		
<b>B3</b>	Höhenanzeige ab 4,0m		
<b>B4</b>	Klappzylinder	Folding cylinder	Verin réplage
<b>B5</b>	Tiefenstellzylinder		
<b>B6</b>	Fahrwerkzylinder	Wheel carrier cylinder	Verin porte essieu
<b>B7</b>	Tiefenanzeige ab 4,0m		
<b>B8</b>	Hydraulik f. Fahrwerk	Hydr.pipe for wheel carrier	Hydraulique pour porte essieu
<b>C</b>	Fahrwerk m. Bremsachse	Wheel carrier with brake axle	Porte essieu de frein
<b>C1</b>	Druckluftbremse	Compress.air brake	Freinage pneumatique
<b>C2</b>	Bereifung	Wheels	Roues
<b>D</b>	Zahnpackerwalze 3,0m	Packer roller 3,0m	Rouleau packer 3,0m
<b>D1</b>	Zahnpackerwalze 4,0+4,5m	Packer roller 4,0+4,5m	Rouleau packer 4,0+4,5m
<b>D2</b>	Mulchpackerwalze 3,0m	Mulchpacker roller 3,0m	Rouleau mulchpacker3,0m
<b>D3</b>	Mulchpackerwalze 4,0+4,5m	Mulchpacker roller 4,0+4,5m	Rouleau mulchpacker 4,0+4,5m
<b>D6</b>	Abstreifer-Übersicht MPW 640	View of scrapers	Vue d'ensemble des décroitoirs
<b>D6</b>	Abstreifer-Übersicht RIPA (-M)	View of scrapers	Vue d'ensemble des décroitoirs
<b>E</b>	Mulchscheibensatz 3,0m	Disc unit 3,0m	Disques mulcheur 3,0m
<b>E1</b>	Mulchscheibensatz 4,0+4,5m	Disc unit 4,0+4,5m	Disques mulcheur 4,0+4,5m
<b>E2</b>	Mulchscheiben-Einheit	Disc unit	Disque cpl.



<b>E3</b>	Vibrazinken	Vibra tines	Dents droites
<b>E4</b>	Messerrollegge 3,0m	Rotary tiller 3,0m	Rotoculteur 3,0m
<b>E5</b>	Messerrollegge 4,0m	Rotary tiller 4,0m	Rotoculteur 4,0m
<b>E6</b>	Messerrollegge 4,5m	Rotary tiller 4,5m	Rotoculteur 4,5m
<b>F</b>	Radspurlockerer m.Vibrazinken	Eradicator with vibra tine	Effaceurs de trace avec dent vibro droite
<b>F1</b>	Radspurlockerer m.Kultureggenzinken	Eradicator with S-tine	Effaceurs de trace avec dent vibrante
<b>G</b>	Zinkenschleppe hydr. 3,0m	Leveller hydr. 3,0m	Tôle nivel à crampons 3,0m
<b>G1</b>	Zinkenschleppe hydr. ab 4,0m	Leveller hydr. min.4,0m	Tôle nivel à crampons de 4,0m
<b>H</b>	Beladesteg	Loading platform	Passerelle de chargement
<b>H1</b>	Beladerost	Filling platform	Rampe de chargement
<b>J</b>	Saattank	Hopper	Trémie
<b>J1</b>	Halter	Bracket	Support
<b>J3</b>	Doppeltank 6,0m	Double hopper 6,0m	Double trémie 6,0m
<b>K</b>	Dosierung	Metering unit	Distribution
<b>K1</b>	Verteilereinheit	Distributor head	Tête de répartition
<b>K3</b>	Luftleitung	Air pipe	Conduit d'air
<b>L</b>	Gebläse	Blower	Turbine
<b>L2</b>	Gebläseantrieb Load Sensing	Fan drive Load Sensing	Turbine hydr. Load Sensing
<b>L3</b>	Hydraulik f. Gebläse	Blower hydr.pipe	Hydraulique (turbine)
<b>M</b>	Hydr. f. Schardr., Vorwerkz.3,0m		
<b>M1</b>	Hydraulik f. Schardruck ab 4,0m	Hydr.pipe coulter pressure since 4,0m	Hydraul. pour pression des socs à partir 4,0m

<b>N</b>	Artemis II	Artemis II	Artemis II
<b>O</b>	Säeinheit 3,0m		
<b>O1</b>	Säeinheit 4,0+4,5m		
<b>O2</b>	Säsegment		
<b>O3</b>	Druckrollenarm		
<b>O4</b>	Säeinheit 6,0m		
<b>P</b>	Striegelschiene 3,0m	Harrow rail 3,0m	Plaque de herse 3,0m
<b>P1</b>	Striegelschiene 4,0+4,5m	Harrow rail 4,0+4,5m	Plaque de herse 4,0+4,5m
<b>P2</b>	Striegelschiene 6,0m	Harrow rail 6,0m	Plaque de herse 6,0m
<b>R</b>	Spuranreißer 3,0m	Track marker 3,0m	Traceurs 3,0m
<b>R1</b>	Spuranreißer 4,0+4,5m	Track marker 4,0+4,5m	Traceurs 4,0+4,5m
<b>R2</b>	Hydraulik f. Spuranreisser 3,0m	Hydr.pipe track marker 3,0m	Hydraulique de traceurs 3,0m
<b>R3</b>	Hydraulik f. Spuranreisser 4,0+4,5m	Hydr.pipe track marker	Hydraulique de traceurs
<b>R4</b>	Zylinder f. Spuranreisser	Track marker cylinder	Verin de traceurs
<b>R5</b>	Zylinder f. Fahrgassenmarkier.	Pre-emergence markers cylinder	Verin de jalonnement
<b>S</b>	Fahrgassenmarkierung	Pre-emergence markers	Jalonnement
<b>T</b>	Beleuchtung 3,0m	Light kit 3,0m	Kit d'éclairage 3,0m
<b>T1</b>	Beleuchtung ab 4,0m	Light kit min.4,0m	Kit d'éclairage de 4,0m

**A**

Deichsel  
Drawbar  
Timon

Königsadler, (K), ALS(F) 6000/7500 Br.1, Field Bird, MegaSeed

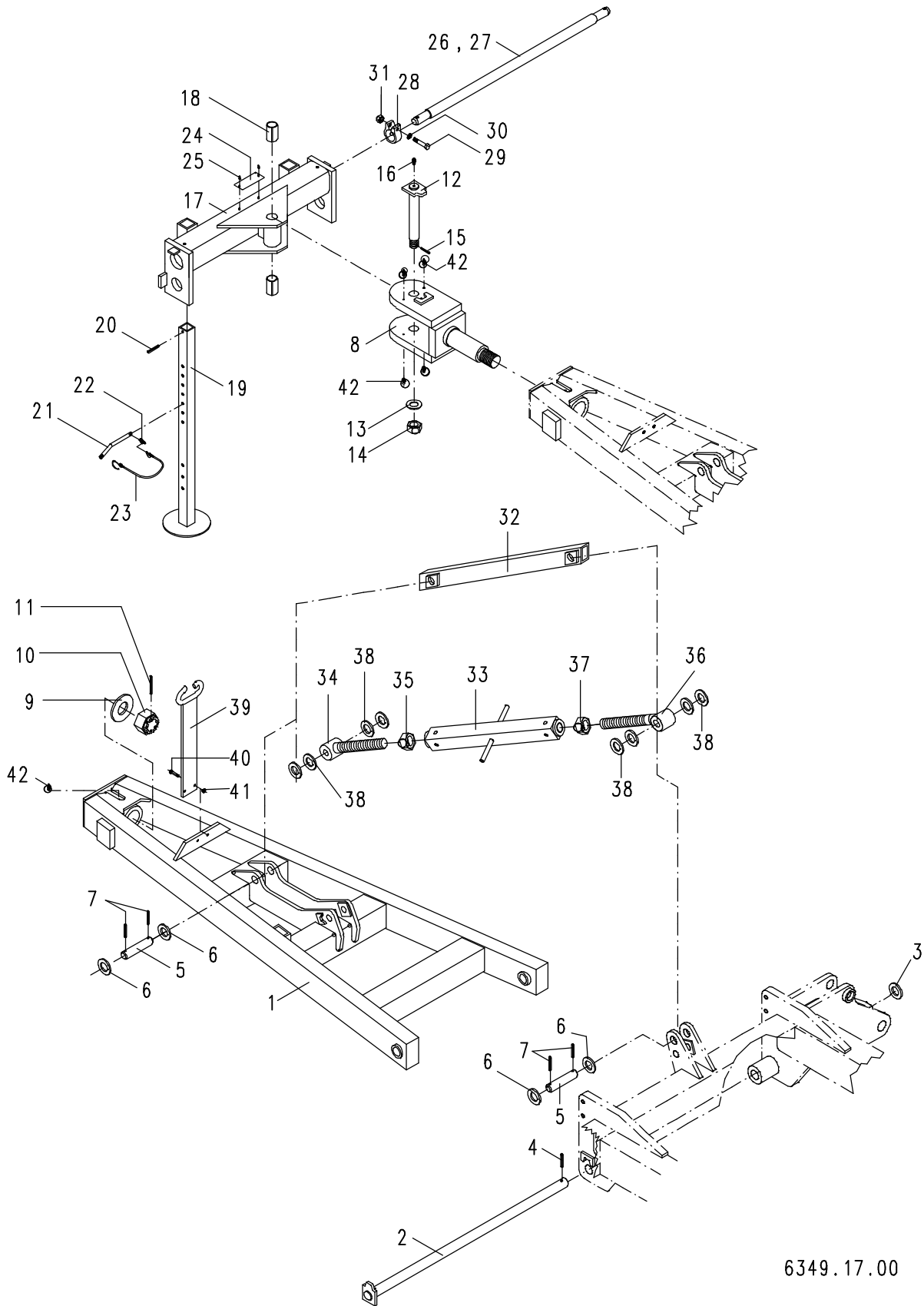

6349.17.00

**A**

 Deichsel  
 Drawbar  
 Timon

**Königsadler (K), ALS(F) 6000/7500 Br.1, Field Bird, MegaSeed**

Bild Ref. Fig.	Bestellnr. Part.-No. Référence	Stck Qty. Qte.	Bezeichnung	Technische Angaben Technical data Données techniques	Description	Désignation
1	6459.97.01	1	Deichsel		Drawbar	Timon
2	6459.09.01	1	Bolzen	L=974 mm	Pin	Axe
3	126D36	1	Scheibe	36 DIN126	Washer	Rondelle
4	1481D1060	1	Spannstift	10x60 DIN1481	Dowel pin	Goupille serrage
5	6459.00.06	2	Bolzen		Pin	Axe
6	1441D31	4	Scheibe	31 DIN1441	Washer	Rondelle
7	1481D850	4	Spannstift	8x50 DIN1481	Dowel pin	Goupille serrage
8	6332.36.10	1	Gelenkstück		Swivel	Pivot
9	6349.10.01	1	Scheibe		Washer	Rondelle
10	935D4815P	1	Kronenmutter	M48X1,5 DIN935-8	Castellated nut	Ecrou crênelé
11	1481D870	1	Spannstift	8x70 DIN1481	Dowel pin	Goupille serrage
12-16	6459.47.00	1	GELENKBOLZEN KPL.		PIN CPL.	BROCHE CPL.
12	6459.47.01	1	Gelenkbolzen		Pin	Broche
13	6916D31	1	Scheibe	31 DIN6916	Washer	Rondelle
14	937D3015P	1	Kronenmutter	M30x1,5 DIN937-8	Castellated nut	Ecrou crênelé
15	1481D645	1	Spannstift	6x45 DIN1481	Dowel pin	Goupille serrage
16	4716.38.00	1	Schmiernippel	H1 8x1 KX-1	Grease nipple	Graisser
17-18	6332.37.15	1	ACHSLAGER MONT.	Ø64 mm	HOUSING+BUSHES	POTENCE BAQUE
17	6332.37.14	1	Achslager mit Bohrung	Ø64	Housing	Potence
18	1498D354060	2	Buchse	EG 35/40x60 DIN1498	Bush	Douille
19	6611.22.05	2	Abstellstütze		Stand	Bequille
20	1481D860A	2	Spannstift	8x60 DIN1481 vz.	Dowel pin	Goupille serrage
21	9001.70.20	2	Steckbolzen		Pin	Axe
22	8405.12.09	2	Klappstecker	STB-4,5x340	Linch-pin	Goupille auto.
23	8163.07.01	2	Sicherungsband		Safety strap	Caotchouc
24	4716.37.00	1	Typenschild	SX-4	ID-plate	ID-plaque
25	1476D410	2	Halbrundkerbnagel	4x10 DIN1476	Rivet	Rivet
26	2607.26.00	1	Dreipunktachse	Kat.3	3-point shaft	Axe 3-points
27	2607.28.01	1	Dreipunktachse	K700	3-point shaft	Axe 3-points
28	4346.35.00	2	Klemmring	UW-82	Clamping ring	Bague de serrage
29	931D1680P	2	Sechskantschraube	M16x80 DIN931- 8.8	Hex. bolt	Vis 6 pans
30	127DB16A	2	Federring	B16 DIN127 verz.	Springwasher	Rondelle grower
31	934D16PA	2	Sechskantmutter	M16 DIN934-8 verz.	Hex. nut	Ecrou 6 pans
32	6459.54.01	1	Deichselstrebe		Link	Barre



**A1**

Zugpendel

Draw bar eye Königsadler (K), ALS(F) 6000/7500 Br.1, Field Bird, MegaSeed

Anneau d'attelage

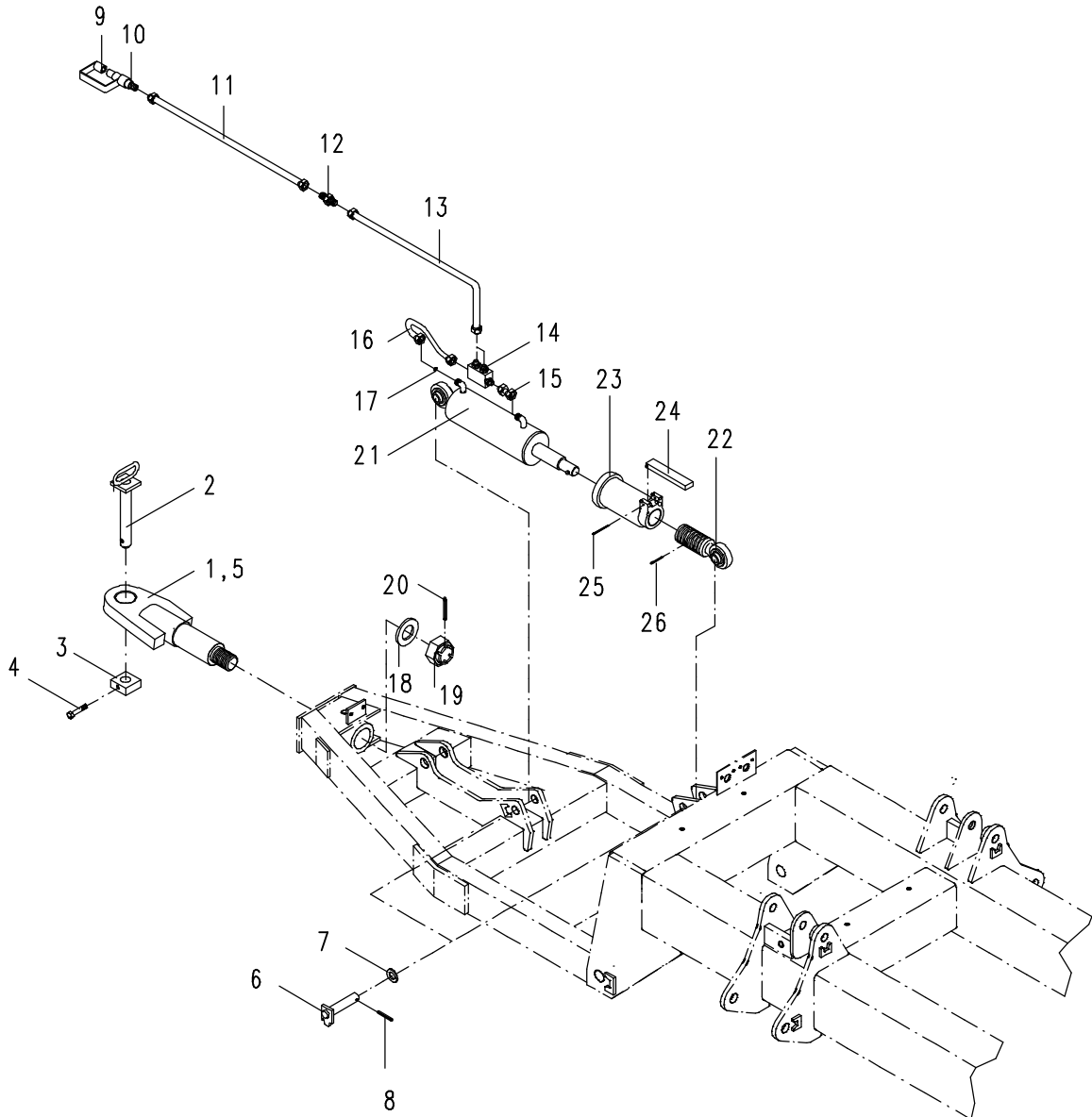



**A1**

Zugpendel  
Drawbar eye  
Anneau d'attelage

**Königsadler (K), ALS(F) 6000/7500 Br.1, Field Bird, MegaSeed**

Bild Ref. Fig.	Bestellnr. Part.-No. Référence	Stck Qty. Qte.	Bezeichnung	Technische Angaben Technical data Données techniques	Description	Désignation
1-27	6349.17.01	1	ZUGPENDEL	Ø41 MM	DRAWBAR EYE	ANNEAU D'ATTELAGE
5-27	6349.17.02	1	ZUGPENDEL	Ø58 MM	DRAWBAR EYE	ANNEAU D'ATTELAGE
.	.	.	.	.	.	.
1	6349.15.03	1	Gelenkstück	Ø41 mm	Swivel	Pivot
2	6442.16.05	1	Zugbolzen		Pin	Axe
3	6442.16.04	1	Bolzensicherung		Safety pin	Sécurité
4	931D1260P	1	Sechskantschraube	M12x60 DIN931-8.8	Hex. bolt	Vis 6 pans
5	6349.15.04	1	Gelenkstück	Ø58 mm	Swivel	Pivot
6	8018.66.09	2	Bolzen		Pin	Axe
7	1441D26	2	Scheibe	26 DIN1441	Washer	Rondelle
8	1481D840A	2	Spannstift	8x40 DIN1481 vz.	Dowel pin	Goupille serrage
9	8132.05.01	2	Staubschutzkappe, rot		Dust cap red	Cache rouge
10	8132.01.00	2	Kupplungsstecker	ISO 5675	Coupling	Raccord
11	8413.88.01	2	Höchstdruckschlauch	L=1500 mm	Hose	Conduite flexible
12	4716.52.13	2	Gerade Verschraubung	G 12-L	Male stud coupling	Raccord
13	4716.46.06	2	Höchstdruckschlauch	L=1000 mm	Hose	Conduite flexible
14	8154.24.02	1	Doppelrückschlagventil		Valve	Limiteur
15	4716.53.05	1	Hydraulikrohr kpl.	L=40 mm	Hydr.pipe cpl.	Tube cpl.
16	6349.20.01	1	Hydraulikrohr mont.	L=275 mm	Hydr.pipe	Tube
17	8132.06.02	1	Drosselscheibe	Ø1,5	Restrictive washer	Etranglement
18	6349.10.01	1	Scheibe		Washer	Rondelle
19	935D4815P	1	Kronenmutter	M48X1,5 DIN935-8	Castellated nut	Ecrou crénelé
20	1481D870	1	Spannstift	8x70 DIN1481	Dowel pin	Goupille serrage
.	.	.	.	.	.	.
21-26	8166.04.02	1	ZYLINDER VERSTELLB.		CYLINDER	VERIN
21	8166.07.01	1	ZYLINDER KPL.	90/40/200	Cylinder	Verin
22	8154.37.01	1	Kugelkopf m.Gewindehülse		Ball joint	Joint à rotule
23	8127.31.04	1	Verstellung		Adjuster	Réglage
24	8127.33.01	1	Riegel		Lock	Verrou
25	1481D660	1	Spannstift	6x60 DIN1481	Dowel pin	Goupille serrage
26	1481D840A	1	Spannstift	8x40 DIN1481 vz.	Dowel pin	Goupille serrage
27	8166.02.16	2	Reduzierhülse		Bush	Baque
.	8166.03.03	1	Dichtungssatz		Seal kit	Jeu de jointe
.	.	.	.	.	.	.
.	.	.	.	.	.	.
.	.	.	.	.	.	.
.	.	.	.	.	.	.
.	.	.	.	.	.	.

B

Fahrgestell  
Wheel carrier  
Porte essieu

MegaSeed 3001 S

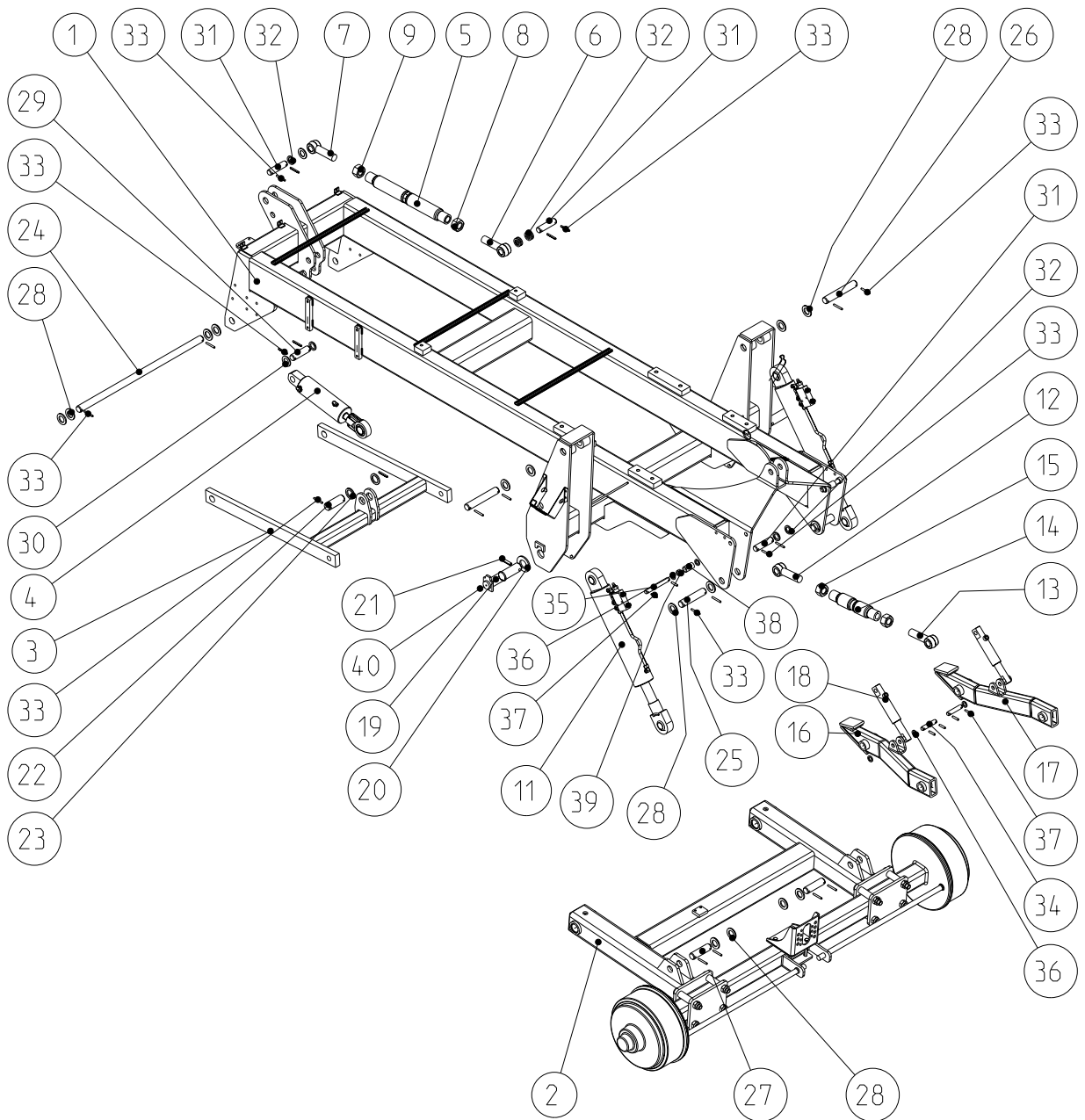



**B**

Fahrgestell  
Wheel carrier  
Porte essieu

**MegaSeed 3001 S**

Bild Ref. Fig.	Bestellnr. Part.-No. Référence	Stck Qty. Qte.	Bezeichnung	Technische Angaben Technical data Données techniques	Description	Désignation
	9031.00.01	1	FAHRGESTELL	3,0m	WHEEL CARRIER	PORTE ESSIEU
1	9031.02.00	1	Grundrahmen	3,0m	Frame	Bâti de base
2	6464.10.00	1	FAHRWERK+BREMSACHS		Wheel carrier	Porte essieu
3	9031.02.80	1	Zwischenrahmen		Interm. Beam	Bâti intermédiaire
4	8168.07.10	1	ZYLINDER KPL..	80/65/168		
5-9	6442.22.21	1	SPANNSCHLOSS KPL.	M36		
5	6442.22.20	1	Spannschloßmutter	M36		
6	4782.35.05	1	Gewindeende	M36 L	Eyebolt	Piton fileté
7	4782.35.06	1	Gewindeende	M36	Eyebolt	Piton fileté
8	934D36PA	1	Sechskantmutter	M36 DIN934-8 vz.	Hex. nut	Ecrou 6 pans
9	934D36PAL	1	Sechskantmutter	M36 L DIN934-8 vz.	Hex. nut	Ecrou 6 pans
11	8172.04.01	2	ZYLINDER KPL.	90/45/405/730		
12-15	4782.35.08	1	SPANNSCHLOSS KPL.	M36	TURNBUCKLE CPL.	TIRANT CPL.
12	4782.35.05	1	Gewindeende	M36 L	Eyebolt	Piton fileté
13	4782.35.06	1	Gewindeende	M36	Eyebolt	Piton fileté
14	4782.35.04	1	Spannschloßmutter	M36	Turnbuckle nut	Ecrou tendeur
15	934D36PA	1	Sechskantmutter	M36 DIN934-8 vz.	Hex. nut	Ecrou 6 pans
16	9031.19.02	1	Unterlenker, links			
17	9031.19.01	1	Unterlenker, rechts			
18	8171.08.01	2	ZYLINDER KPL.	40/85/215	CYLINDER CPL.	VERIN CPL.
19	9017.41.01	2	Bolzen	Ø45 mm	Pin	Axe
20	125DA46A	2	Scheibe	A46 DIN125 vz.	Washer	Rondelle
21	1481D1370A	2	Spannstift	13x70 DIN1481 vz.	Dowel pin	Goupille serrage
22	1000.03.06	1	Bolzen	Ø40 mm	Pin	Axe
23	1441D41A	2	Scheibe	41 DIN1441 vz.	Washer	Rondelle
24	1000.12.01	1	Bolzen	Ø35 mm	Pin	Axe
25	1000.13.12	2	Bolzen	Ø35 mm	Pin	Axe
26	1000.13.04	2	Bolzen	Ø35 mm	Pin	Axe
27	1000.13.03	2	Bolzen	Ø35 mm	Pin	Axe
28	126D36A	16	Scheibe	36 DIN126 vz.		
29	1000.02.03	1	Bolzen	Ø32 mm	Pin	Axe
30	126D33A	2	Scheibe	33 DIN126 vz.	Washer	Rondelle
31	1000.16.01	3	Bolzen	Ø30 mm	Pin	Axe

**B**

 Fahrgestell  
 Wheel carrier  
 Porte essieu

**MegaSeed 3001 S**

Bild Ref. Fig.	Bestellnr. Part.-No. Référence	Stck Qty. Qte.	Bezeichnung	Technische Angaben Technical data Données techniques	Description	Désignation
32	1441D31A	8	Scheibe	31 DIN1441 vz.	Washer	Rondelle
33	1481D860A	24	Spannstift	8x60 DIN1481 vz.	Dowel pin	Goupille serrage
34	1000.20.01	2	Bolzen	Ø20 mm	Pin	Axe
35	1000.20.02	2	Bolzen	Ø20 mm	Pin	Axe
36	1441D21A	8	Scheibe	21 DIN1441 vz.	Washer	Rondelle
37	1481D840A	8	Spannstift	8x40 DIN1481 vz.	Dowel pin	Goupille serrage
38	NR3045X54	2	Rohr	L=54 mm	Pipe	Tube
39	NR3045X14	2	Rohr	L=14 mm	Pipe	Tube
40	4716.38.00	2	Schmiernippel	H1 8x1 KX-1	Grease nipple	Graisser
.	.	.	.	.	.	.
.	.	.	.	.	.	.
.	.	.	.	.	.	.
.	.	.	.	.	.	.
.	.	.	.	.	.	.
.	.	.	.	.	.	.
.	.	.	.	.	.	.
.	.	.	.	.	.	.
.	.	.	.	.	.	.
.	.	.	.	.	.	.
.	.	.	.	.	.	.
.	.	.	.	.	.	.
.	.	.	.	.	.	.
.	.	.	.	.	.	.
.	.	.	.	.	.	.
.	.	.	.	.	.	.
.	.	.	.	.	.	.
.	.	.	.	.	.	.
.	.	.	.	.	.	.
.	.	.	.	.	.	.
.	.	.	.	.	.	.
.	.	.	.	.	.	.
.	.	.	.	.	.	.
.	.	.	.	.	.	.
.	.	.	.	.	.	.
.	.	.	.	.	.	.
.	.	.	.	.	.	.
.	.	.	.	.	.	.
.	.	.	.	.	.	.

B1

Fahrgestell  
Wheel carrier  
Porte essieu

MegaSeed 4001 K2, 4501 K2

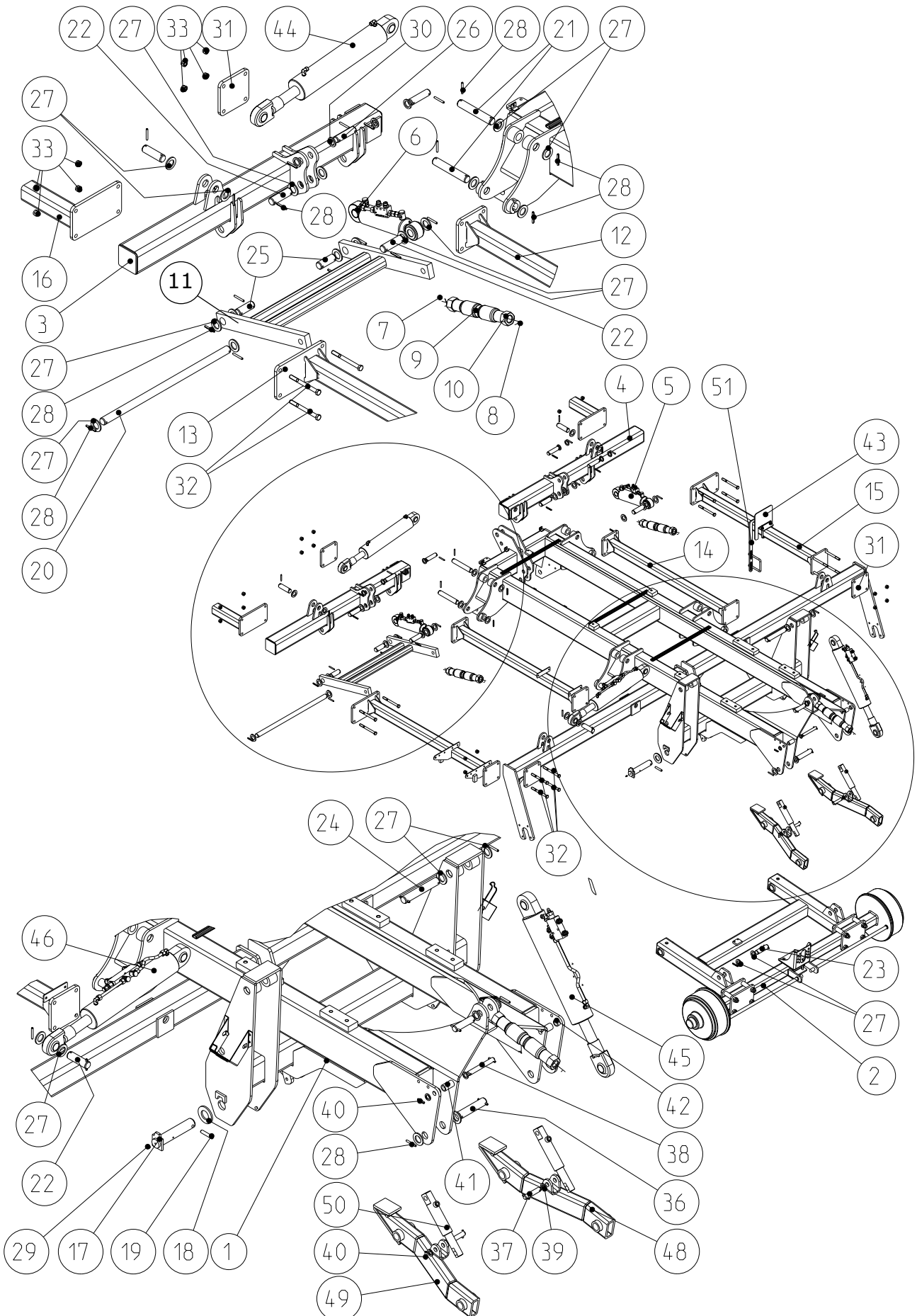



**B1**

Fahrgestell  
Wheel carrier  
Porte essieu

**MegaSeed 4001 K2, 4501 K2**

Bild Ref. Fig.	Bestellnr. Part.-No. Référence	Stck Qty. Qte.	Bezeichnung	Technische Angaben Technical data Données techniques	Description	Désignation
	9031.00.02	1	FAHRGESTELL	4,0m	WHEEL CARRIER	PORTE ESSIEU
	9031.00.03	1	FAHRGESTELL	4,5m	WHEEL CARRIER	PORTE ESSIEU
1	9031.02.01	1	Grundrahmen		Frame	Bâti de base
2	6464.10.00	1	FAHRWERK+BREMSACHS		Wheel carrier	Porte essieu
3	9032.07.01	1	Rahmen, vorn links		Front beam l.h.	Bâti avant gauche
4	9032.07.02	1	Rahmen, vorn rechts		Front beam r.h.	Bâti avant droit
5	8172.04.11	1	ZYLINDER, RECHTS KPL.		CYLINDER R.H. CPL.	VERIN DROIT CPL.
6	8172.04.12	1	ZYLINDER, LINKS KPL.		CYLINDER L.H. CPL.	VERIN GAUCHE CPL.
7-10	4782.35.08	3	SPANNSCHLOSS KPL.	M36	TURNBUCKLE CPL.	TIRANT CPL.
7	4782.35.05	3	Gewindeende	M36 L	Eyebolt	Piton filete
8	4782.35.06	3	Gewindeende	M36	Eyebolt	Piton filete
9	4782.35.04	3	Spannschloßmutter	M36	Turnbuckle nut	Ecrou tendeur
10	934D36PA	3	Sechskantmutter	M36 DIN934-8 vz.	Hex. nut	Ecrou 6 pans
11	9032.09.01	2	Verbindungsrahmen		Connecting frame	Bâti assembl.
12	9032.14.01	1	Anlenkung, innen		Link arm	Bras réglable
13	9032.14.02	1	Anlenkung, außen	4,0m	Link arm	Bras réglable
13	9032.14.04	1	Anlenkung, außen	4,5m	Link arm	Bras réglable
14	9032.08.01	1,2	Zwischenrahmen		Interm. Beam	Bâti intermédiaire
15	9032.14.03	1	Zwischenrahmen, außen	4,0m		
16	9031.06.66	1	Spuranreißeranlenkung	4,0m		
16	9031.06.65	1	Spuranreißeranlenkung	4,5m		
17	9017.41.01	2	Bolzen	Ø45 mm	Pin	Axe
18	125DA46A	2	Scheibe	A46 DIN125 vz.	Washer	Rondelle
19	1481D1370A	2	Spannstift	13x70 DIN1481 vz.	Dowel pin	Goupille serrage
20	1000.13.01	1	Bolzen	Ø35 mm	Pin	Axe
21	1000.13.02	8	Bolzen	Ø35 mm	Pin	Axe
22	1000.13.06	8	Bolzen	Ø35 mm		
23	1000.13.03	2	Bolzen	Ø35 mm	Pin	Axe
24	1000.13.04	2	Bolzen	Ø35 mm	Pin	Axe
25	1000.13.05	4	Bolzen	Ø35 mm	Pin	Axe
26	1000.16.01	5	Bolzen	Ø30 mm	Pin	Axe
27	126D36A	66	Scheibe	36 DIN126 vz.		



**B1**

Fahrgestell  
Wheel carrier  
Porte essieu

**MegaSeed 4001 K2, 4501 K2**

Bild Ref. Fig.	Bestellnr. Part.-No. Référence	Stck Qty. Qte.	Bezeichnung	Technische Angaben Technical data Données techniques	Description	Désignation
28	1481D860A	64	Spannstift	8x60 DIN1481 vz.	Dowel pin	Goupille serrage
29	4716.38.00	2	Schmiernippel	H1 8x1 KX-1	Grease nippel	Graisser
30	1441D31A	10	Scheibe	31 DIN1441 vz.	Washer	Rondelle
31	9032.08.20	6	Endplatte		Plate	Plaquette
32	931D16170PA	32	Sechskantschraube	M16x170 DIN931-8.8	Hex.bolt	Vis 6 pans
33	985D16PA	32	Sechskantmutter	M16 DIN985-8 vz.	Hex. nut	Ecrou 6 pans
36	1000.13.12	2	Bolzen	Ø35 mm	Pin	Axe
37	1000.20.01	2	Bolzen	Ø20 mm	Pin	Axe
38	1000.20.02	2	Bolzen	Ø20 mm	Pin	Axe
39	1441D21A	8	Scheibe	21 DIN1441 vz.	Washer	Rondelle
40	1481D840A	8	Spannstift	8x40 DIN1481 vz.	Dowel pin	Goupille serrage
41	NR3045X54	2	Rohr	L=54 mm	Pipe	Tube
42	NR3045X14	2	Rohr	L=14 mm	Pipe	Tube
43	6464.00.30	1	TIEFENANZEIGE MONT.			
44	8166.08.01 8166.02.13	2	ZYLINDER KPL. Dichtungssatz	90/45/405/730	CYLINDER CPL. Seal kit	VERIN CPL. Jeu de joints
45	8172.04.01	2	ZYLINDER KPL.	90/45/405/730		
46	8172.04.02	2	KLAPPZYLINDER KPL.		FOLDING CYLINDER	VERIN REPLIAGE CPL.
48	9031.19.01	1	Unterlenker, rechts			
49	9031.19.02	1	Unterlenker, links			
50	8171.08.01 8171.02.03	2	ZYLINDER KPL. Dichtungssatz	40/85/215	CYLINDER CPL. Seal kit	VERIN CPL. Jeu de joints
51	6464.11.01	1	HÖHENANZEIGE MONT.			

B9

Fahrgestell  
Wheel carrier  
Porte essieu

MegaSeed 6002 K 2 Br./ Serie 3

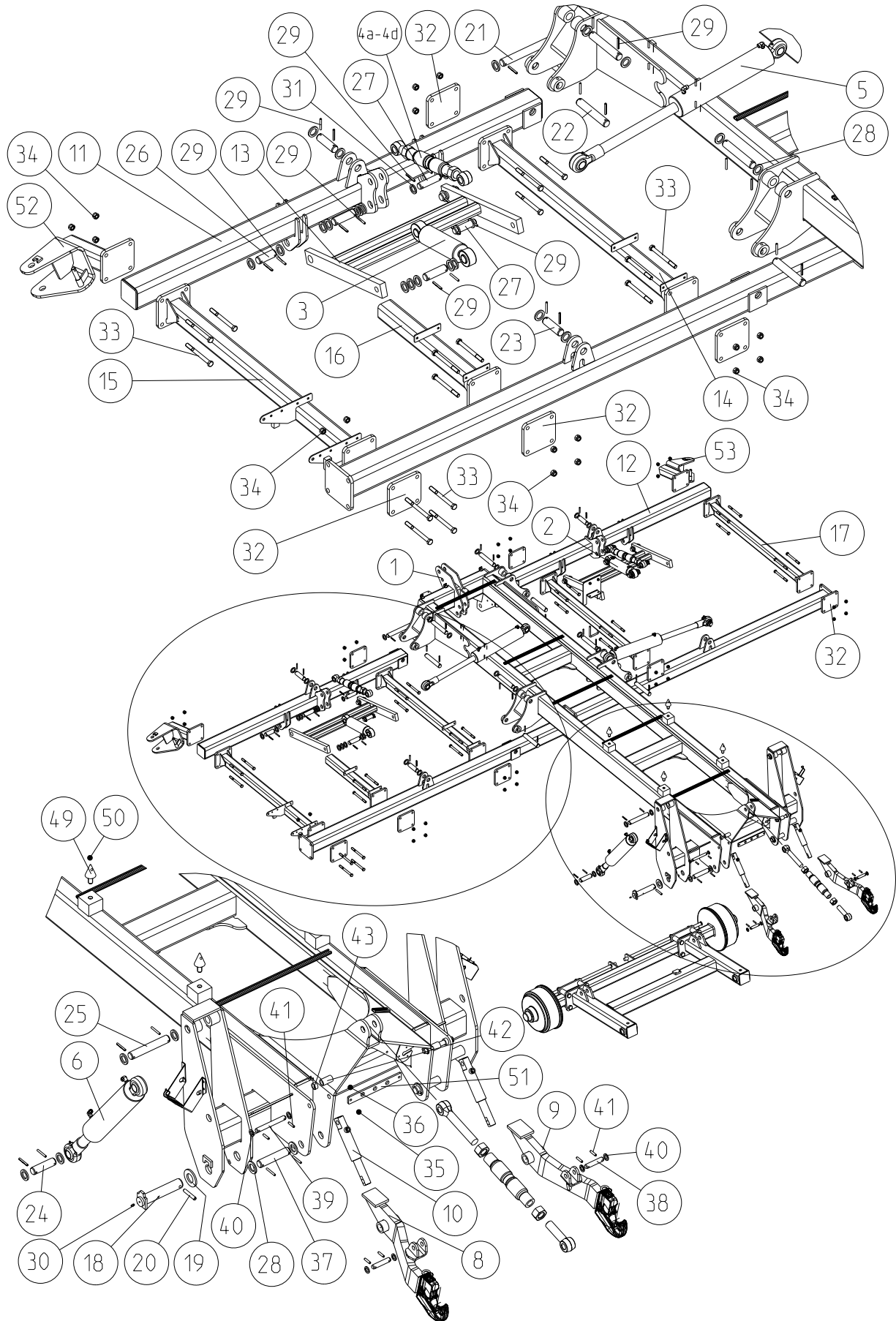

**B9**

 Fahrgestell  
 Wheel carrier  
 Porte essieu

**MegaSeed 6002 K2 Br./Serie 3**

Bild Ref. Fig.	Bestellnr. Part.-No. Référence	Stck Qty. Qte.	Bezeichnung	Technische Angaben Technical data Données techniques	Description	Désignation
1	9031.02.02	1	Grundrahmen	6,0m	Frame	Bâti de base
2	8172.04.11	1	ZYLINDER, RECHTS KPL.		CYLINDER R.H. CPL.	VERIN DROIT CPL.
3	8172.04.12	1	ZYLINDER, LINKS KPL.		CYLINDER L.H. CPL.	VERIN GAUCHE CPL.
4a-4d	4782.35.08	3	SPANNSCHLOSS KPL.	M36	TURNBUCKLE CPL.	TIRANT CPL.
4a	4782.35.05	1	Gewindeende	M36 L	Eyebolt	Piton filete
4b	4782.35.06	1	Gewindeende	M36	Eyebolt	Piton filete
4c	4782.35.04	1	Spannschloßmutter	M36	Turnbuckle nut	Ecrou tendeur
4d	934D36PA	1	Sechskantmutter	M36 DIN934-8 vz.	Hex. nut	Ecrou 6 pans
5	8172.04.02	4	KLAPPZYLINDER KPL.		FOLDING CYLINDER	VERIN REPLIAGE CPL.
6	8172.04.01	2	ZYLINDER KPL.	90/45/405/730		
8	9031.19.70	1	Unterlenker, links		Lower link l.h.	Interieur gauche
9	9031.19.71	1	Unterlenker, rechts		Lower link r.h.	Interieur droit
10	8171.08.01	2	ZYLINDER KPL.	40/85/215	CYLINDER CPL.	VERIN CPL.
	8171.02.03	1	Dichtungssatz		Seal kit	Jeu de joints
11	9032.07.05	1	Rahmen, vorn links		Front beam l.h.	Bâti avant gauche
12	9032.07.06	1	Rahmen, vorn rechts		Front beam r.h.	Bâti avant droit
13	9032.09.01	2	Verbindungsrahmen		Connecting frame	Bâti assembl.
14	9032.14.01	1	Anlenkung, innen		Link arm	Bras réglable
15	9032.14.04	1	Anlenkung, außen	4,5m+6,0m	Link arm	Bras réglable
16	9032.14.30	1	Anlenkung, innen links		Link arm l.h.	Bras réglable gauche
17	9032.08.01	2	Zwischenrahmen		Interm. Beam	Bâti intermédiaire
18	9017.41.01	2	Bolzen	Ø45 mm	Pin	Axe
19	125DA46A	2	Scheibe	A46 DIN125 vz.	Washer	Rondelle
20	1481D1370A	2	Spannstift	13x70 DIN1481 vz.	Dowel pin	Goupille serrage
21	1000.13.01	1	Bolzen	Ø35 mm	Pin	Axe
22	1000.13.02	8	Bolzen	Ø35 mm	Pin	Axe
23	1000.13.06	8	Bolzen	Ø35 mm	Pin	Axe
24	1000.13.03	2	Bolzen	Ø35 mm	Pin	Axe
25	1000.13.04	2	Bolzen	Ø35 mm	Pin	Axe
26	1000.13.05	4	Bolzen	Ø35 mm	Pin	Axe
27	1000.16.01	5	Bolzen	Ø30 mm	Pin	Axe
28	126D36A	58	Scheibe	36 DIN126 vz.		



**B9**

Fahrgestell  
Wheel carrier  
Porte essieu

**MegaSeed 6002 K2 Br./Serie 3**

Bild Ref. Fig.	Bestellnr. Part.-No. Référence	Stck Qty. Qte.	Bezeichnung	Technische Angaben Technical data Données techniques	Description	Désignation
29	1481D860A	56	Spannstift	8x60 DIN1481 vz.	Dowel pin	Goupille serrage
30	4716.38.00	2	Schmiernippel	H1 8x1 KX-1	Grease nipple	Graisneur
31	1441D31A	10	Scheibe	31 DIN1441 vz.	Washer	Rondelle
32	9032.08.20	6	Endplatte		Plate	Plaquette
33	931D16170PA	32	Sechskantschraube	M16x170 DIN931-8.8 vz.	Hex.bolt	Vis 6 pans
34	985D16PA	32	Sechskantmutter	M16 DIN985-8 vz.	Hex.nut	Ecrou 6 pans
35	931D830PA	2	Sechskantschraube	M8x30 DIN931-8.8 vz.	Hex.bolt	Vis 6 pans
36	985D8PA	2	Sechskantmutter	M8 DIN985-8 vz.	Hex.nut	Ecrou 6 pans
37	1000.13.12	2	Bolzen	Ø35 mm	Pin	Axe
38	1000.20.01	2	Bolzen	Ø20 mm	Pin	Axe
39	1000.20.02	2	Bolzen	Ø20 mm	Pin	Axe
40	1441D21A	8	Scheibe	21 DIN1441 vz.	Washer	Rondelle
41	1481D840A	8	Spannstift	8x40 DIN1481 vz.	Dowel pin	Goupille serrage
42	NR3045X54	2	Rohr	L=54 mm	Pipe	Tube
43	NR3045X14	2	Rohr	L=14 mm	Pipe	Tube
44	1481D875A	8	Spannstift	8x75 DIN1481 vz.	Dowel pin	Goupille serrage
49	9032.02.31	4	Verriegelungszapfen		Blocking pin	Axe verrouillage
50	6805.00.17	4	Kommerzstecker	Ø9,5 vz.	Linch pin	Goupille
51	9031.02.90	1	Halter		Bracket	Support
52	9032.67.01	1	Spurreisseranlenkung, links		Link arm l.h.	Bras gauche
53	9032.67.02	1	Spurreisseranlenkung, rechts		Link arm r.h.	Bras droit
.	.	.	.	.	.	.
.	.	.	.	.	.	.
.	.	.	.	.	.	.
.	.	.	.	.	.	.
.	.	.	.	.	.	.
.	.	.	.	.	.	.
.	.	.	.	.	.	.
.	.	.	.	.	.	.
.	.	.	.	.	.	.
.	.	.	.	.	.	.
.	.	.	.	.	.	.
.	.	.	.	.	.	.
.	.	.	.	.	.	.
.	.	.	.	.	.	.
.	.	.	.	.	.	.

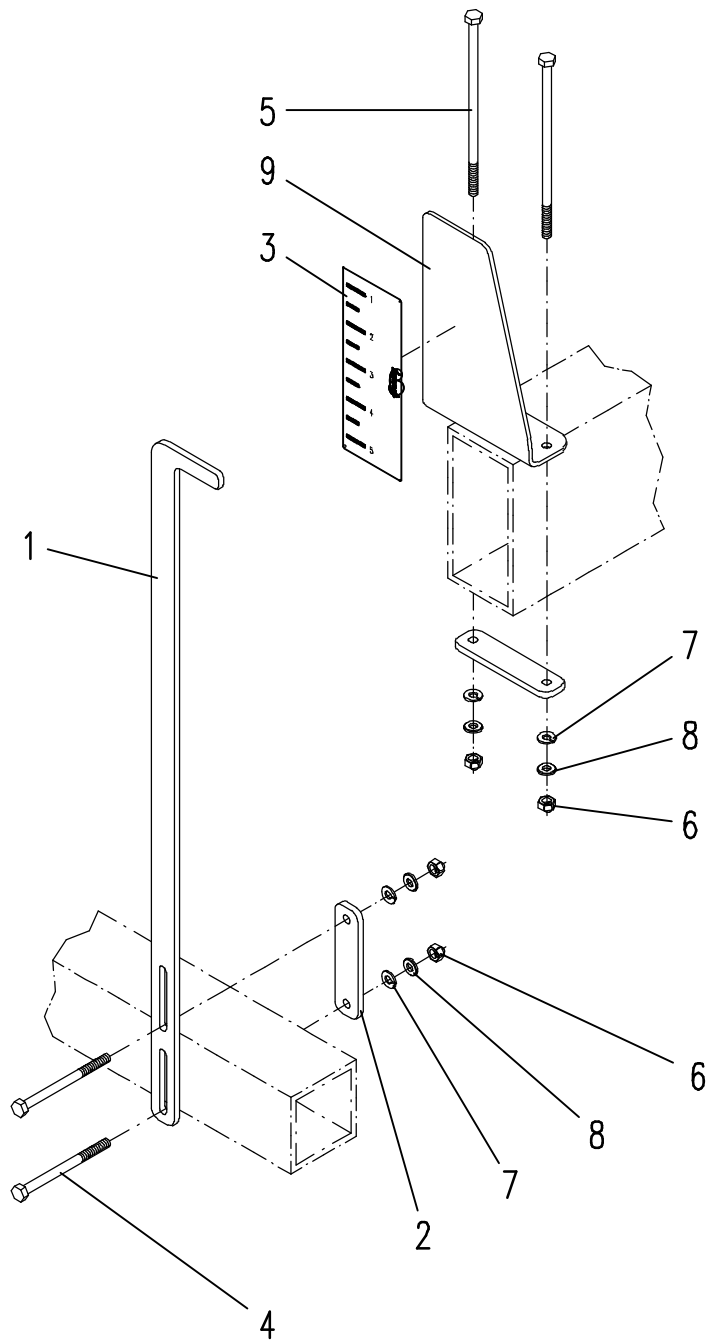



B3

Höhenanzeige  
#  
#

MegaSeed ab/min./de. 4,0m, Field Bird ab/min./de 4,5m

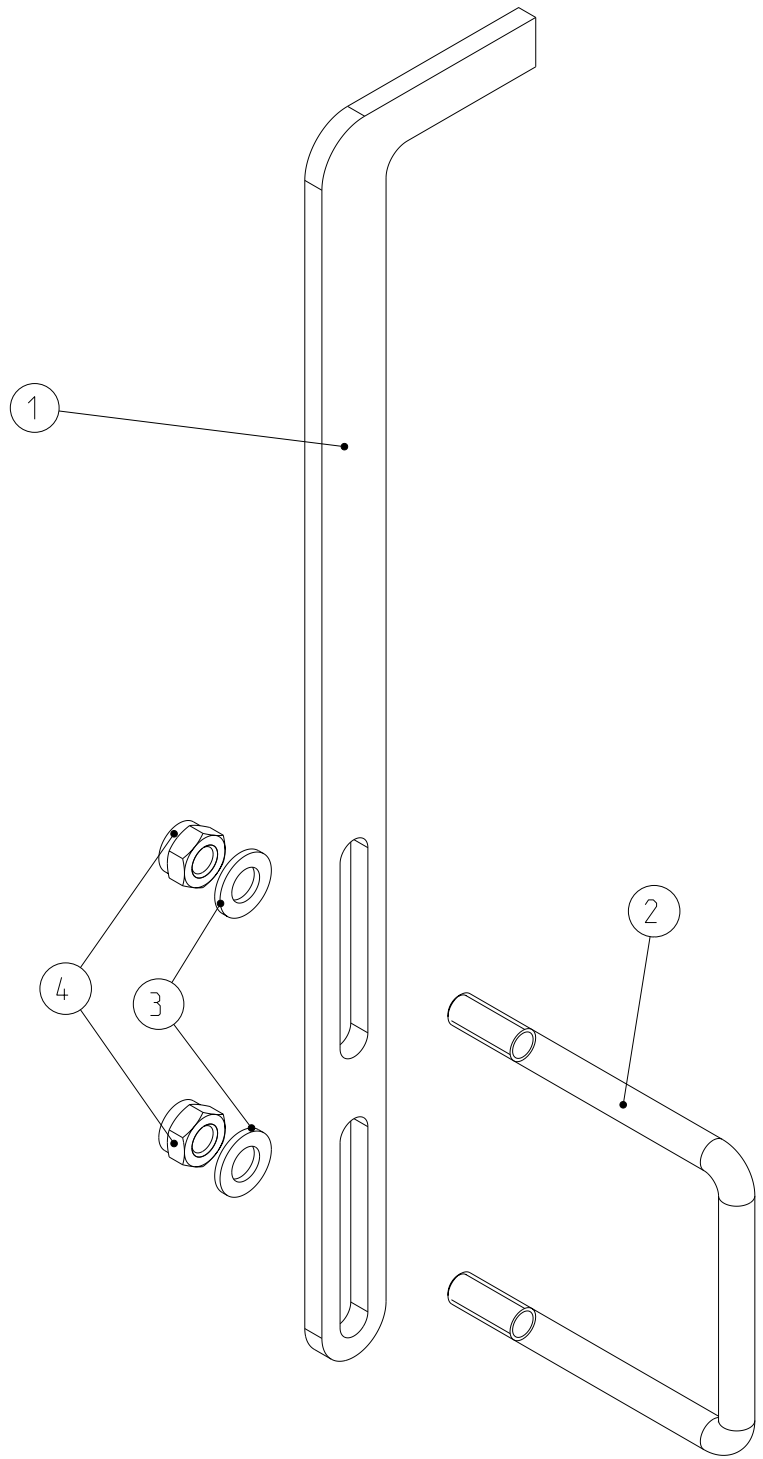



B4

Klappzylinder  
Folding cylinder  
Verin repliage

Zylinder/Cylinder/verin 90/45/405/730 (8172.04.02)

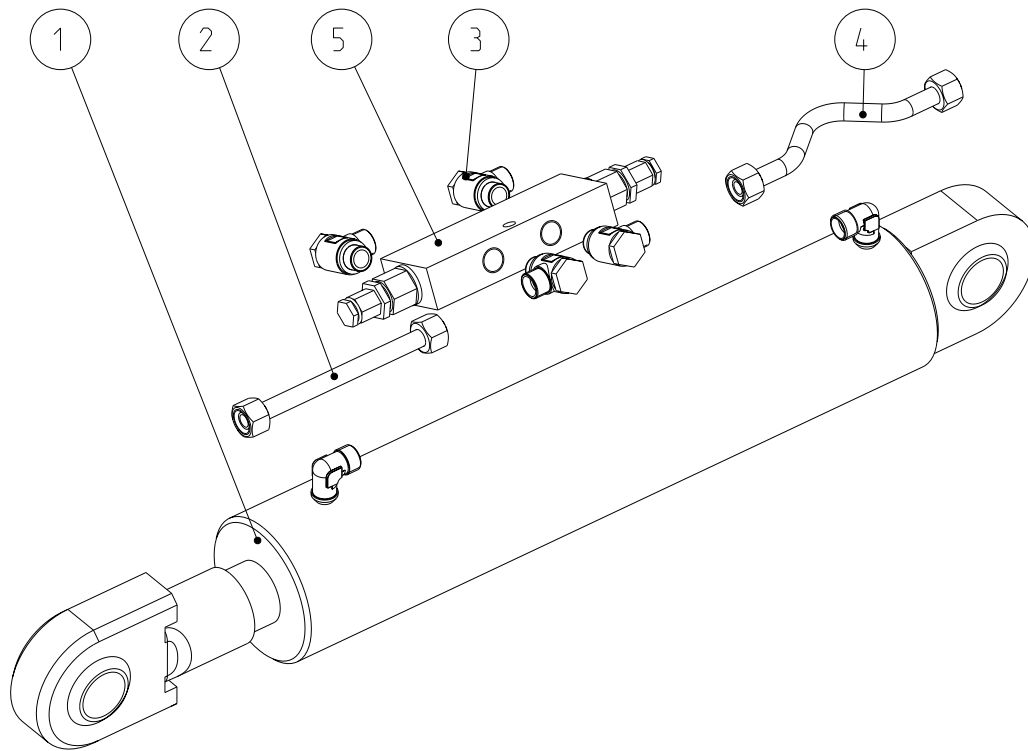



B5

Tiefenstellzylinder  
#  
#

Zylinder/Cylinder/Verin 80/35/110/360 (8172.04.11/12)

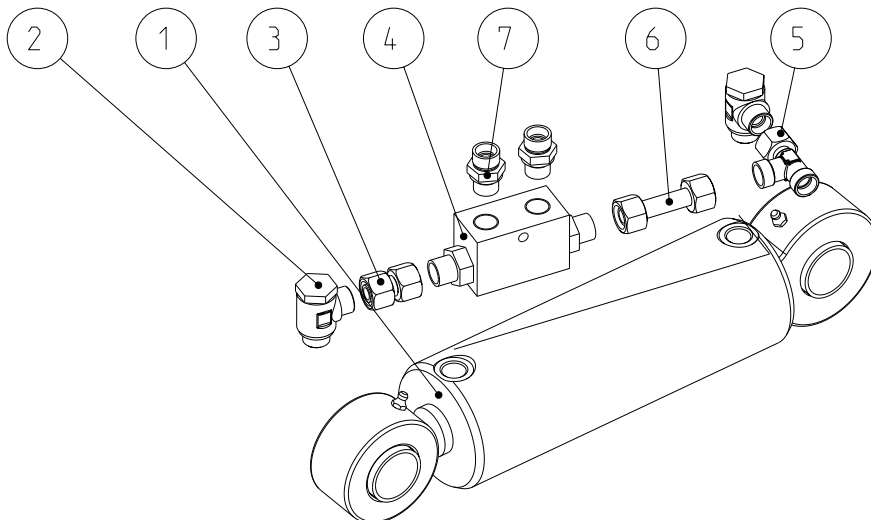
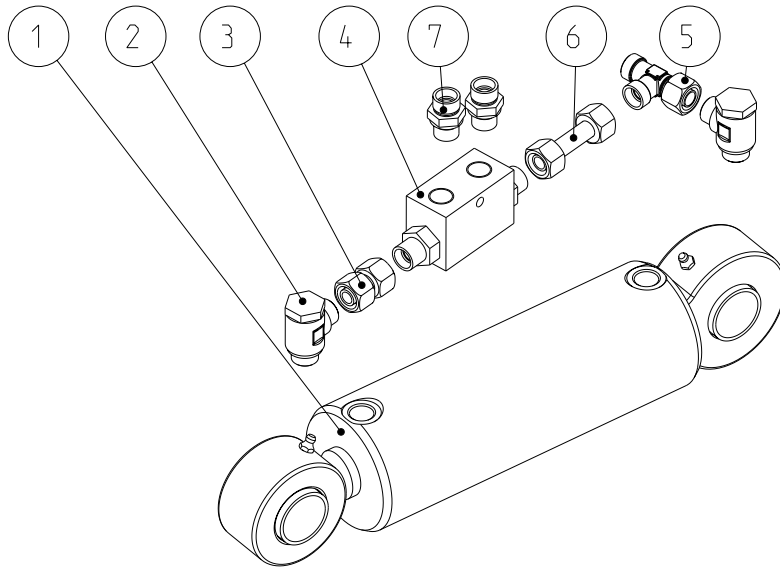



**B5**

Tiefenstellzylinder

#  
#

**Zylinder / Cylinder / Verin 80/35/110/360 (8172.04.11/12)**

Bild Ref. Fig.	Bestellnr. Part.-No. Référence	Stck Qty. Qte.	Bezeichnung	Technische Angaben Technical data Données techniques	Description	Désignation
1-7	8172.04.11	1	ZYLINDER, RECHTS KPL		CYLINDER R.H. CPL.	VERIN DROIT CPL.
1-7	8172.04.12	1	ZYLINDER, LINKS KPL.		CYLINDER L.H. CPL.	VERIN GAUCHE CPL.
.	.	.	.	.	.	.
1	8168.18.01	1	ZYLINDER KPL.	80/35/110/360		
2	9001.60.36	2	Schwenkverschraub.	DSVW-12 PS/1	Coupling	Raccord
3	4716.53.05	1	Hydraulikrohr kpl.	L=40 mm	Hydr.pipe cpl.	Tube cpl.
4	8154.24.02	1	Doppelrückschlagventil		Valve	Limiteur
5	4723.02.05	1	Einstellb. L-Anschlußst.	EVL-12 L	L-coupling	Raccord
6	8172.02.04	1	Hydraulikrohr kpl.	L=62 mm	Hydr.pipe cpl.	Tube cpl.
7	4723.02.03	2	Gerade Einschraubversch	GE12-L/R ED	Male stud coupling	Raccord
.	.	.	.	.	.	.
.	.	.	.	.	.	.
.	.	.	.	.	.	.
.	.	.	.	.	.	.
.	.	.	.	.	.	.
.	.	.	.	.	.	.
.	.	.	.	.	.	.
.	.	.	.	.	.	.
.	.	.	.	.	.	.
.	.	.	.	.	.	.
.	.	.	.	.	.	.
.	.	.	.	.	.	.
.	.	.	.	.	.	.
.	.	.	.	.	.	.
.	.	.	.	.	.	.
.	.	.	.	.	.	.
.	.	.	.	.	.	.
.	.	.	.	.	.	.
.	.	.	.	.	.	.
.	.	.	.	.	.	.
.	.	.	.	.	.	.
.	.	.	.	.	.	.
.	.	.	.	.	.	.

B6

Fahrwerkzylinder  
Wheel carrier cylinder  
Verin porte essieu

Zylinder/Cylinder/Verin 90/45/405/730 (8172.04.01)

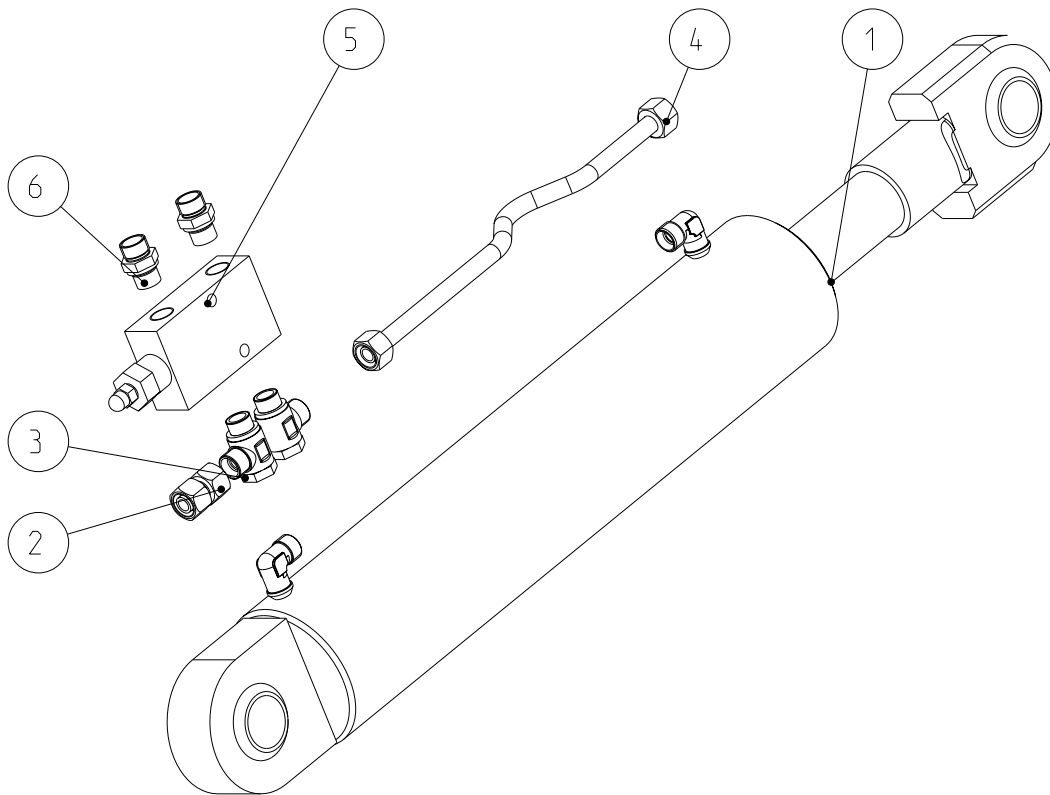



B7

Tiefenanzeige  
#  
#

MegaSeed ab/min./de 4,0m, Field Bird ab/min./de 4,5m

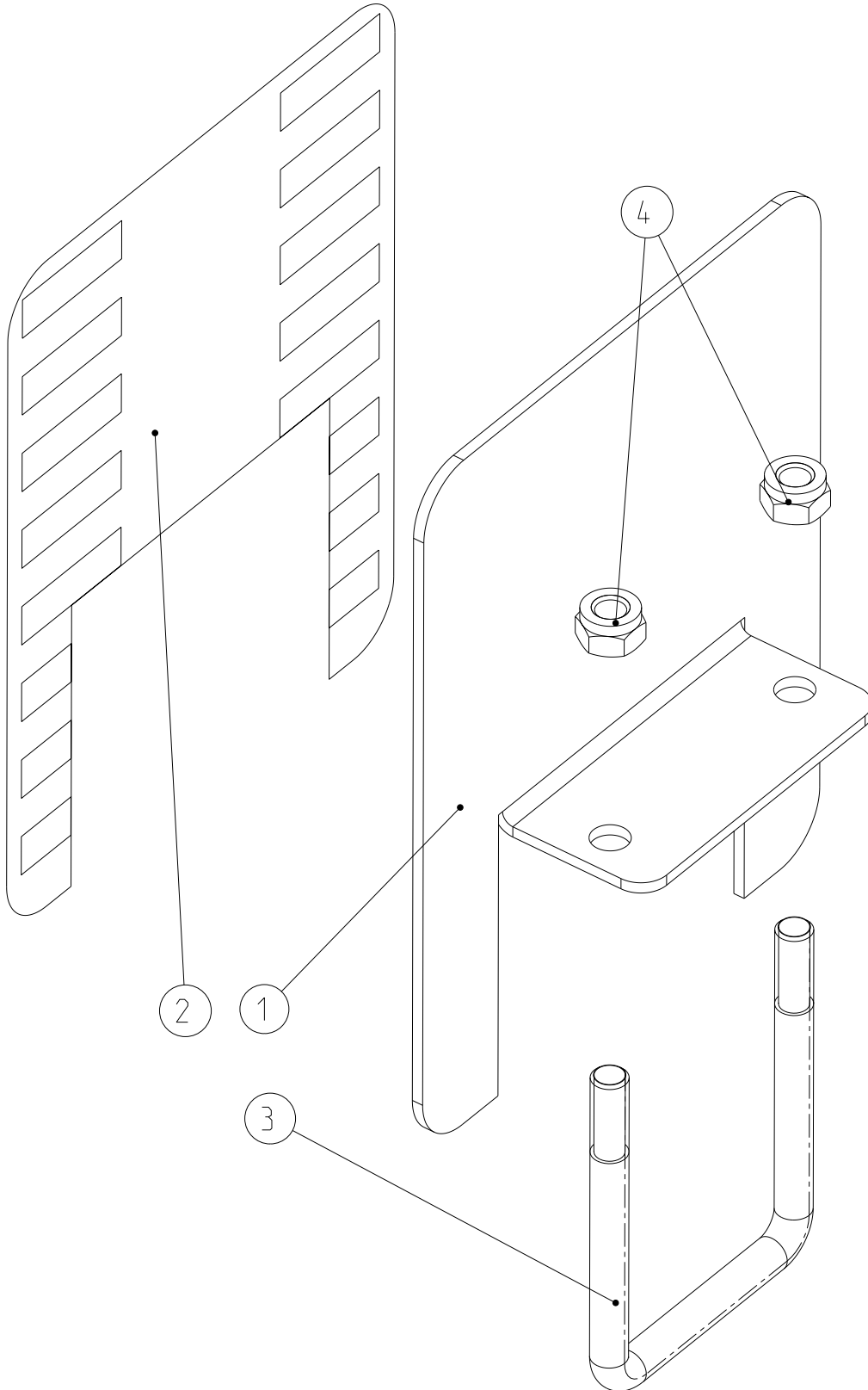



**B7**

Tiefenanzeige

#  
#

**MegaSeed ab/min./de 4,0m, Field Bird ab/min./de 4,5m**

Bild Ref. Fig.	Bestellnr. Part.-No. Référence	Stck Qty. Qte.	Bezeichnung	Technische Angaben Technical data Données techniques	Description	Désignation
1-4	6464.00.30	1	TIEFENANZEIGE MONT.			
	.					
1	6464.00.32	1	Winkel		Angle	Angle
2	9998.09.03	1	Aufkleber	"Tiefenskala Vorwerkze	Sticker	Autocollant
3	8406.33.02	1	Schraubband	MC-12X93X115	Cross section	Bride
4	985D12PA	2	Sechskantmutter	M12 DIN985-8 vz.	Hex. nut	Ecrou 6 pans
	.					
	.					
	.					
	.					
	.					
	.					
	.					
	.					
	.					
	.					
	.					
	.					
	.					
	.					
	.					
	.					
	.					
	.					
	.					
	.					
	.					
	.					
	.					
	.					
	.					
	.					
	.					
	.					
	.					
	.					
	.					

**B8**

Hydraulik f. Fahrwerk

Hydr.pipe for wheel car. **Field BIRD, MegaSeed bls/up to/á 4,5m**

HydrauliQue pour porte essieu

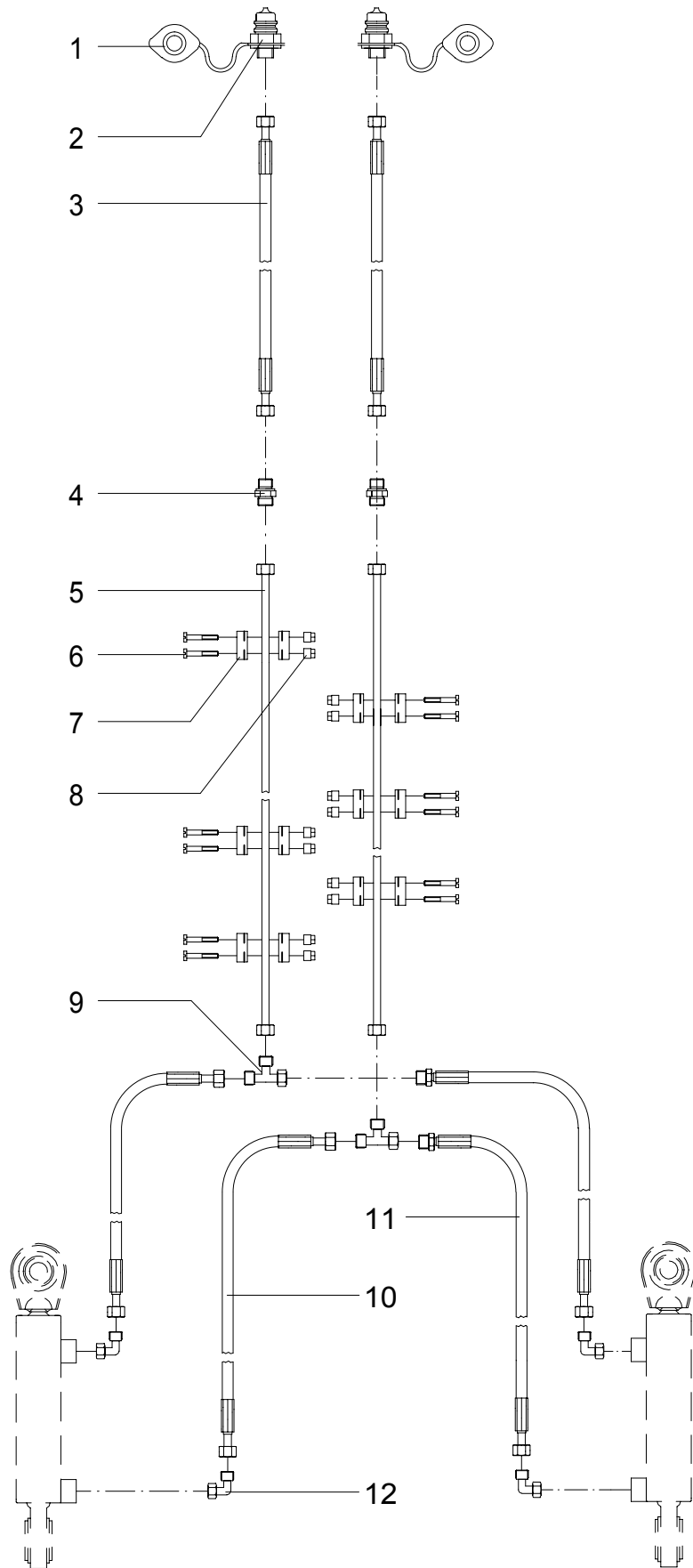

8173.03.10





Fahrwerk mit Bremsachse  
Wheel carrier with brake axle  
Porte essieu de frein

Field Bird, MegaSeed

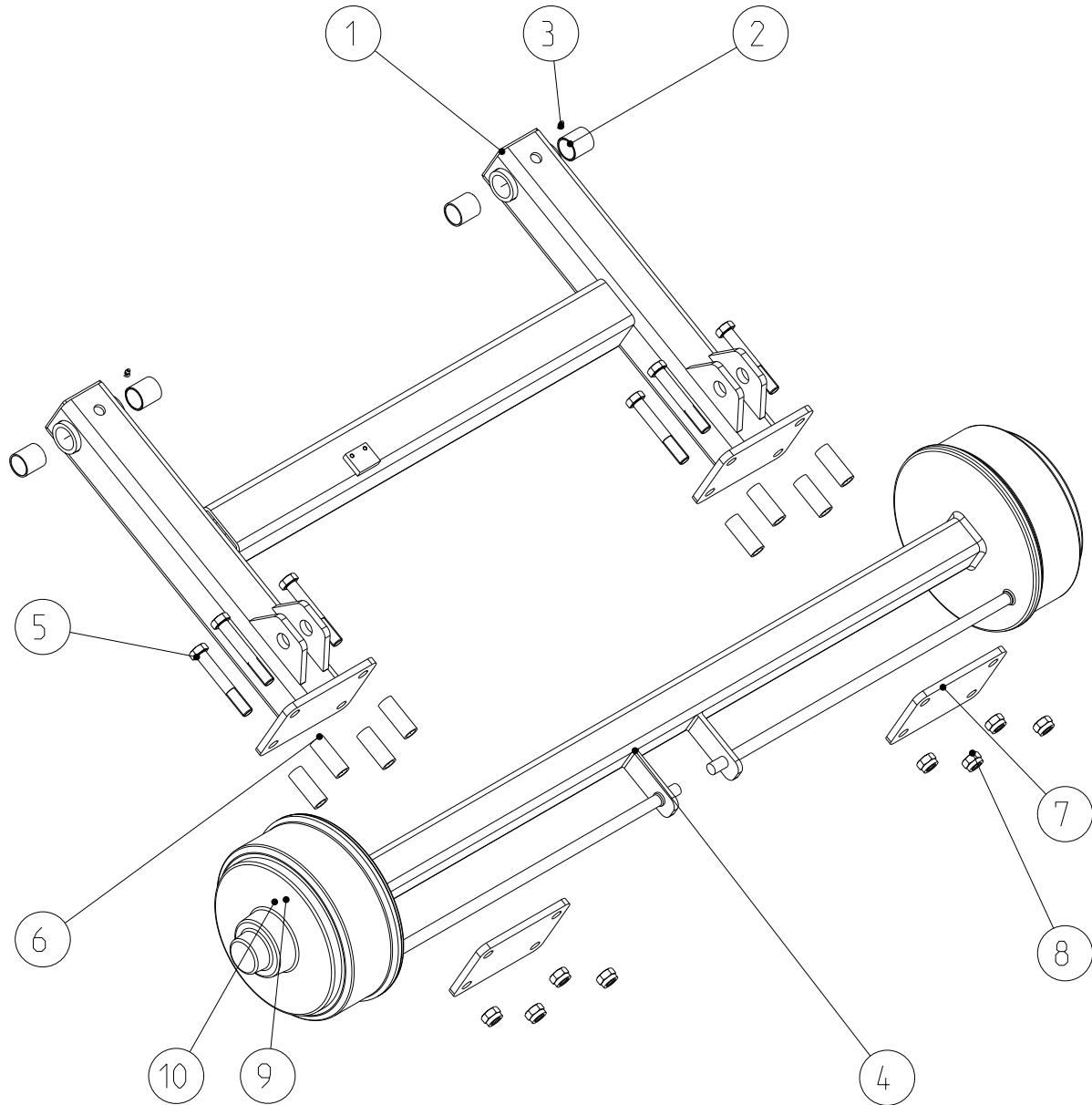



C1

Druckluftbremse  
Compress. air brake  
Freinage pneumatique

Mega Seed

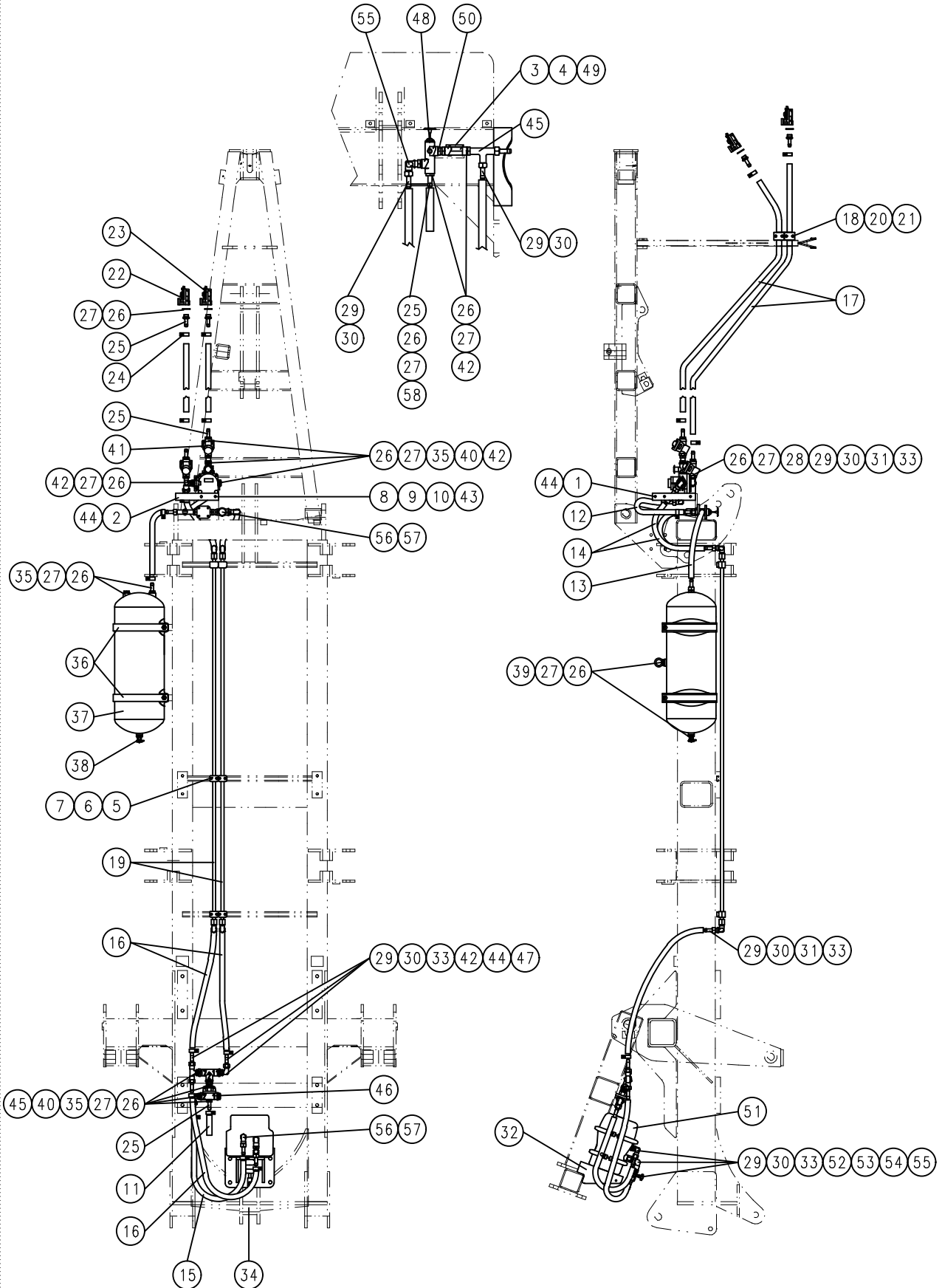

9032.05.01



**C1**

 Druckluftbremse  
 Compress. air brake  
 Freinage pneumatique

**Field Bird, MegaSeed**

Bild Ref. Fig.	Bestellnr. Part.-No. Référence	Stck Qty. Qte.	Bezeichnung	Technische Angaben Technical data Données techniques	Description	Désignation
1	933D825PA	4	Sechskantschraube	M8x25 DIN933-8.8 vz.	Hex. bolt	Vis 6 pans
2	9017.17.10	1	Winkel			
3	9018.28.09	1	Klemmplatte		Clamp plate	Plaque de serrage
4	931D855PA	4	Sechskantschraube	M8x55 DIN931-8.8 vz.	Hex. bolt	Vis 6 pans
5	4753.56.05	6	Schienenmutter		Nut	Ecrou
6	84D625W	6	Zylinderschraube	M6x25 DIN84-4.8	Spline screw	Vis cylindrique
7	4777.35.01	6	Rohrschelle		Pipe clamp	Collier
8	125DA8.4A	2	Scheibe	A8,4 DIN125 vz.	Washer	Rondelle
9	933D1050PA	2	Sechskantschraube	M10x50 DIN933-8.8 vz.	Hex. bolt	Vis 6 pans
10	980DV10PA	2	Sicherungsmutter	VM10 DIN980-8 vz.	Lock nut	Ecrou frein
11	6102.13.12	1	Bremsschlauch	13x6x100 mm	Hose	Conduite flexible
12	6102.13.13	1	Bremsschlauch	13x6x480 mm	Hose	Conduite flexible
13	6102.13.14	1	Bremsschlauch	13x6x580 mm	Hose	Conduite flexible
14	6102.13.15	2	Bremsschlauch	13x6x620 mm	Hose	Conduite flexible
15	6102.13.16	1	Bremsschlauch	13x6x730 mm	Hose	Conduite flexible
16	6102.13.17	3	Bremsschlauch	13x6x920 mm	Hose	Conduite flexible
17	6102.13.18	2	Bremsschlauch	13x6x3150 mm	Hose	Conduite flexible
18	8132.11.01	2	Rohrschelle		Pipe clamp	Collier
19	HR1515X1805	2	Rohr	L=1805 mm	Pipe	Tube
20	84D650WA	4	Zylinderschraube	M6x50 DIN84-4.8 vz.	Spline screw	Vis cylindrique
21	985D6PA	4	Sechskantmutter	M6 DIN985-8 vz.	Hex. nut	Ecrou 6 pans
22	6102.01.02	1	Kupplungskopf, gelb		Coupling yellow	Raccord jaune
23	6102.01.01	1	Kupplungskopf, rot		Coupling red	Raccord rouge
24	6102.12.01	22	Schlauchschelle		Hose clip	Collier
25	6102.10.01	6	Schlauchstutzen		Coupling	Raccord
26	6102.07.01	24	Messingdichtring	M22x1,5	Seal ring	Joint
27	6102.07.02	23	Gummidichtring	M22x1,5	Seal ring	Joint
28	6102.03.01	2	Leerkupplung		Coupling	Coupleur
29	6102.10.02	15	Steckhülse			
30	6102.04.04	15	Überwurfmutter	M22x1,5		
31	6102.11.01	5	Winkelverschraubung	M22x1,5	Elbow coupling	Raccord
32	6102.30.02	1	Bremskonsole		Spacer	Console
33	6102.07.03	15	Dichtring			
34	6102.26.01	1	Gabelgelenk			
35	6102.06.02	3	Verschlußschraube		Hexagon head plug	Bouchon fileté
36	6102.02.11	2	Befestigungskonsole		Spacer	Console
37	6102.02.10	1	Luftbehälter			
38	6102.04.01	1	Hohlschraube m.Prüf.		Bolt	Vis

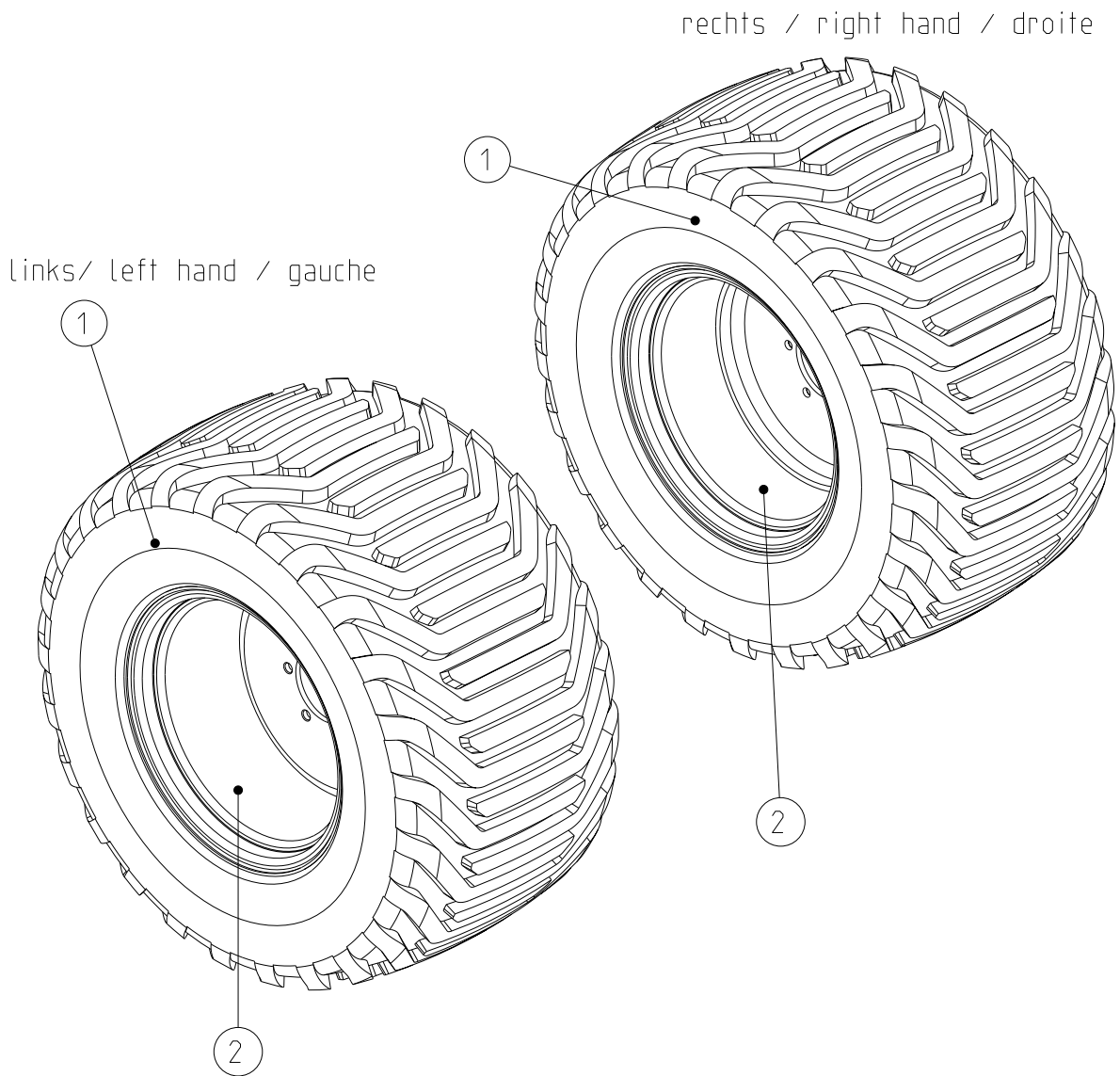





**D**

Zahnpackerwalzen GZW  
 Packer roller GZW  
 Rouleaux packer GZW

**MegaSeed 3001**

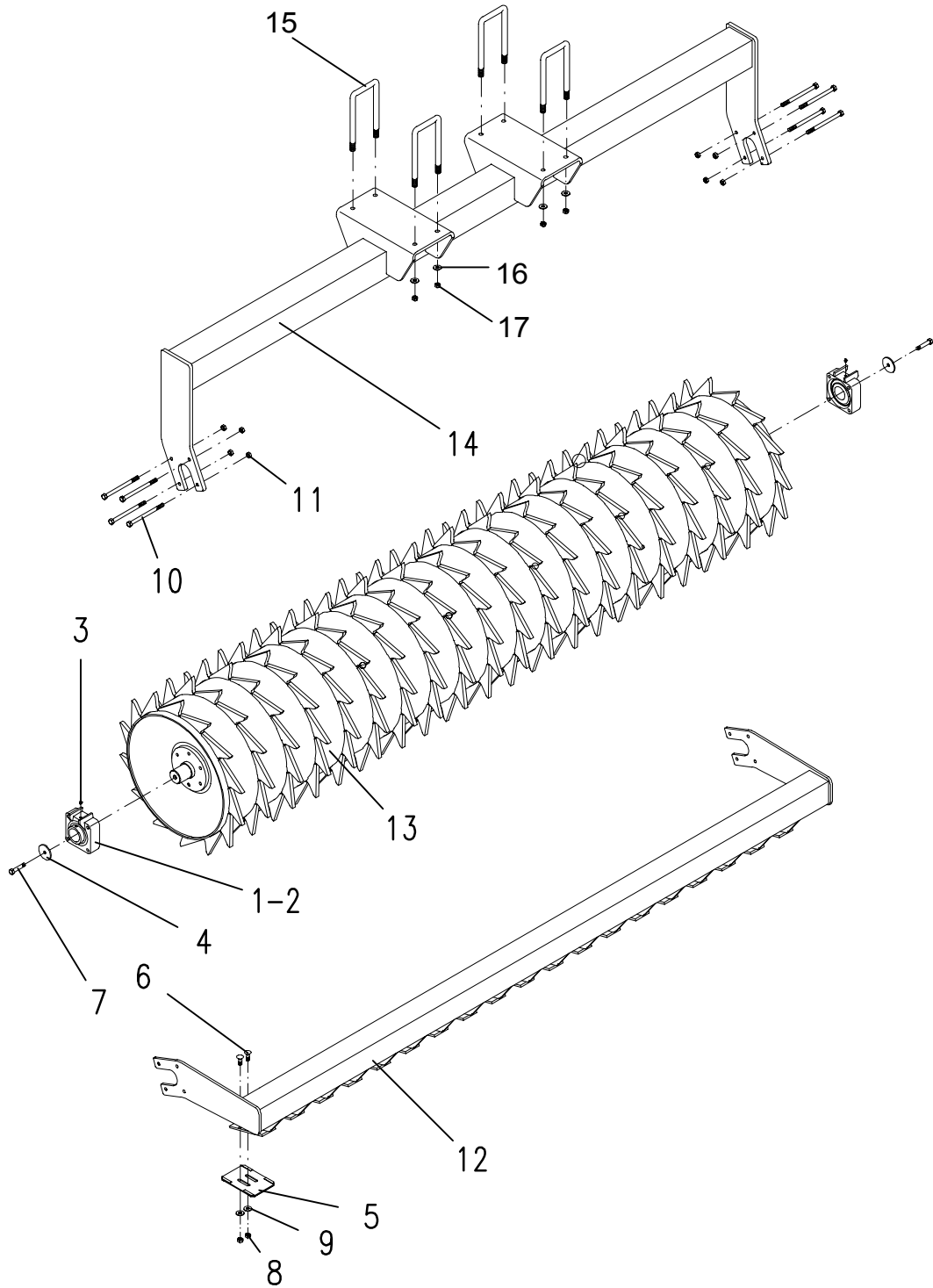



**D1**

Zahnpackerwalzen GZW  
 Packer roller GZW  
 Rouleaux packer GZW

**Field Bird, Mega Seed 4001 K2, 4501 K2**

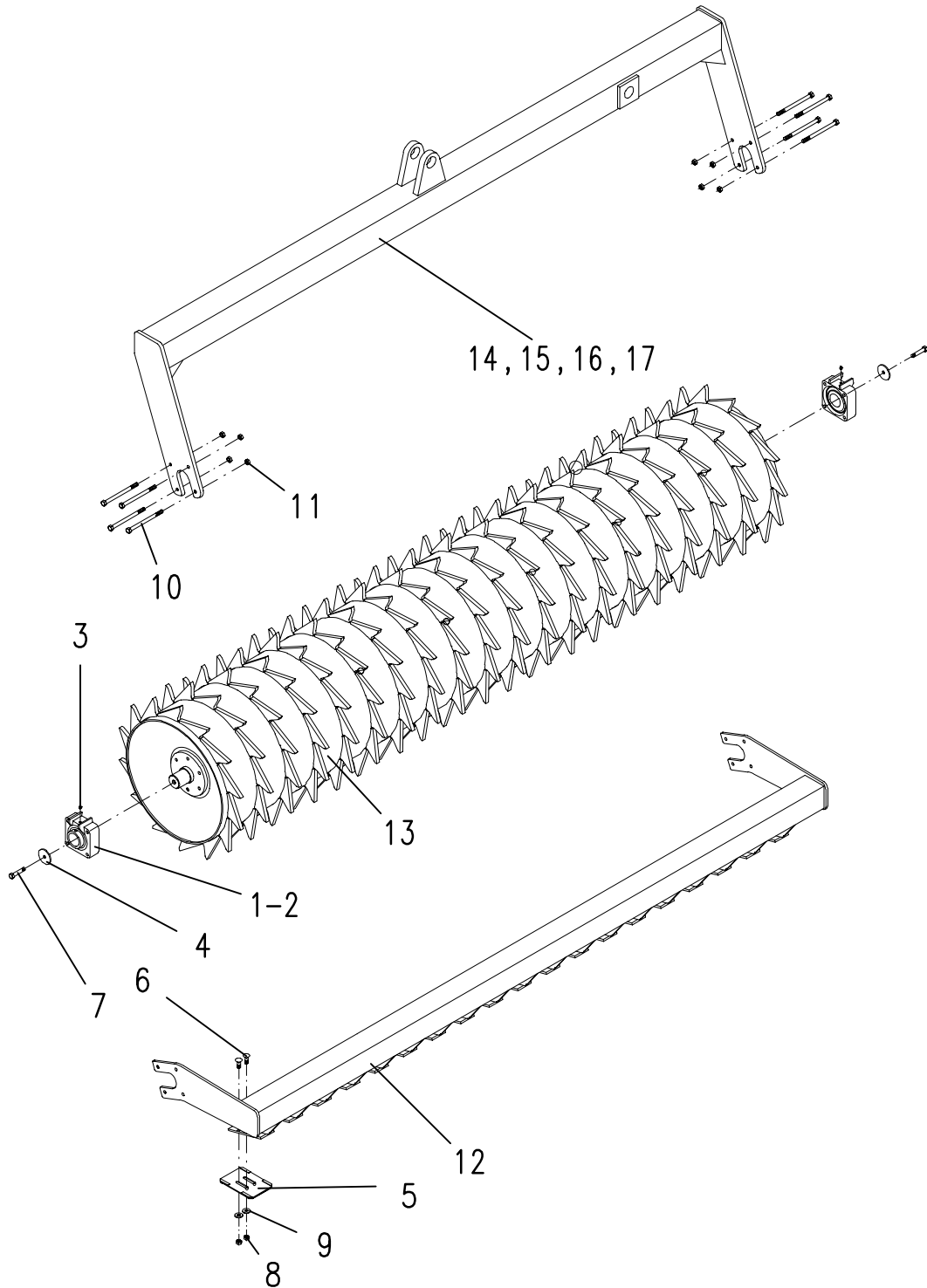

6810.18.10  
 6810.18.11



**D1**

Zahnpackerwalze GZW  
Packer roller GZW  
Rouleau packer GZW

**Field Bird, MegaSeed ab /min./de 4,0 m**

Bild Ref. Fig.	Bestellnr. Part.-No. Référence	Stck Qty. Qte.	Bezeichnung	Technische Angaben Technical data Données techniques	Description	Désignation
1-3	8434.29.01	4	FLANSCHLAGER KPL.	Di= Ø55 mm	BEARING CPL.	PALIER CPL.
1	8434.29.03	1	Spannlager	PDNF 160-55-26	Bearing	Roulement
2	8434.29.02	1	Flanschlager		Bearing	Palier
3	71412DB81	1	Schmiernippel	BM8x1 DIN71412	Grease nipple	Graisseur
	Spezialfett	0,004 kg	Spezialfett		Grease	Graisse
4	8434.29.09	4	Scheibe		Washer	Rondelle
5	8406.00.10	24	Abstreiferblech, hartbeschicht.	GZW 660	Scrapers plate hard coated	Tôle de décrotoir dur
6	603D1230PA	48	Flachrundschrabe	M12x30 DIN603-8.8 vz.	Bolt	Vis
7	933D1235N	8	Sechskantschrabe	M12x35 DIN933-10.9	Hex.bolt	Vis 6 pans
8	934D12PA	48	Sechskantmutter	M12 DIN934-8 vz.	Hex.nut	Ecrou 6 pans
9	7349D13A	48	Scheibe	13 DIN7349 vz.	Washer	Rondelle
10	931D1290N	16	Sechskantschrabe	M12x90 DIN931-10.9	Hex.bolt	Vis 6 pans
11	980DV12NA	16	Sicherungsmutter	VM12 DIN980-10 vz.	Lock nut	Ecrou frein
12	6810.11.05	2	Abstreiferbalken kurz	4,0m	Scrapers beam short	Barre de décrotoir court
12	6810.11.03	2	Abstreiferbalken	4,5m	Scrapers beam	Barre de décrotoir
13	6810.07.09	2	Zahnpackerwalze kurz	GZW 660 / 4,0m	Packer roller short	Rouleau packer court
13	6810.07.08	2	Zahnpackerwalze	GZW 660 / 4,5m	Packer roller	Rouleau packer
14	9032.06.02	1	Tragrahmen, links	4,0 m	Beam l.h.	Bâti gauche
15	9032.06.01	1	Tragrahmen, rechts	4,0 m	Beam r.h.	Bâti droit
16	9032.06.04	1	Tragrahmen, links	4,5 m	Beam l.h.	Bâti gauche
17	9032.06.03	1	Tragrahmen, rechts	4,5 m	Beam r.h.	Bâti droit

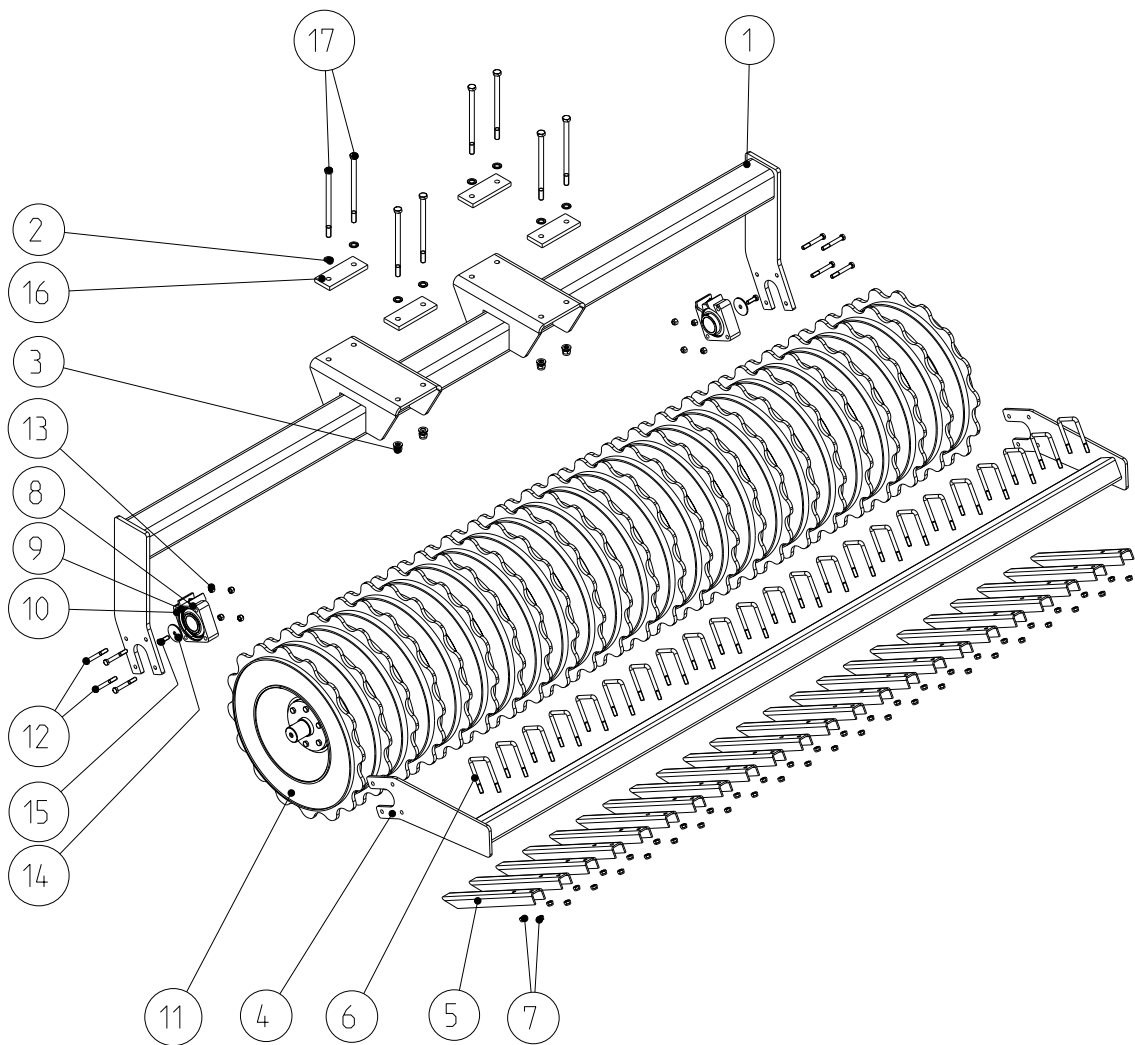

**D2**

Mulchpackerwalze MPW 640  
 Mulchpacker roller MPW 640  
 Rouleau mulchpacker MPW 640

**MegaSeed 3001 S**

Bild Ref. Fig.	Bestellnr. Part.-No. Référence	Stck Qty. Qte.	Bezeichnung	Technische Angaben Technical data Données techniques	Description	Désignation
1	9031.01.25	1	Rahmen	3,0m	Frame	Bâti
2	6916D17A	16	Scheibe	17 DIN6916 vz.	Washer	Rondelle
3	985D16PA	8	Sechskantmutter	M16 DIN985-8 vz.	Hex. nut	Ecrou 6 pans
4-7	6813.04.01	1	ABSTREIFER	MPW 640 / 3,0m	SCRAPER	BARRE DECROTTOIR
4	6813.08.01	1	Abstreifer	MPW 640 / 3,0m	Scraper	Barre décrotoir
5	6813.04.10	23	Abstreiferblech		Scraper plate	Tôle de décrotoir
6	8406.33.02	23	Schraubband	MC-12X93X115	Cross section	Bride
7	985D12PA	46	Sechskantmutter	M12 DIN985-8 vz.	Hex. nut	Ecrou 6 pans
8-10	8434.29.01	2	FLANSCHLAGER KPL.	Di= Ø55 mm	BEARING CPL.	PALIER CPL.
8	8434.29.03	2	Spannlager	PDNF 160-55-26	Bearing	Roulement
9	8434.29.02	2	Flanschlager		Bearing	Palier
10	71412DB81	2	Schmiernippel	BM8x1 DIN71412	Grease nippel	Graisseur
	Spezialfett	0,002 kg	Spezialfett		Grease	Graisse
11	6813.01.01	1	Mulchpackerwalze	MPW 640 / 3,0m	Mulchpacker roller	Rouleau mulchpacker
12	931D1290PA	8	Sechskantschraube	M12x90 DIN931-8.8 vz.	Hex. bolt	Vis 6 pans
13	980DV12PA	8	Sicherungsmutter	VM12 DIN980-8 vz.	Lock nut	Ecrou frein
14	8434.29.09	2	Scheibe		Washer	Rondelle
15	933D1235PA	2	Sechskantschraube	M12x35 DIN933-8.8 vz.	Hex. bolt	Vis 6 pans
16	9031.01.26	4	Lasche		Latch	Plat
17	931D16260PA	8	Sechskantschraube	M16x260 DIN931-8.8 vz.	Hex.bolt	Vis 6 pans
.	.	.	.	.	.	.
.	.	.	.	.	.	.
.	.	.	.	.	.	.
.	.	.	.	.	.	.
.	.	.	.	.	.	.
.	.	.	.	.	.	.
.	.	.	.	.	.	.
.	.	.	.	.	.	.
.	.	.	.	.	.	.
.	.	.	.	.	.	.
.	.	.	.	.	.	.
.	.	.	.	.	.	.
.	.	.	.	.	.	.
.	.	.	.	.	.	.
.	.	.	.	.	.	.
.	.	.	.	.	.	.
.	.	.	.	.	.	.
.	.	.	.	.	.	.

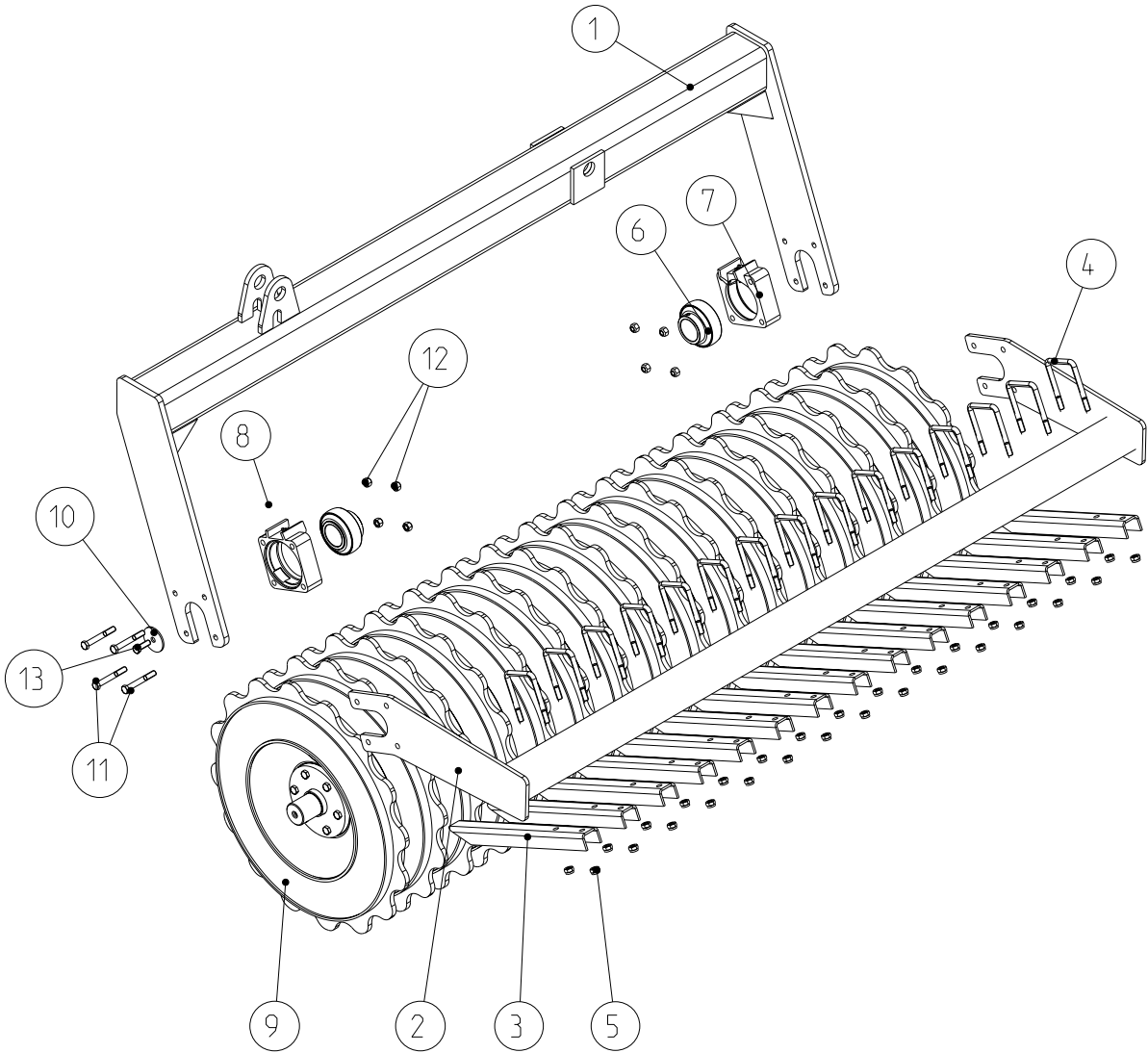



**D3**

Mulchpackerwalze MPW 640  
 Mulchpacker roller MPW 640  
 Rouleau mulchpacker MPW 640

**Field Bird, MegaSeed ab/min./de 4,0 m**

Bild Ref. Fig.	Bestellnr. Part.-No. Référence	Stck Qty. Qte.	Bezeichnung	Technische Angaben Technical data Données techniques	Description	Désignation
1-13	6464.03.08	1	MULCHPACK.-WALZE, LINKS	MPW 640 / 4,0 m	MULCHPACKER ROLLER	ROULEAU MULCHPACKER
1-13	6464.03.09	1	MULCHPACK.-WALZE, RECHTS	MPW 640 / 4,0 m	MULCHPACKER ROLLER	ROULEAU MULCHPACKER
1-13	6464.03.10	1	MULCHPACK.-WALZE, LINKS	MPW 640 / 4,5 m	MULCHPACKER ROLLER	ROULEAU MULCHPACKER
1-13	6464.03.11	1	MULCHPACK.-WALZE, RECHTS	MPW 640 / 4,5 m	MULCHPACKER ROLLER	ROULEAU MULCHPACKER
.	.	.	.	.	.	.
1	9032.06.02	1	Tragrahmen, links	4,0 m	Beam l.h.	Bâti gauche
1	9032.06.01	1	Tragrahmen, rechts	4,0 m	Beam r.h.	Bâti droit
1	9032.06.04	1	Tragrahmen, links	4,5 m	Beam l.h.	Bâti gauche
1	9032.06.03	1	Tragrahmen, rechts	4,5 m	Beam r.h.	Bâti droit
.	.	.	.	.	.	.
2-5	6813.04.07	1	ABSTREIFER, LINKS	4,0 m	SCRAPER L.H.	BARRE DECROTTOIR GAU
2-5	6813.04.08	1	ABSTREIFER, RECHTS	4,0 m	SCRAPER R.H.	BARRE DECROTTOIR DROI
2-5	6813.04.05	1	ABSTREIFER, LINKS	4,0 m	SCRAPER L.H.	BARRE DECROTTOIR GAU
2-5	6813.04.06	1	ABSTREIFER, RECHTS	4,0 m	SCRAPER R.H.	BARRE DECROTTOIR DROI
2	6813.08.04	2	Abstreifer	4,0 m	Scraper	Barre décrottoir
2	6813.08.05	2	Abstreifer	4,5 m	Scraper	Barre décrottoir
3	6813.04.10	30,34	Abstreiferblech		Scraper plate	Tôle de décrottoir
4	8406.33.02	30,34	Schraubband	MC-12X93X115	Cross section	Bride
5	985D12PA	60,68	Sechskantmutter	M12 DIN985-8 vz.	Hex. nut	Ecrou 6 pans
.	.	.	.	.	.	.
6-8	8434.29.01	4	FLANSCHLAGER KPL.	Di= Ø55 mm	BEARING CPL.	PALIER CPL.
6	8434.29.03	4	Spannlager	PDNF 160-55-26	Bearing	Roulement
7	8434.29.02	4	Flanschlager		Bearing	Palier
8	71412DB81	4	Schmiernippel	BM8x1 DIN71412	Grease nippel	Graisser
.	Spezialfett	0,002 kg	Spezialfett		Grease	Graisse
.	.	.	.	.	.	.
9	6813.01.04	2	Mulchpackerwalze	MPW 640 / 4,0m	Mulchpacker roller	Rouleau mulchpacker
9	6813.01.05	2	Mulchpackerwalze	MPW 640 / 4,5m	Mulchpacker roller	Rouleau mulchpacker
10	8434.29.09	4	Scheibe		Washer	Rondelle
11	931D1290N	16	Sechskantschraube	M12x90 DIN931-10.9	Hex.bolt	Vis 6 pans
12	980DV12PA	16	Sicherungsmutter	VM12 DIN980-8 vz.	Lock nut	Ecrou frein
13	933D1235PA	4	Sechskantschraube	M12x35 DIN933-8.8 vz.	Hex. bolt	Vis 6 pans
.	.	.	.	.	.	.
.	.	.	.	.	.	.
.	.	.	.	.	.	.
.	.	.	.	.	.	.
.	.	.	.	.	.	.
.	.	.	.	.	.	.

D6

Abstreiferübersicht

View of scrapers

MPW 640

Vue d'ensemble des décroisseurs

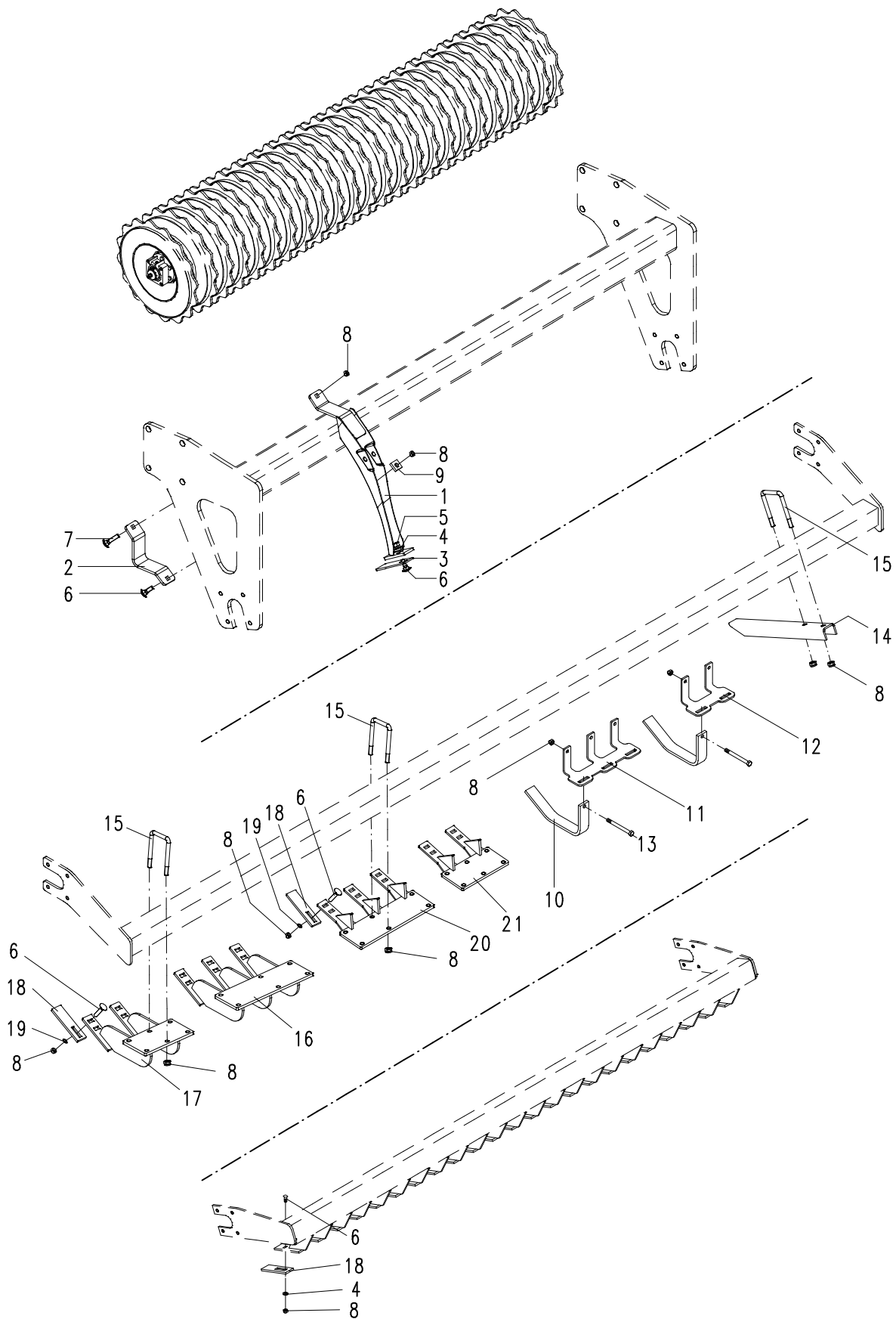

**D6**

Abstreiferübersicht  
View of scrapers  
Vue d'ensemble des décrottoirs

**MPW 640**

Bild Ref. Fig.	Bestellnr. Part.-No. Référence	Bezeichnung	Technische Angaben Technical data Données techniques	Description	Désignation
1	6813.28.01	Abstreifer		Scaper	Décrottoir
2	6813.27.11	Lagerblech		Plate	Tôle
3	6813.27.12	Abstreiferblech hartbesch.		Scraper plate hard coate	Tôle de décrottoir dur
4	6916D13A	Scheibe	13 DIN 6916 vz.	Washer	Rondelle
5	934D12P	Sechskantmutter	M12 DIN 934-8	Hex. nut	Ecrou 6 pans
6	603D1230PA	Flachrundschaube	M12x30 DIN603-8.8 vz.	Bolt	Vis
7	603D1250PA	Flachrundschaube	M12x50 DIN603-8.8 vz.	Bolt	Vis
8	985D12PA	Sechskantmutter	M12 DIN985-8 vz.	Hex.nut	Ecrou 6 pans
9	6813.27.15	Unterlegscheibe		Washer	Rondelle
.					
10	6813.04.20	Abstreiferblech		Scraper plate	Tôle de décrottoir
11	6813.04.23	Abstreifer-Klammer		Clasp	Crampon
12	6813.04.22	Abstreifer-Klammer		Clasp	Crampon
13	931D12120PA	Sechskantschraube	M12x120 DIN931-8.8 vz.	Hex. bolt	Vis 6 pans
.					
14	6813.04.10	Abstreiferblech	MPW 640	Scraper plate	Tôle de décrottoir
15	8406.33.02	Schraubband	MC-12X93X115	Cross section	Bride
.					
16	6813.33.02	Abstreiferhalter	3er	Scraper bracket	Support decrottoir
17	6813.33.01	Abstreiferhalter	2er	Scraper bracket	Support de decrottoir
18	6813.26.33	Abstreiferblech		Scraper plate	Tôle de décrottoir
19	7349D13A	Scheibe	13 DIN7349 vz.	Washer	Rondelle
.					
20	6813.33.06	Abstreiferhalter	3er	Scraper bracket	Support decrottoir
21	6813.33.05	Abstreiferhalter	2er	Scraper bracket	Support decrottoir
.					
.					
.					
.					
.					
.					
.					
.					
.					
.					

**D7**

Abstreiferübersicht

View of scrapers

**RIPA 580, RIPA-M 600**

Vue d'ensemble des décroisseurs

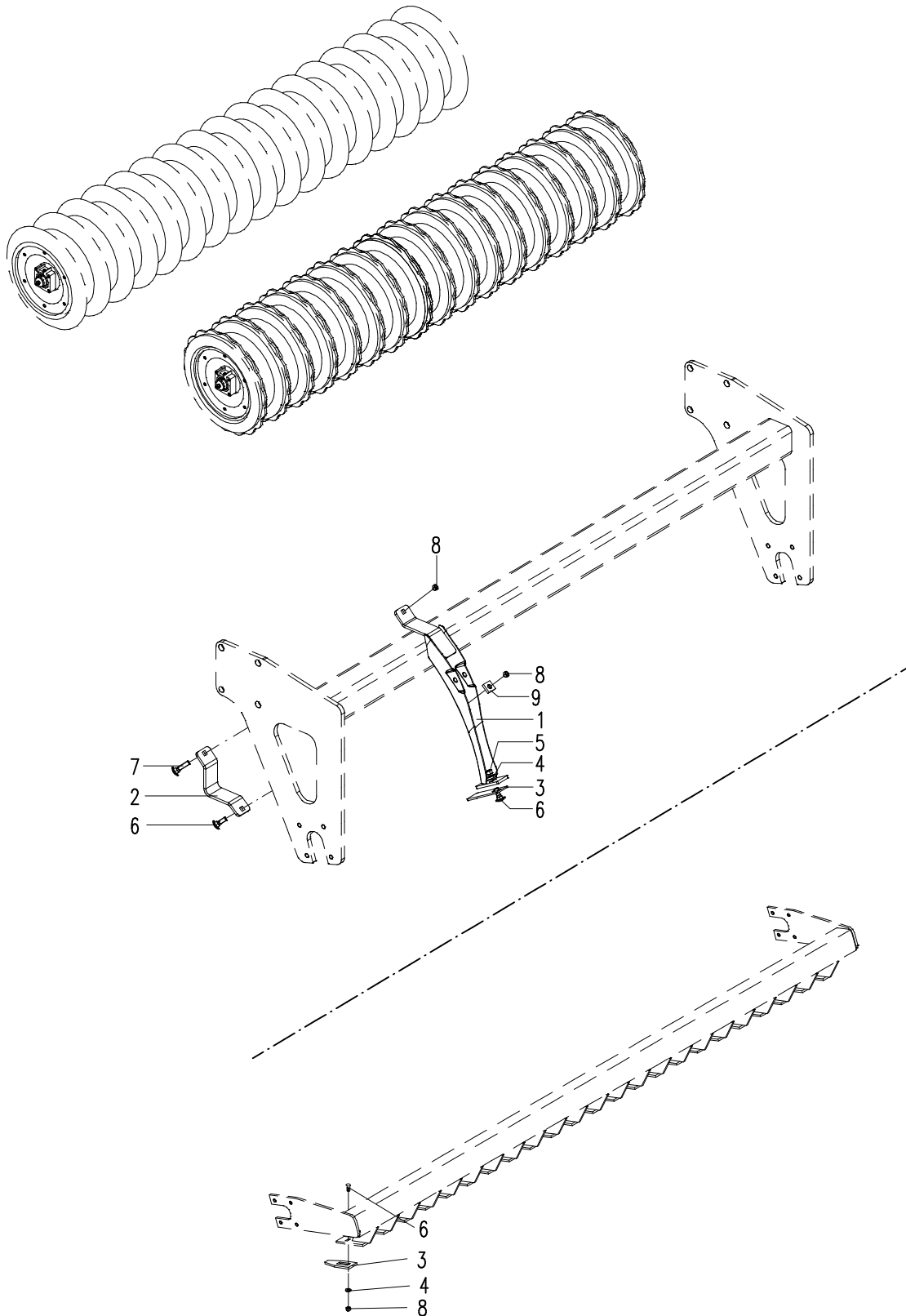



E

Mulchscheibensatz  
Set of Mulch-Discs  
Disques mulcheur

Mega Seed 3001 S Br.2/Serle 2

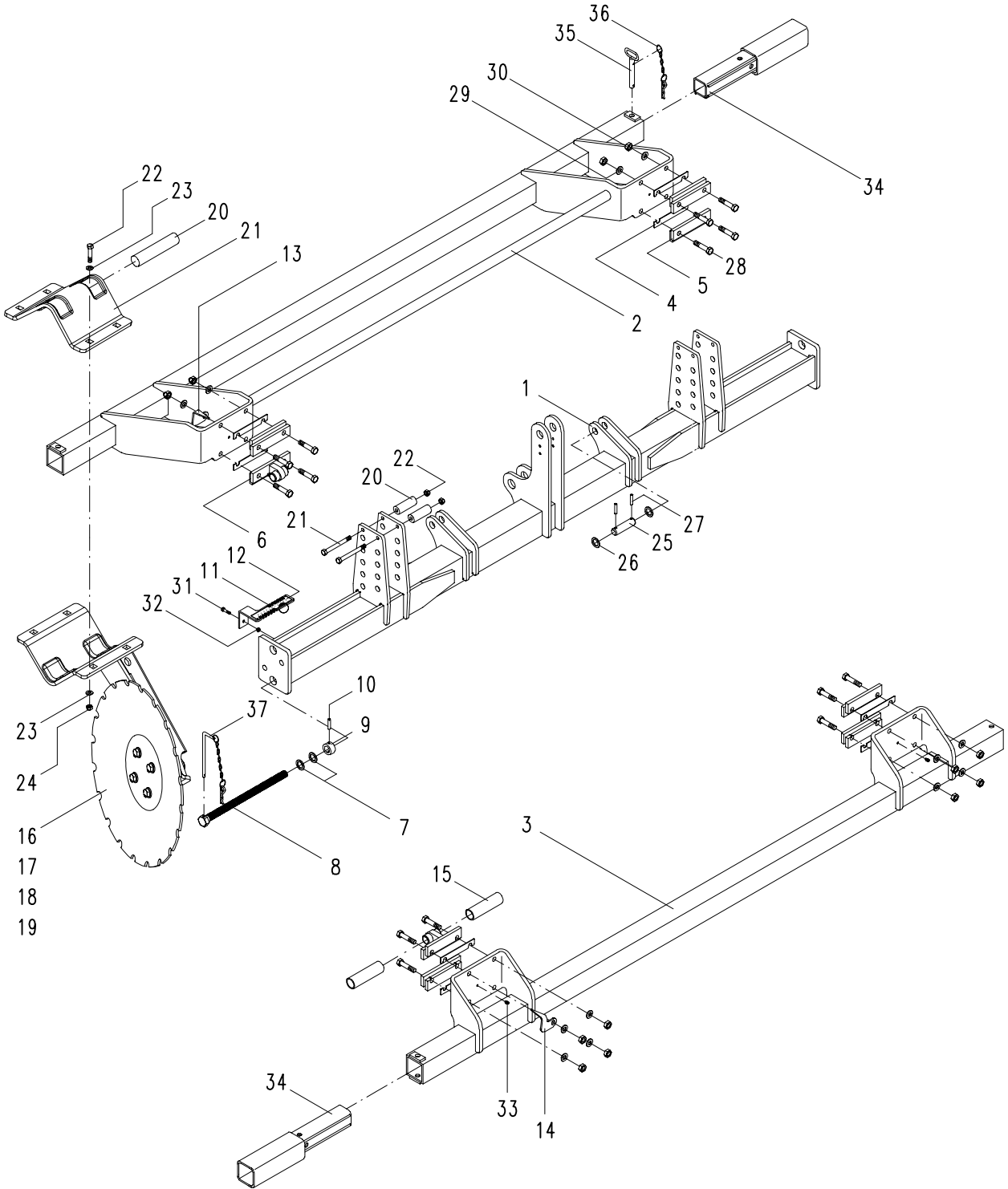

6464.37.01



**E**

Mulchscheibensatz  
Set of Mulch-Discs  
Disques mulcheur

**MegaSeed 3001 S Br.2 / Serie 2**

Bild Ref. Fig.	Bestellnr. Part.-No. Référence	Stck Qty. Qte.	Bezeichnung	Technische Angaben Technical data Données techniques	Description	Désignation
1	6464.37.17	1	Mittelrahmen		Central frame	Bâti central
2	6464.17.02	1	Rahmen, vorn		Front frame	Bâti avant
3	6464.18.02	1	Rahmen, hinten		Rear frame	Bâti arrière
4	6464.37.42	8	Distanzblech		Plate	Tôle
5	6464.26.40	6	Verstellhalter		Adjuster	Piece de réglage
6	6464.37.41	2	Verstellung		Adjuster	Reglage
7	6436.30.05	4	Dichtscheibe	DW-9	Sealing washer	Joint
8	6464.26.60	2	Spindel	L=540 mm	Spindle	Manivelle
9	6464.26.48	2	Hülse		Sleeve	Douille
10	1481D840A	2	Spannstift	8x40 DIN1481 vz.	Dowel pin	Goupille serrage
11	6464.37.66	1	Verstellskala kpl.		Scale	Echelle graduée
12	9998.03.55	1	Aufkleber	"Verstellskala"	Sticker	Autocollant
13	6464.37.69	1	Verstellanzeiger, vorn		Front adjust.indicator	Jauge de réglage avant
14	6464.37.68	1	Verstellanzeiger, hinten		Rear adjust.indicator	Jauge de réglage arrière
15	6464.26.55	4	Säschlauchstück		Hose piece	Pièce de conduite
16	9031.13.01	9	MULCHSCHEIB.-EINH. VORN		FRONT DISC UNIT	DISQUE AVANT CPL.
17	9031.13.02	9	MULCHSCHEIB.-EINH. HINTEN		REAR DISC UNIT	DISQUE ARRIERE CPL.
18	9031.13.07	2	RAND-MULCHSCH.-EINH. VORN		FRONT BORDER DISC	DISQUE BORD. AVANT CPL.
19	9031.13.06	2	RAND-MULCHSCH.-EINH. HINT.		REAR BORDER DISC	DISQUE BORD. ARRIERE
20	9031.01.19	88	Gummi-Element		Rubber element	Elément silent
21	9031.01.10	22	Lagerblech		Plate	Tôle
22	933D1260PA	88	Sechskantschraube	M12x60 DIN933-8.8 vz.	Hex. bolt	Vis 6 pans
23	6916D13A	176	Scheibe	13 DIN 6916 vz.	Washer	Rondelle
24	985D12PA	88	Sechskantmutter	M12 DIN985-8 vz.	Hex. nut	Ecrou 6 pans
25	1000.05.03	2	Bolzen		Pin	Axe
26	126D26A	4	Scheibe	26 DIN126 vz.	Washer	Rondelle
27	1481D845A	4	Spannstift	8x45 DIN1481 vz.	Dowel pin	Goupille serrage
28	931D1670NA	16	Sechskantschraube	M16x70 DIN931-10.9 vz.	Hex. bolt	Vis 6 pans
29	7349D17A	16	Scheibe	17 DIN7349 vz.	Washer	Rondelle
30	980DV16PA	16	Sicherungsmutter	VM16 DIN980-8 vz.	Lock nut	Ecrou frein
31	933D830PA	1	Sechskantschraube	M8x30 DIN933-8.8 vz.	Hex. bolt	Vis 6 pans
32	980DV8PA	1	Sicherungsmutter	VM8 DIN980-8 vz.	Lock nut	Ecrou frein
33	4716.38.00	6	Schmiernippel	H1 8x1 KX-1	Grease nipple	Graisser
34	6464.19.01	2	Seitenverlängerung		Extension	Rallonge
35	6248.14.00	2	Steckbolzen	Ø16 mm	Pin	Axe
36	6344.40.06	3	Sicherungskette kpl.		Safety chain cpl.	Chainette de securité cpl.



E1

Mulchscheibensatz 4,0+4,5m  
 Disk unit 4,0+4,5m  
 Disques mulcheur 4,0+4,5m

MegaSeed 4001 K2, 4501 K2 Br.2/ Serie 2

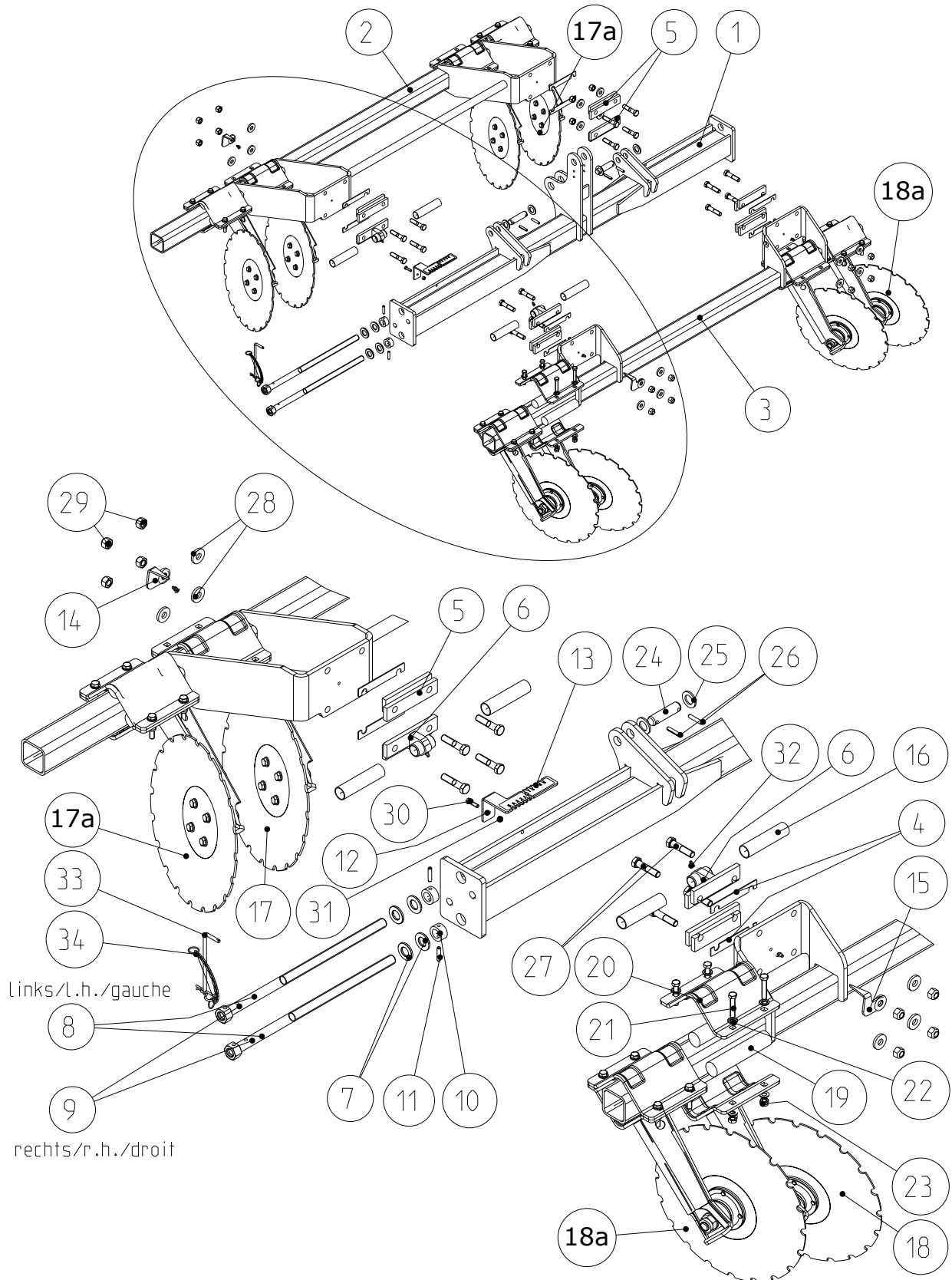



**E1**

Mulchscheibensatz  
Set of Mulch-Discs  
Disques mulcheur

**MegaSeed 4001 K2, 4501 K2 Br.2 / Serie 2**

Bild Ref. Fig.	Bestellnr. Part.-No. Référence	Stck Qty. Qte.	Bezeichnung	Technische Angaben Technical data Données techniques	Description	Désignation
	9032.73.10	1	RAHMEN, LINKS KPL.	4,0m	FRAME L.H. CPL.	BATI GAUCHE CPL.
	9032.73.11	1	RAHMEN, RECHTS KPL.	4,0m	FRAME R.H. CPL.	BATI DROIT CPL.
	9032.73.12	1	RAHMEN, LINKS KPL.	4,5m	FRAME L.H. CPL.	BATI GAUCHE CPL.
	9032.73.13	1	RAHMEN, RECHTS KPL.	4,5m	FRAME R.H. CPL.	BATI DROIT CPL.
1	6464.37.20	1	Mittelrahmen	4,0m-4,5m	Central frame	Bâti central
2	6464.26.31	1	Rahmen, vorn links	4,0m	Front frame l.h.	Bâti avant gauche
2	6464.26.33	1	Rahmen, vorn rechts	4,0m	Front frame r.h.	Bâti avant droit
2	6464.26.21	1	Rahmen, vorn links	4,5m	Front frame l.h.	Bâti avant gauche
2	6464.26.23	1	Rahmen, vorn rechts	4,5m	Front frame r.h.	Bâti avant droit
3	6464.26.32	1	Rahmen, hinten links	4,0m	Rear frame l.h.	Bâti arrière gauche
3	6464.26.34	1	Rahmen, hinten rechts	4,0m	Rear frame r.h.	Bâti arrière droit
3	6464.26.22	1	Rahmen, hinten links	4,5m	Rear frame l.h.	Bâti arrière gauche
3	6464.26.24	1	Rahmen, hinten rechts	4,5m	Rear frame r.h.	Bâti arrière droit
4	6464.37.42	8	Distanzblech		Plate	Tôle
5	6464.26.40	6	Verstellhalter		Adjuster	Piece de réglage
6	6464.37.41	2	Verstellung		Adjuster	Reglage
7	6436.30.05	4	Dichtscheibe	DW-9	Sealing washer	Joint
8	6464.26.60	2	Spindel	L=540 mm	Spindle	Manivelle
9	6464.26.59	2	Spindel	L=370 mm	Spindle	Manivelle
10	6464.26.48	2	Hülse		Sleeve	Douille
11	1481D840A	2	Spannstift	8x40 DIN1481 vz.	Dowel pin	Goupille serrage
12	6464.37.66	1	Verstellskala kpl.		Scale	Echelle graduée
13	9998.03.55	1	Aufkleber	"Verstellskala"	Sticker	Autocollant
14	6464.37.69	1	Verstellanzeiger, vorn		Front adjust.indicator	Jauge de réglage avant
15	6464.37.68	1	Verstellanzeiger, hinten		Rear adjust.indicator	Jauge de réglage arrière
16	6464.26.55	4	Säschlauchstück		Hose piece	Pièce de conduite
17	9031.13.01	6-9	MULCHSCHEIB.-EINH. VORN		FRONT DISC UNIT	DISQUE AVANT CPL.
18	9031.13.02	7,8	MULCHSCHEIB.-EINH. HINTEN		REAR DISC UNIT	DISQUE ARRIERE CPL.
17a	9031.13.07	1	RAND-MULCHSCH.-EINH. VORN		FRONT BORDER DISC	DISQUE BORD. AVANT CPL.
18a	9031.13.06	1	RAND-MULCHSCH.-EINH. HINT.		REAR BORDER DISC	DISQUE BORD. ARRIERE
19	9031.01.19	60-76	Gummi-Element		Rubber element	Elément silent
20	9031.01.10	15-19	Lagerblech		Plate	Tôle
21	933D1260PA	60-76	Sechskantschraube	M12x60 DIN933-8.8 vz.	Hex. bolt	Vis 6 pans
22	6916D13A	120-152	Scheibe	13 DIN 6916 vz.	Washer	Rondelle
23	985D12PA	60-76	Sechskantmutter	M12 DIN985-8 vz.	Hex.nut	Ecrou 6 pans



E2

Mulchscheiben-Einheit  
Disc unit  
Disque cpl.

Field Bird ab Br.1 /since Serie 1/à partir Série 1  
MegaSeed ab Br.1/since Serie 1/à partir Série 1

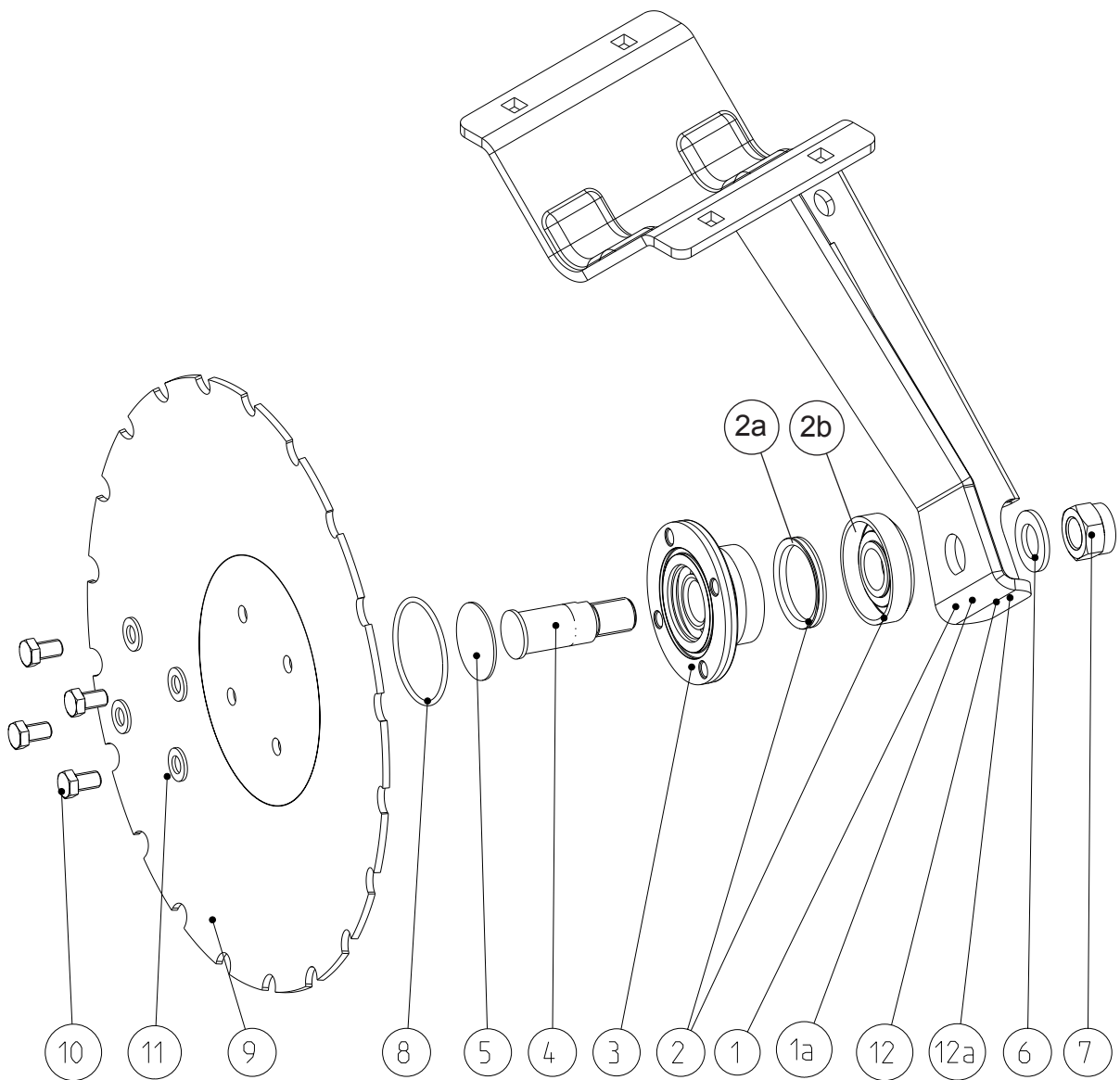

**E2**

Mulchscheiben-Einheit

 Disc unit  
 Disque cpl.

 Field Bird ab Br.1/since Serie 1/à partir Série 1  
 MegaSeed ab Br.1/since Serie 1/à partir Série 1

Bild Ref. Fig.	Bestellnr. Part.-No. Référence	Stck Qty. Qte.	Bezeichnung	Technische Angaben Technical data Données techniques	Description	Désignation
1-11	9031.13.01	1	MULCHSCHEIB.-EINH. VORN		FRONT DISC UNIT	DISQUE AVANT CPL.
2-12	9031.13.02	1	MULCHSCHEIB.-EINH. HINTEN		REAR DISC UNIT	DISQUE ARRIERE CPL.
1a-11	9031.13.07	1	RAND-MULCHSCH.-EINH. VORN		FRONT BORDER DIS	DISQUE BORD. AVANT CPL.
2-12a	9031.13.06	1	RAND-MULCHSCH.-EINH. HINT.		REAR BORDER DISC	DISQUE BORD. ARRIERE
1	9031.13.53	1	Scheibehalter vorne		Front disc bracket	Support disque avant
1a	9031.13.58	1	Randscheibehalter, vorn		Front border disc brack	Support disque bord.avant
2-11	9031.13.60	1	MULCHSCHEIBENSEGMENT		DISC UNIT	DISQUE CPL.
2a-2b	9031.13.31	1	DICHTUNGSPAKET KPL.		SEAL KIT CPL.	JEU DE JOINTS CPL.
2a	9031.13.33	1	V-Ring		Sealing ring	Joint
2b	9031.13.21	1	Stützhaube		Hood	Capot
3-5	9031.13.19	1	LAGEREINHEIT KPL.		BEARING CPL.	PALIER CPL.
3	9031.13.20	1	Lagereinheit		Bearing	Palier
4	9031.13.27	1	Bolzen kurz		Pin short	Axe court
5	9031.13.18	1	Verschlussscheibe		End lid	Couvercle de fermé
6	125DA25A	1	Scheibe	A25 DIN125 vz.	Washer	Rondelle
7	985D242PA	1	Sicherungsmutter	M24x2 DIN985-8 vz.	Hex.nut	Ecrou 6 pans
8	3771D713.55	1	O-Ring	71x3,55 N NBR70 DIN3771	O-seal	Joint torique
9	9031.13.29	1	Scheibe gezackt	SG-464Z (Ø460 mm)	Disc notched	Disque crénelé
10	961D1212520N	4	Sechskantschraube	M12x1,25x20 DIN961-10.9	Hex. bolt	Vis 6 pans
11	125DA13A	4	Scheibe	A13 DIN125 vz.	Washer	Rondelle
12	9031.13.52	1	Scheibehalter hinten		Rear disc bracket	Support disque arrière
12a	9031.13.57	1	Randscheibehalter, hinten		Rear border disc brack	Support disque bord.arrière

E3

Vibrazinken  
Vibra fine  
Dent droite

MegaSeed

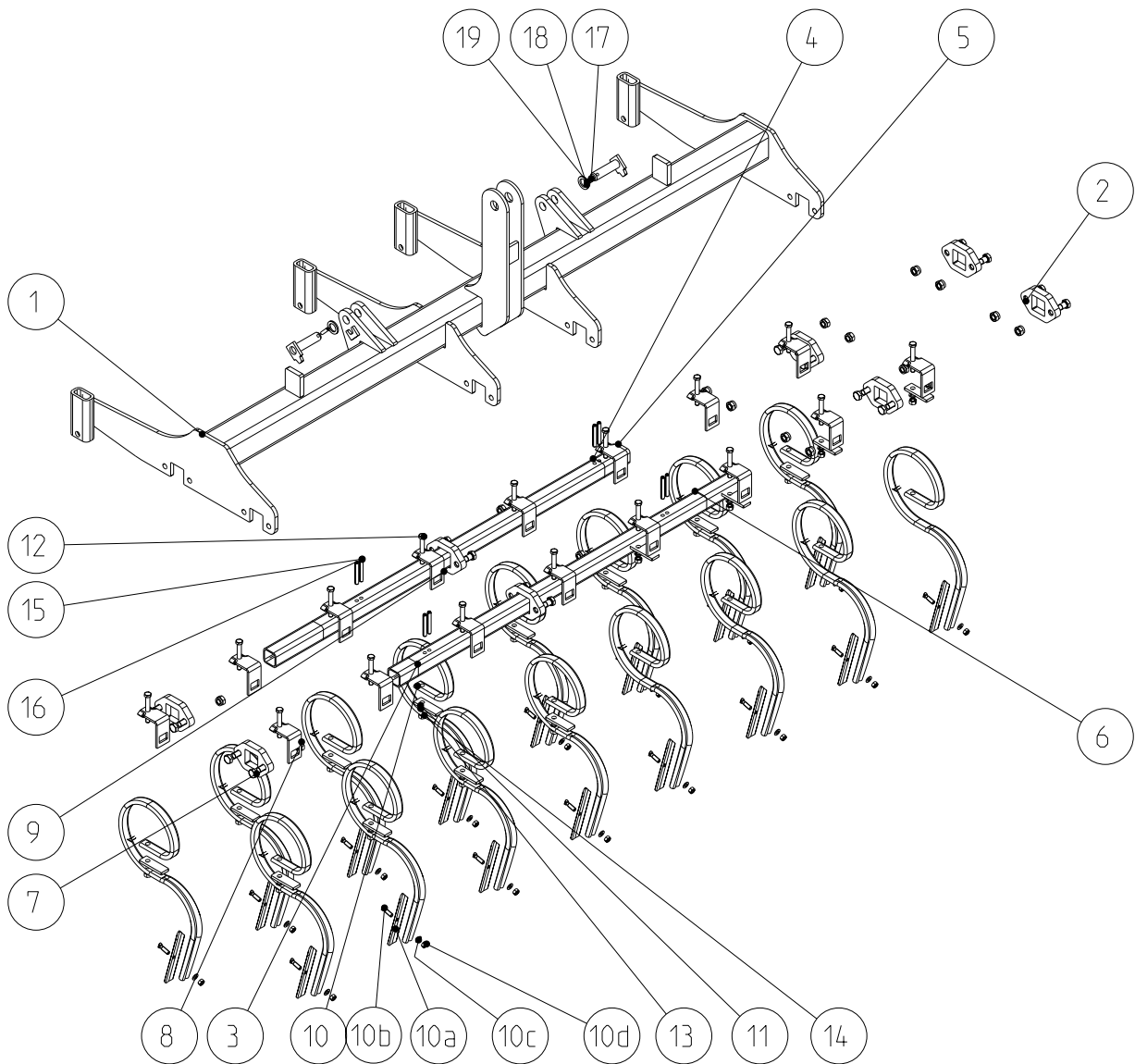



**E3**

Vibrazinken  
Vibra tine  
Dent droite

**MegaSeed**

Bild Ref. Fig.	Bestellnr. Part.-No. Référence	Stck Qty. Qte.	Bezeichnung	Technische Angaben Technical data Données techniques	Description	Désignation
1	9032.15.01	1	Werkzeugträger	3,0m	Trough	Caisson
1	9032.15.02	1	Werkzeugträger, links	4,0m	Trough l.h.	Caisson gauche
1	9032.15.03	1	Werkzeugträger, rechts	4,0m	Trough r.h.	Caisson droit
1	9032.15.04	1	Werkzeugträger, links	4,5m	Trough l.h.	Caisson gauche
1	9032.15.05	1	Werkzeugträger, rechts	4,5m	Trough r.h.	Caisson droit
2	6252.04.03	8	Lager		Bearing	Palier
3	9032.04.20	1	Zinkenträger, lang rechts	3,0m	Harrow bar long r.h.	Support de dente long dr
3	9032.04.30	1	Zinkenträger, lang rechts	4,0m	Harrow bar long r.h.	Support de dente long dr
3	9032.04.40	1	Zinkenträger, lang rechts	4,5m	Harrow bar long r.h.	Support de dente long dr
4	9032.04.21	1	Zinkenträger, lang links	3,0m	Harrow bar long l.h.	Support de dente long ga
4	9032.04.31	1	Zinkenträger, lang links	4,0m	Harrow bar long l.h.	Support de dente long ga
4	9032.04.41	1	Zinkenträger, lang links	4,5m	Harrow bar long l.h.	Support de dente long ga
5	9032.04.22	1	Zinkenträger, kurz rechts	3,0m	Harrow bar court r.h.	Support de dente court dr
5	9032.04.32	1	Zinkenträger, kurz rechts	4,0m	Harrow bar court r.h.	Support de dente court dr
5	9032.04.42	1	Zinkenträger, kurz rechts	4,5m	Harrow bar court r.h.	Support de dente court dr
6	9032.04.23	1	Zinkenträger, kurz links	3,0m	Harrow bar court l.h.	Support de dente court g
6	9032.04.33	1	Zinkenträger, kurz links	4,0m	Harrow bar court l.h.	Support de dente court g
6	9032.04.43	1	Zinkenträger, kurz links	4,5m	Harrow bar court l.h.	Support de dente court g
7	931D1655P	16	Sechskantschraube	M16x55 DIN931-8.8	Hex. bolt	Vis 6 pans
8	985D16PA	16	Sechskantmutter	M16 DIN985-8 vz.	Hex. nut	Ecrou 6 pans
9	6250.10.00	16-24	Befestigungsplatte		Plate	Plaquette
10-10d	6251.77.01	16-24	VIBRAZINKEN STEILST.		VIBRA TINE ASSEMB	DENT DROITE MONT.
10a	6251.77.03	16-24	Schar		Tip	Soc
10b	8007.18.04	16-24	Sondersenkschraube	SSS-10x38	C. sunk screw	Vis tête noyee
10c	126D11A	16-24	Scheibe	11 DIN126 vz.	Washer	Rondelle
10d	934D10PA	16-24	Sechskantmutter	M10 DIN934-8 vz.	Hex. nut	Ecrou 6 pans
11	6251.72.07	16-24	Beilage		Shim plate	Cale
12	931D1290P	16-24	Sechskantschraube	M12x90 DIN931-8.8	Hex. bolt	Vis 6 pans
13	127DA12A	16-24	Federring	A12 DIN127 vz.	Springwasher	Rondelle grower
14	934D12PA	16-24	Sechskantmutter	M12 DIN934-8 vz.	Hex. nut	Ecrou 6 pans
15	1481D1075A	8	Spannstift	10x75 DIN1481 vz.	Dowel pin	Goupille serrage
16	1481D675A	8	Spannstift	6x75 DIN1481 vz.	Dowel pin	Goupille serrage
17	1000.05.03	2,4	Bolzen		Pin	Axe
18	126D26A	2,4	Scheibe	26 DIN126 vz.	Washer	Rondelle
19	1481D845A	2,4	Spannstift	8x45 DIN1481 vz.	Dowel pin	Goupille serrage

**E4**

Messerrollege  
Rotary tiller  
Rotoculteur

**MR 3001 Br.4 / Serie 4**

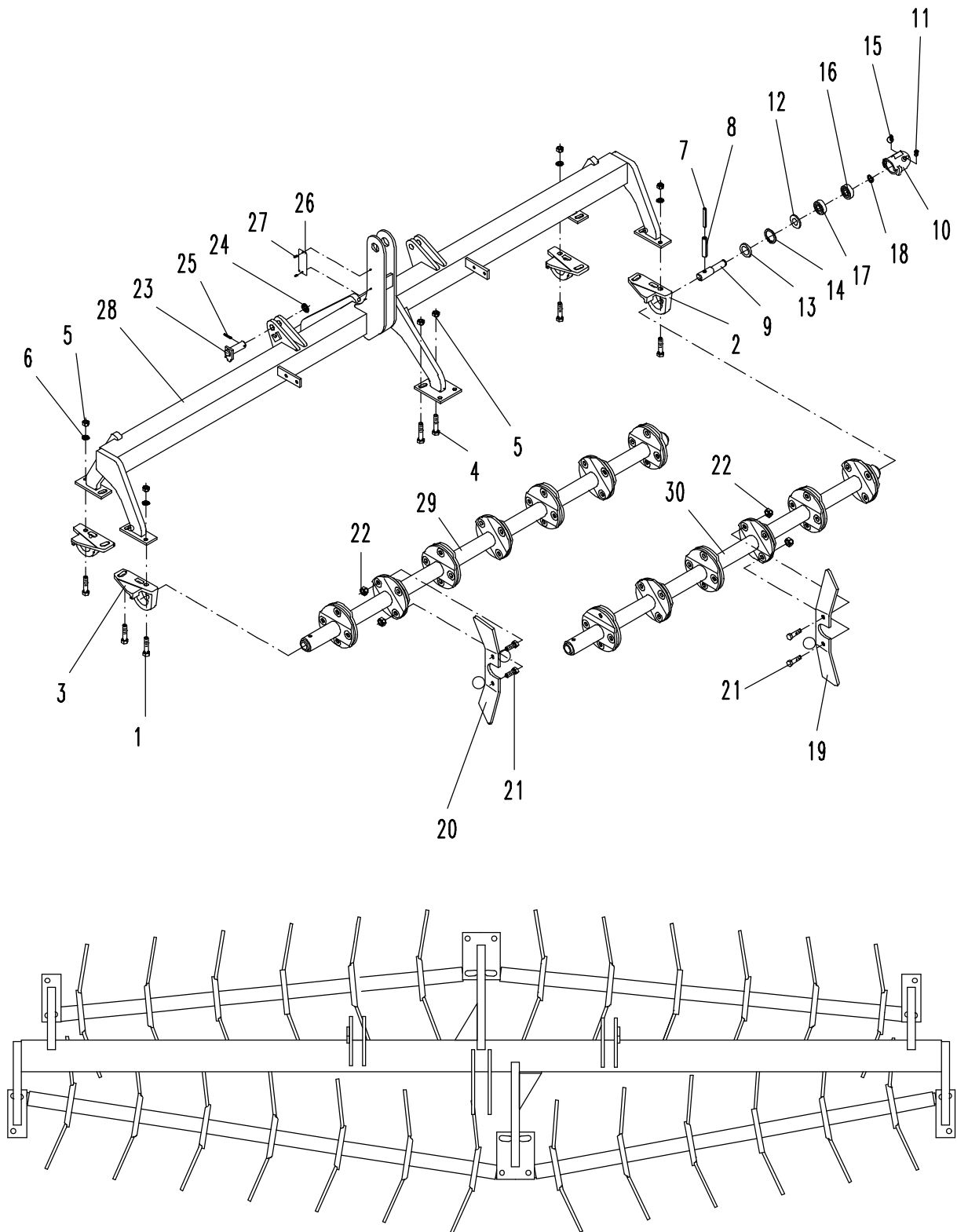

6462.06.01



**E4**

Messerrollegge  
Rotary tiller  
Rotoculteur

**MR 3001 Br.4 / Serie 4**

Bild Ref. Fig.	Bestellnr. Part.-No. Référence	Stck Qty. Qte.	Bezeichnung	Technische Angaben Technical data Données techniques	Description	Désignation
1	6439.04.01	4	Pendellager, li.versetzb.	LW-81	Bearing housing l.h.	Palier gauche
2	6439.04.02	4	Pendellager, re.versetzb.	LW-82	Bearing housing r.h.	Palier droit
3	933D1645P	14	Sechskantschraube	M16x45 DIN 933-8.8	Hex. bolt	Vis 6 pans
4	931D1650P	2	Sechskantschraube	M16x50 DIN931-8.8	Hex. Bolt	Vis 6 pans
5	980DV16PA	16	Sicherungsmutter	VM16 DIN980-8 vz.	Lock nut	Ecrou frein
6	6916D17	14	Scheibe	17 DIN6916	Washer	Rondelle
7	1481D645	8	Spannstift	6x45 DIN1481	Dowel pin	Goupille serrage
8	1481D1045	8	Spannstift	10x45 DIN1481	Dowel pin	Goupille serrage
9-18	6436.31.00	8	LAGER KURZ KPL.		BEARING SHORT	PALIER COURT CPL.
9	6455.35.02	1	Lagerbolzen		Shaft	Axe
10	6436.31.05	1	Lagergehäuse kurz		Bearing housing	Braquette
11	6436.31.04	1	Verschlussstopfen		Plug	Bouchon
12	6436.30.05	1	Dichtscheibe	DW-9	Sealing washer	Joint
13	6436.30.04	1	Dichtring	DW-20	Seal ring	Joint
14	472D471.75	1	Sicherungsring	47x1,75 DIN472	Circlip	Circlip
15	71412DA81	1	Schmiernippel	AM8x1 DIN71412	Grease nipple	Graisser
16	625D6204	1	Rillenkugellager	6204 DIN625	Ball bearing	Roulement à billes
17	625D6204RS	1	Rillenkugellager	6204 RS DIN625	Ball bearing	Roulement à billes
18	471D201.75	1	Sicherungsring	20x1,75 DIN471	Circlip	Circlip
19	6439.26.01	24	Messer rechts	SSG-37 RV	Blade r.h.	Bêche droit
20	6439.26.02	26	Messer links	SSG-37 LV	Blade l.h.	Bêche gauche
21	933D1240P	100	Sechskantschraube	M12x40 DIN933-8.8	Hex. bolt	Vis 6 pans
22	980DV12PA	100	Sicherungsmutter	VM12 DIN980-8 vz.	Lock nut	Ecrou frein
23	6611.53.01	2	Bolzen		Pin	Axe
24	1441D26	2	Scheibe	26 DIN1441	Washer	Rondelle
25	1481D840A	2	Spannstift	8x40 DIN1481 vz.	Dowel pin	Goupille serrage
26	1000.99.01	1	Typenschild		ID-plate	ID-plaque
27	1476D410	2	Halbrundkerbnagel	4x10 DIN1476	Rivet	Rivet
28	6462.02.01	1	Rahmen	3,0m	Beam	Bâti
29	6449.94.03	1	7er Messerwelle		7-bladeshaft	Arbre 7 bêches
30	6449.94.02	3	6er Messerwelle		6-bladeshaft	Arbre 6 bêches
.	.	.	.	.	.	.
.	.	.	.	.	.	.
.	.	.	.	.	.	.
.	.	.	.	.	.	.
.	.	.	.	.	.	.

**E5**

Messerrollege  
Rotary tiller  
Rotoculteur

**MR 4001 Br.4 /Serie 4**

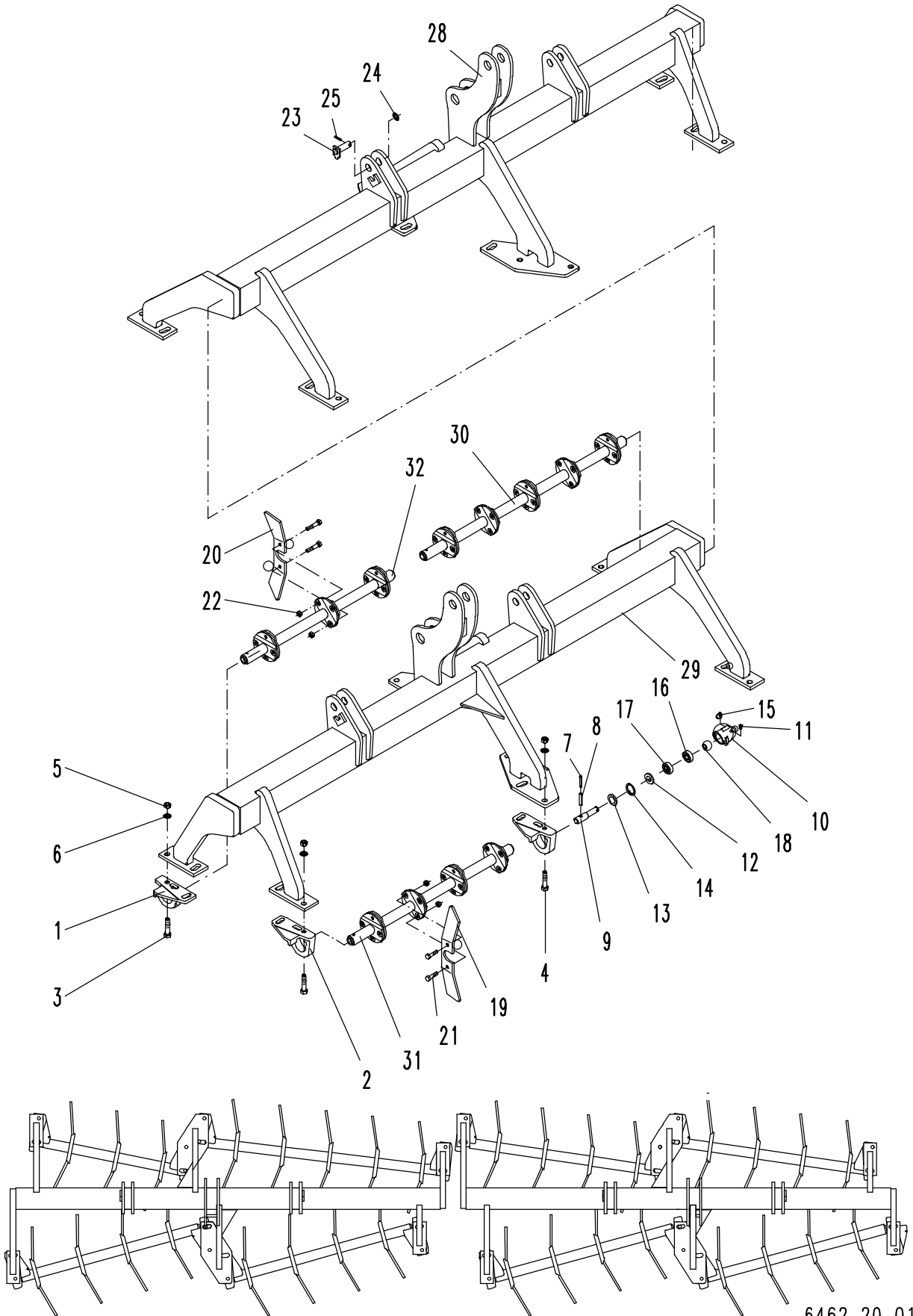

6462.20.01



**E5**

Messerrollegge  
Rotary tiller  
Rotoculteur

**MR 4001 Br.4 / Serie 4**

Bild Ref. Fig.	Bestellnr. Part.-No. Référence	Stck Qty. Qte.	Bezeichnung	Technische Angaben Technical data Données techniques	Description	Désignation
1	6439.04.01	4	Pendellager, li.versetzb.	LW-81	Bearing housing l.h.	Palier gauche
2	6439.04.02	12	Pendellager, re.versetzb.	LW-82	Bearing housing r.h.	Palier droit
3	933D1645P	28	Sechskantschraube	M16x45 DIN 933-8.8	Hex. bolt	Vis 6 pans
4	931D1650P	4	Sechskantschraube	M16x50 DIN931-8.8	Hex. Bolt	Vis 6 pans
5	980DV16PA	32	Sicherungsmutter	VM16 DIN980-8 vz.	Lock nut	Ecrou frein
6	6916D17	36	Scheibe	17 DIN6916	Washer	Rondelle
7	1481D645	16	Spannstift	6x45 DIN1481	Dowel pin	Goupille serrage
8	1481D1045	16	Spannstift	10x45 DIN1481	Dowel pin	Goupille serrage
.						
9-18	6436.31.00	16	LAGER KURZ KPL.		BEARING SHORT	PALIER COURT CPL.
9	6455.35.02	1	Lagerbolzen		Shaft	Axe
10	6436.31.05	1	Lagergehäuse kurz		Bearing housing	Braquette
11	6436.31.04	1	Verschlußstopfen		Plug	Bouchon
12	6436.30.05	1	Dichtscheibe	DW-9	Sealing washer	Joint
13	6436.30.04	1	Dichtring	DW-20	Seal ring	Joint
14	472D471.75	1	Sicherungsring	47x1,75 DIN472	Circlip	Circlip
15	71412DA81	1	Schmiernippel	AM8x1 DIN71412	Grease nipple	Graisser
16	625D6204	1	Rillenkugellager	6204 DIN625	Ball bearing	Roulement à billes
17	625D6204RS	1	Rillenkugellager	6204 RS DIN625	Ball bearing	Roulement à billes
18	471D201.75	1	Sicherungsring	20x1,75 DIN471	Circlip	Circlip
.						
19	6439.26.01	32	Messer rechts	SSG-37 RV	Blade r.h.	Bêche droit
20	6439.26.02	32	Messer links	SSG-37 LV	Blade l.h.	Bêche gauche
21	933D1240P	128	Sechskantschraube	M12x40 DIN933-8.8	Hex. bolt	Vis 6 pans
22	980DV12PA	128	Sicherungsmutter	VM12 DIN980-8 vz.	Lock nut	Ecrou frein
23	6611.53.01	2	Bolzen		Pin	Axe
24	1441D26	4	Scheibe	26 DIN1441	Washer	Rondelle
25	1481D840A	2	Spannstift	8x40 DIN1481 vz.	Dowel pin	Goupille serrage
.						
28	6462.19.01	1	Rahmen, rechts	4,0m	Beam r.h.	Bâti droit
29	6462.21.01	1	Rahmen, links	4,0m	Beam l.h.	Bâti dauche
30	6449.94.01	1	5er Messerwelle		5-bladeshaft	Arbre 5 bêches
31	6449.94.13	6	4er Messerwelle		4-bladeshaft	Arbre 4 bêches
32	6449.94.16	1	3er Messerwelle		3-bladeshaft	Arbre 3 bêches
.						
.						
.						
.						

**E6**

Messerrolle  
Rotary tiller  
Rotoculteur

**MR 4501 Br.4 / Serie 4**

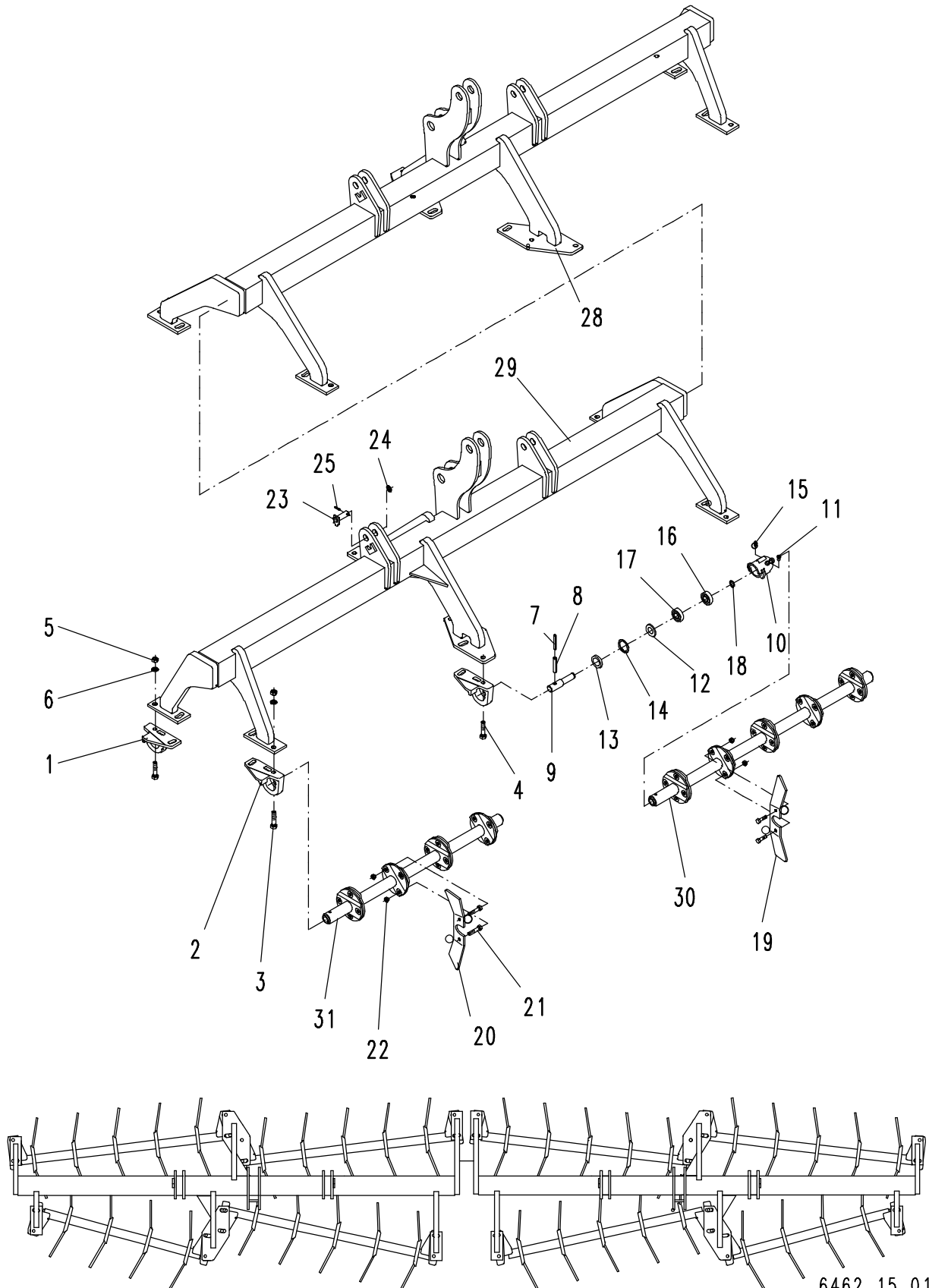

6462.15.01  
6462.15.02



**E6**

Messerrollegge  
Rotary tiller  
Rotoculteur

**MR 4501 Br.4 / Serie 4**

Bild Ref. Fig.	Bestellnr. Part.-No. Référence	Stck Qty. Qte.	Bezeichnung	Technische Angaben Technical data Données techniques	Description	Désignation
1	6439.04.01	4	Pendellager, li.versetzb.	LW-81	Bearing housing l.h.	Palier gauche
2	6439.04.02	12	Pendellager, re.versetzb.	LW-82	Bearing housing r.h.	Palier droit
3	933D1645P	16	Sechskantschraube	M16x45 DIN 933-8.8	Hex. bolt	Vis 6 pans
4	931D1650P	16	Sechskantschraube	M16x50 DIN931-8.8	Hex. Bolt	Vis 6 pans
5	980DV16PA	32	Sicherungsmutter	VM16 DIN980-8 vz.	Lock nut	Ecrou frein
6	6916D17	32	Scheibe	17 DIN6916	Washer	Rondelle
7	1481D645	16	Spannstift	6x45 DIN1481	Dowel pin	Goupille serrage
8	1481D1045	16	Spannstift	10x45 DIN1481	Dowel pin	Goupille serrage
.						
9-18	6436.31.00	16	LAGER KURZ KPL.		BEARING SHORT	PALIER COURT CPL.
9	6455.35.02	1	Lagerbolzen		Shaft	Axe
10	6436.31.05	1	Lagergehäuse kurz		Bearing housing	Braquette
11	6436.31.04	1	Verschlußstopfen		Plug	Bouchon
12	6436.30.05	1	Dichtscheibe	DW-9	Sealing washer	Joint
13	6436.30.04	1	Dichtring	DW-20	Seal ring	Joint
14	472D471.75	1	Sicherungsring	47x1,75 DIN472	Circlip	Circlip
15	71412DA81	1	Schmiernippel	AM8x1 DIN71412	Grease nipple	Graisser
16	625D6204	1	Rillenkugellager	6204 DIN625	Ball bearing	Roulement à billes
17	625D6204RS	1	Rillenkugellager	6204 RS DIN625	Ball bearing	Roulement à billes
18	471D201.75	1	Sicherungsring	20x1,75 DIN471	Circlip	Circlip
.						
19	6439.26.01	38	Messer rechts	SSG-37 RV	Blade r.h.	Bêche droit
20	6439.26.02	38	Messer links	SSG-37 LV	Blade l.h.	Bêche gauche
21	933D1240P	152	Sechskantschraube	M12x40 DIN933-8.8	Hex. bolt	Vis 6 pans
22	980DV12PA	152	Sicherungsmutter	VM12 DIN980-8 vz.	Lock nut	Ecrou frein
23	6611.53.01	4	Bolzen		Pin	Axe
24	1441D26	4	Scheibe	26 DIN1441	Washer	Rondelle
25	1481D840A	4	Spannstift	8x40 DIN1481 vz.	Dowel pin	Goupille serrage
.						
28	6462.14.01	1	Rahmen, rechts	4,5m	Beam r.h.	Bâti droit
29	6462.16.01	1	Rahmen, links	4,5m	Beam l.h.	Bâti gauche
30	6449.94.01	6	5er Messerwelle		5-bladeshaft	Arbre 5 bêches
31	6449.94.13	2	4er Messerwelle		4-bladeshaft	Arbre 4 bêches
.						
.						
.						
.						
.						

F

Radspurlockerer m. Vibrazinken  
 Eradicator with vibra fines  
 Effaceurs de trace avec dent vibro droite

MegaSeed, Field Bird

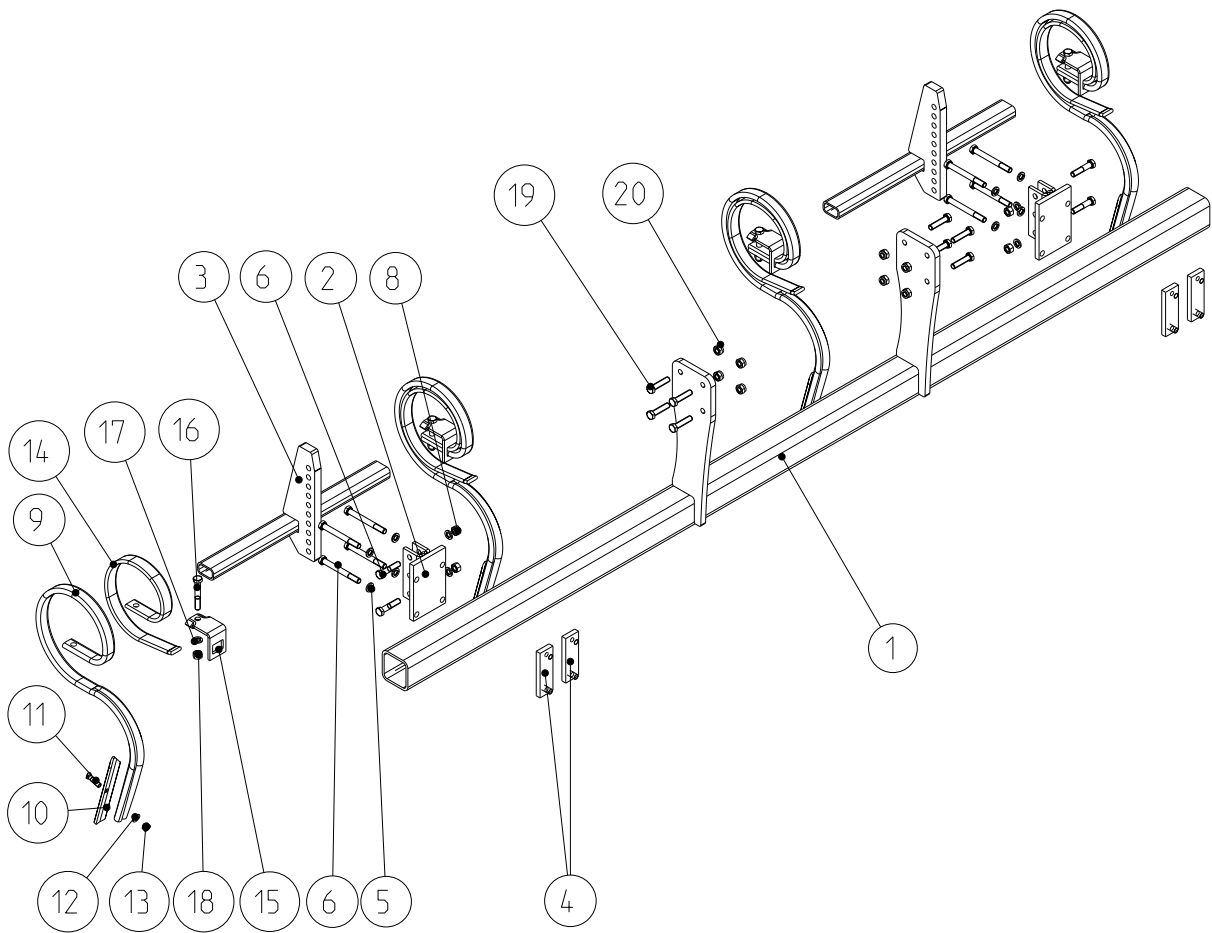

**F**

 Radspurlockerer m. Vibrazinken  
 Eradicator with vibra tines  
 Effaceurs de trace avec dent vibro droite

**MegaSeed, Field Bird**

Bild Ref. Fig.	Bestellnr. Part.-No. Référence	Stck Qty. Qte.	Bezeichnung	Technische Angaben Technical data Données techniques	Description	Désignation
1	9031.06.01	1	Rahmen		Beam	Bâti
2	6250.07.01	2	Halter		Bracket	Support
3	9019.21.01	2	Trägerrohr		Bracket	Support
4	6241.94.02	4	Gewindelasche		Latch	Plat
5	127DA12A	12	Federring	A12 DIN127 vz.	Springwasher	Rondelle grower
6	931D12110P	8	Sechskantschraube	M12x110 DIN931-8.8	Hex. bolt	Vis 6 pans
7	931D1255P	4	Sechskantschraube	M12x55 DIN931-8.8	Hex. bolt	Vis 6 pans
8	934D12PA	4	Sechskantmutter	M12 DIN934-8 vz.	Hex. nut	Ecrou 6 pans
9-17	9031.06.04	4	VIBRAZINKEN STEILST. KPL.		VIBRA TINES CPL.	DENT VIBRO DROITE CPL.
9	6251.77.01	4	VIBRAZINKEN STEILST.MONT		VIBRA TINE ASSEMBL.	DENT DROITE MONT.
10	6251.77.03	4	Schar		Tip	Soc
11	8007.18.04	4	Sondersenkschraube	SSS-10x38	C. sunk screw	Vis tête noyee
12	126D11A	4	Scheibe	11 DIN126 vz.	Washer	Rondelle
13	934D10PA	4	Sechskantmutter	M10 DIN934-8 vz.	Hex. nut	Ecrou 6 pans
14	8007.33.02	4	Verstärkungsfeder	VEG-14	Reinforcement	Renfort VEG-14
15	8007.43.03	4	Befestigungsplatte		Plate	Plaquette
16	931D1275N	4	Sechskantschraube	M12x75 DIN931-10.9	Hex. bolt	Vis 6 pans
17	127DA12A	4	Federring	A12 DIN127 vz.	Springwasher	Rondelle grower
18	934D12PA	4	Sechskantmutter	M12 DIN934-8 vz.	Hex. nut	Ecrou 6 pans
19	933D1250P	8	Sechskantschraube	M12x50 DIN933-8.8	Hex. bolt	Vis 6 pans
20	985D12PA	8	Sechskantmutter	M12 DIN985-8 vz.	Hex. nut	Ecrou 6 pans
.						
.						
.						
.						
.						
.						
.						
.						
.						
.						
.						
.						
.						
.						
.						
.						

F1

Radspurlockerer m. Kultureggenzinken  
 Eradicator with s-tines  
 Effaceurs de trace avec dent vibrante

MegaSeed, Field Bird

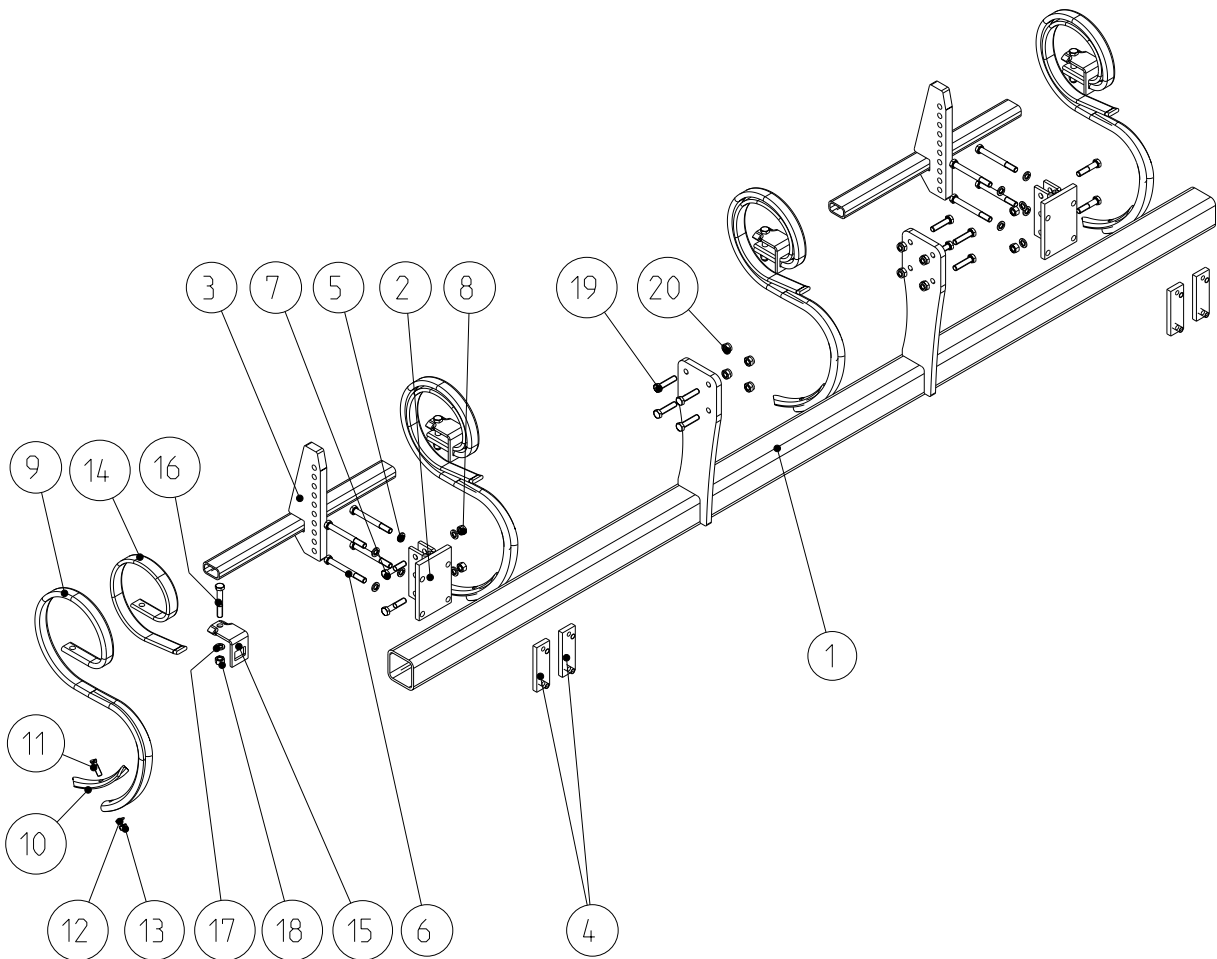



G

Zinkenschlepe hydr.  
 Leveller hydr.  
 Tôle nivel à crampon

MegaSeed 3001 S

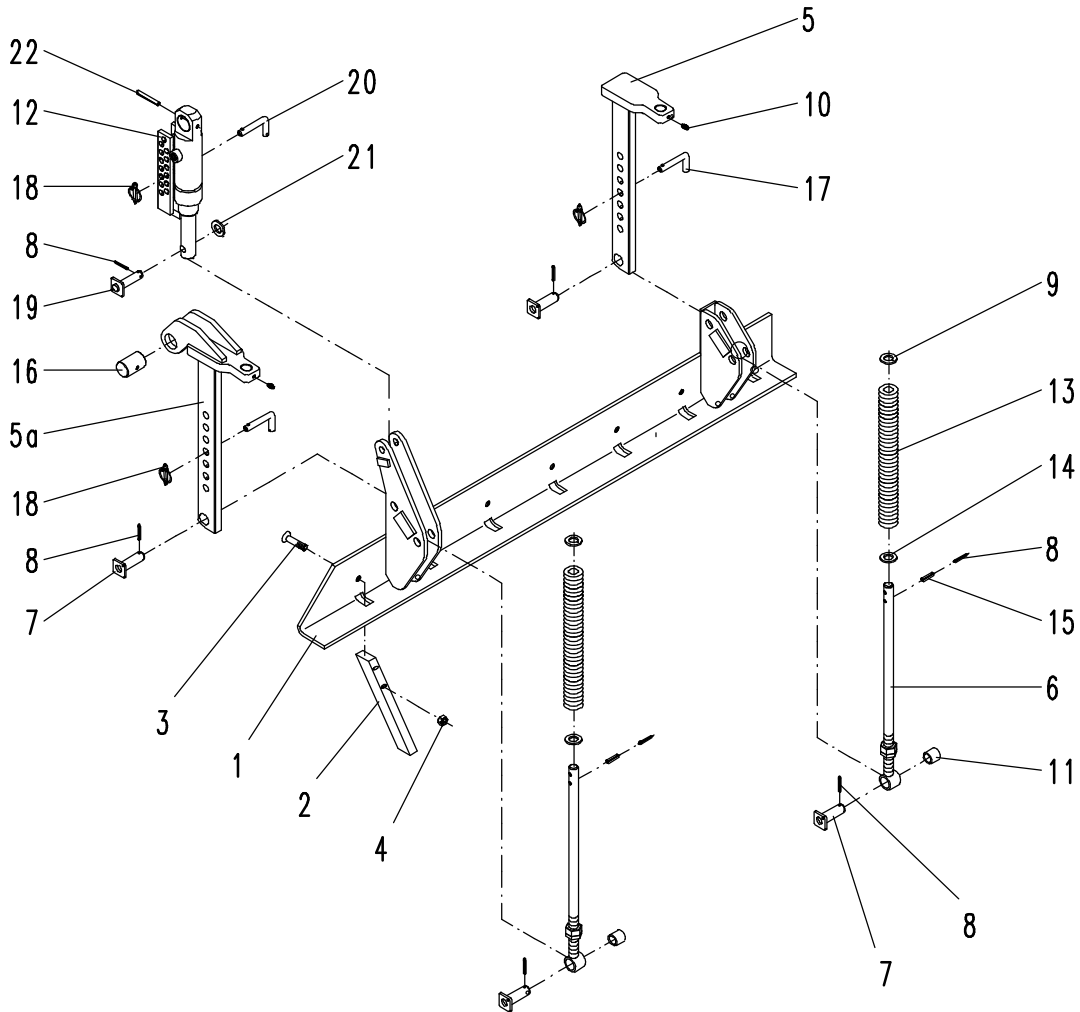



**G**

Zinkenschleppe hydr.  
 Leveller hydr.  
 Tôle nivel à crampon

**MegaSeed 3001 S**

Bild Ref. Fig.	Bestellnr. Part.-No. Référence	Stck Qty. Qte.	Bezeichnung	Technische Angaben Technical data Données techniques	Description	Désignation
1	6253.47.22	1	Schleppbalken, links	3,0m	Levelling bar l.h.	Plat niveleur gauche
1a	6253.47.23	1	Schleppbalken, rechts	3,0m	Levelling bar r.h.	Plat niveleur droit
2	6253.48.01	14	Zinken		Tine	Dent
3	7991D1250P	14	Senkschraube	M12x50 DIN7991-8.8	C. sunk screw	Vis tête noyee
4	934D12PA	14	Sechskantmutter	M12 DIN934-8 vz.	Hex. nut	Ecrou 6 pans
5	6337.43.12	2	Stiel		Stalk	Tige
5a	6337.43.13	2	Stiel		Stalk	Tige
6	6337.81.01	4	Druckstange		Compr. rod	Bras de levier
7	6337.45.03	8	Drehbolzen	Ø20 mm	Pin	Axe
8	1481D530A	14	Spannstift	5x30 DIN1481 vz.	Dowel pin	Goupille serrage
9	1441D21A	4	Scheibe	21 DIN1441 vz.	Washer	Rondelle
10	4716.38.00	4	Schmiernippel	H1 8x1 KX-1	Grease nipple	Graisneur
11	6241.47.01	4	Polypenco-Buchse	26,15x20,25x24	Bush	Bague
	.					
12	8171.06.01	2	ZYLINDER KPL.	40/96/310	CYLINDER CPL.	VERIN CPL.
	8171.05.02		Dichtungssatz		Seal kit	Jeu de joints
	.					
13	6337.48.15	4	Druckfeder	DF-269,5	Compression spring	Ressort
14	125DA21A	4	Scheibe	A21 DIN125 vz.	Washer	Rondelle
15	1481D830	4	Spannstift	8x30 DIN1481	Dowel pin	Goupille serrage
16	8163.01.01	2	Haltestück		Guide	Axe
17	8409.55.00	4	Steckstock	TB-16x80 A	Pin	Axe
18	8405.12.09	6	Klappstecker	STB-4,5x340	Linch-pin	Goupille auto.
19	6349.16.01	2	Bolzen	Ø16 mm	Pin	Axe
20	6241.29.02	2	Steckstock	TB-12x50	Pin	Axe
21	1441D17A	2	Scheibe	17 DIN1441 vz.	Washer	Rondelle
22	1481D860A	2	Spannstift	8x60 DIN1481 vz.	Dowel pin	Goupille serrage
	.					
	.					
	.					
	.					
	.					
	.					
	.					
	.					
	.					

**G1**

Zinkenschlepe hydr.  
 Leveller hydr.  
 Tôle nivel à crampon

**MegaSeed 4001 K2,4501 K2**



**G1**

 Zinkenschleppe hydr.  
 Leveller hydr.  
 Tôle nivel à crampon

**MegaSeed 4001 K2, 4501 K2**

Bild Ref. Fig.	Bestellnr. Part.-No. Référence	Stck Qty. Qte.	Bezeichnung	Technische Angaben Technical data Données techniques	Description	Désignation
1	6253.92.12	1	Schleppbalken, links	4,0m	Levelling bar l.h.	Plat niveleur gauche
1	6253.92.10	1	Schleppbalken, links	4,5m	Levelling bar l.h.	Plat niveleur gauche
1a	6253.92.13	1	Schleppbalken, rechts	4,0m	Levelling bar r.h.	Plat niveleur droit
1a	6253.92.11	1	Schleppbalken, rechts	4,5m	Levelling bar r.h.	Plat niveleur droit
2	6253.48.01	20,22	Zinken		Tine	Dent
3	7991D1250P	20,22	Senkschraube	M12x50 DIN7991-8.8	C. sunk screw	Vis tête noyee
4	934D12PA	20,22	Sechskantmutter	M12 DIN934-8 vz.	Hex. nut	Ecrou 6 pans
5	6337.43.13	4	Stiel		Stalk	Tige
6	6337.81.01	4	Druckstange		Compr. rod	Bras de levier
7	6337.45.03	8	Drehbolzen	Ø20 mm	Pin	Axe
8	1481D530A	16	Spannstift	5x30 DIN1481 vz.	Dowel pin	Goupille serrage
9	1441D21A	4	Scheibe	21 DIN1441 vz.	Washer	Rondelle
10	4716.38.00	4	Schmiernippel	H1 8x1 KX-1	Grease nipple	Graisneur
11	6241.47.01	4	Polypenco-Buchse	26,15x20,25x24	Bush	Bague
.						
12	8171.06.01 8171.05.02	4	ZYLINDER KPL. Dichtungssatz	40/96/310	CYLINDER CPL. Seal kit	VERIN CPL. Jeu de joints
.						
13	6337.48.15	4	Druckfeder	DF-269,5	Compression spring	Ressort
14	125DA21A	4	Scheibe	A21 DIN125 vz.	Washer	Rondelle
15	1481D830	4	Spannstift	8x30 DIN1481	Dowel pin	Goupille serrage
16	8163.01.01	4	Haltestück		Guide	Axe
17	8409.55.00	4	Steckstock	TB-16x80 A	Pin	Axe
18	8405.12.09	8	Klappstecker	STB-4,5x340	Linch-pin	Goupille auto.
19	6349.16.01	4	Bolzen	Ø16 mm	Pin	Axe
20	6241.29.02	4	Steckstock	TB-12x50	Pin	Axe
21	1441D17A	4	Scheibe	17 DIN1441 vz.	Washer	Rondelle
22	1481D860A	4	Spannstift	8x60 DIN1481 vz.	Dowel pin	Goupille serrage
.						
.						
.						
.						
.						
.						
.						
.						
.						
.						
.						

H

Beladesteg  
Loading platform  
Passerelle de chargement

MegaSeed

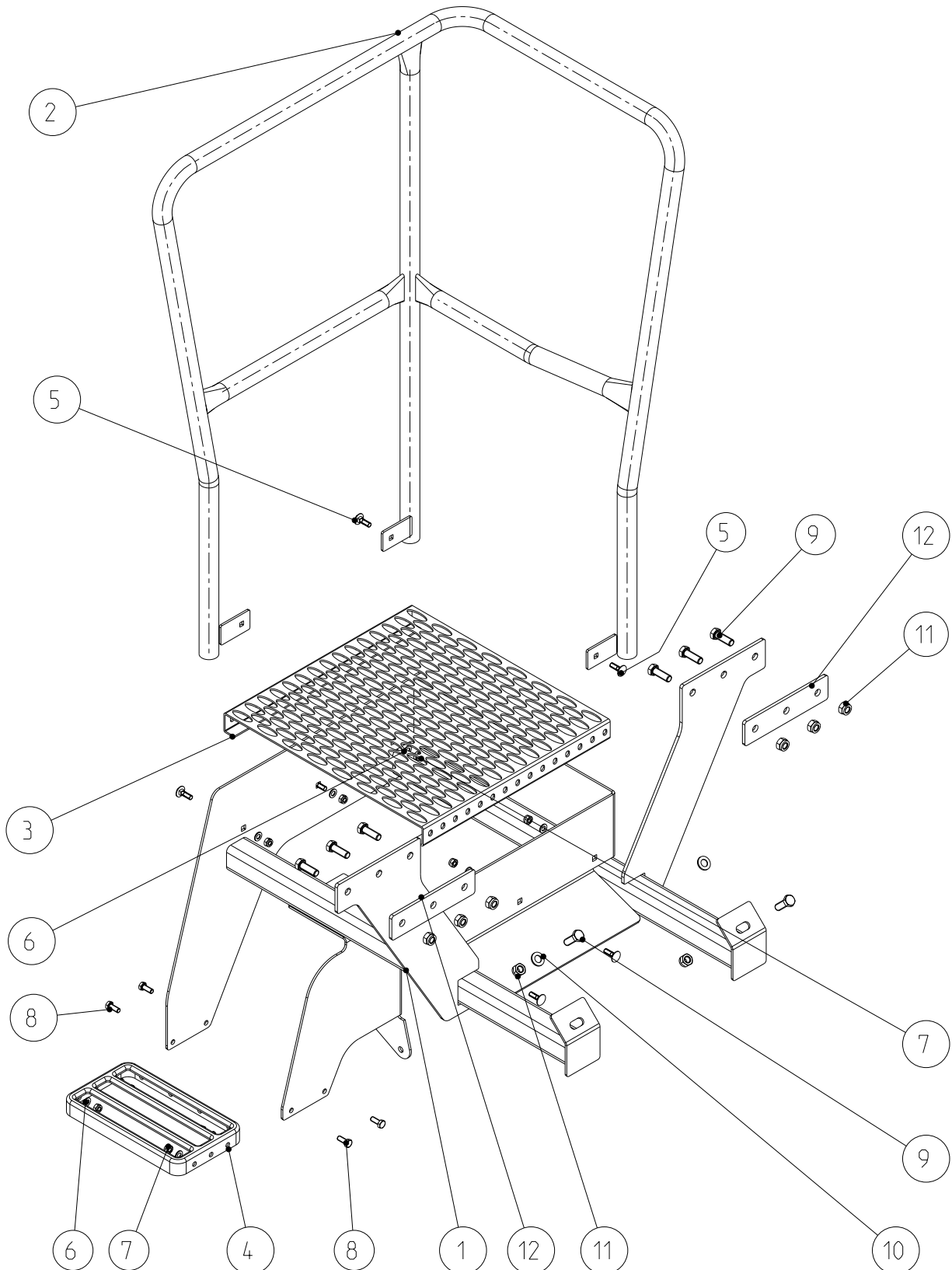



H1

Beladerost  
Filling platform  
Rampe de chargement

MegaSeed





**H1**

Beladerost  
Filling platform  
Rampe de chargement

**MegaSeed**

Bild Ref. Fig.	Bestellnr. Part.-No. Référence	Stck Qty. Qte.	Bezeichnung	Technische Angaben Technical data Données techniques	Description	Désignation
1-16	9031.26.01	1	BELADEROST	3,0m	FILLING PLATFORM	RAMPE DE CHARGEM.
1-22	9031.26.02	1	BELADEROST	4,0m	FILLING PLATFORM	RAMPE DE CHARGEM.
1-22	9031.26.03	1	BELADEROST	4,5m	FILLING PLATFORM	RAMPE DE CHARGEM.
.						
1	9031.26.11	1	Laufrost	3,0m		
1	9031.26.12	1	Laufrost	4,0m		
1	9031.26.13	1	Laufrost	4,5m		
2	9031.20.01	1	Geländer-Aufstieg			
.						
3-8	9031.25.01	1	AUFSTIEG MONT.			
3	9031.14.23	1	Aufstieg, rechts	3,0m-4,5m		
4	9031.14.22	1	Aufstieg, links	3,0m-4,5m		
5	9031.21.10	2	Universalauftritt			
6	603D820PA	8	Flachrundschrabe	M 8x20 DIN603-8.8 vz.	Bolt	Vis
7	126D9	8	Scheibe	9 DIN126	Washer	Rondelle
8	985D8PA	8	Sechskantmutter	M8 DIN985-8 vz.	Hex.nut	Ecrou 6 pans
.						
9	9031.14.21	2	Lagerverstärkung			
10	9031.26.22	2	Geländer-Verstärkung			
11	933D1245PA	2	Sechskantschraube	M12x45 DIN933-8.8 vz.	Hex. bolt	Vis 6 pans
12	125DA13A	10	Scheibe	A13 DIN125 vz.	Washer	Rondelle
13	985D12PA	2	Sechskantmutter	M12 DIN985-8 vz.	Hex. nut	Ecrou 6 pans
14	603D830PA	16-18	Flachrundschrabe	M8x30 DIN603-8.8 vz.	Bolt	Vis
15	126D9	16-18	Scheibe	9 DIN126	Washer	Rondelle
16	985D8PA	16-18	Sechskantmutter	M8 DIN985-8 vz.	Hex.nut	Ecrou 6 pans
17	9031.20.12	1	Halter		Bracket	Support
.						
18-22	9031.26.50	1	STÜTZE F.GELÄNDER		STAND CPL.	BEQUILLE CPL.
18	9031.26.40	1	Abstützung f.Geländer		Strut	Support
19	9001.00.31	1	T-Schelle geteilt	1"x3/4	T-Clip	Raccord
20	8406.33.02	1	Schraubband	MC-12X93X115	Cross section	Bride
21	125DA13A	2	Scheibe	A13 DIN125 vz.	Washer	Rondelle
22	985D12PA	2	Sechskantmutter	M12 DIN985-8 vz.	Hex. nut	Ecrou 6 pans
.						
.						
.						
.						
.						

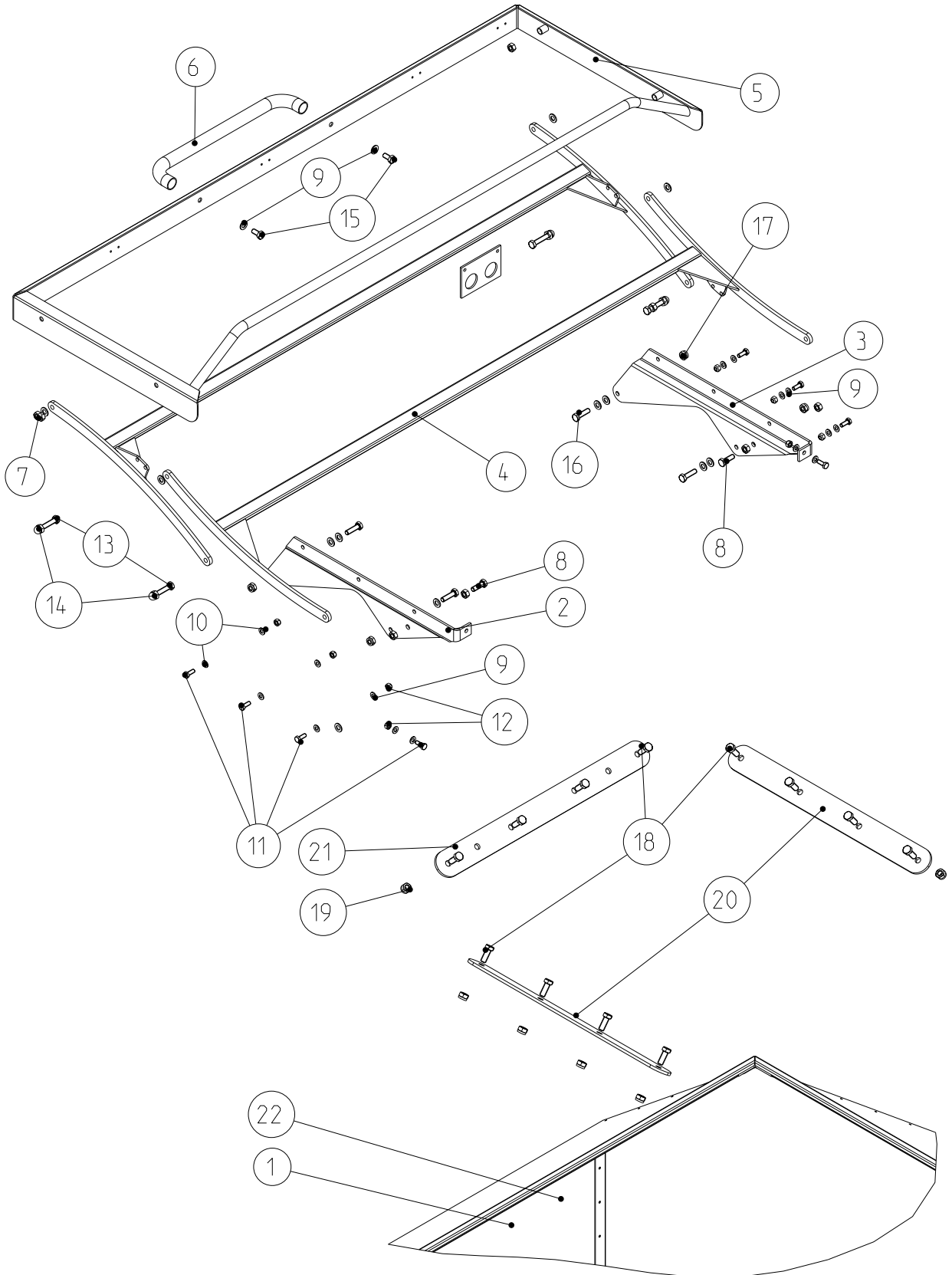



J1

Halter  
Bracket  
Support

MegaSeed

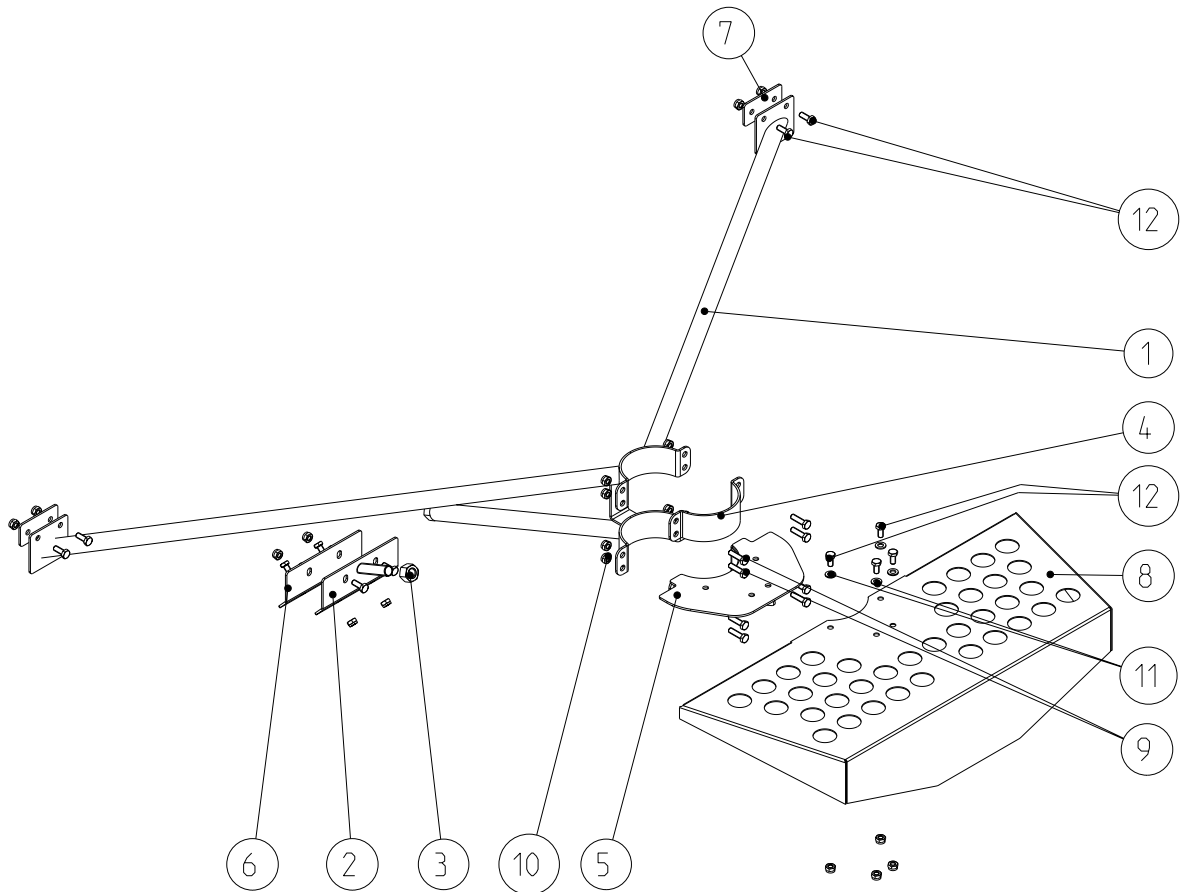



J3

Saattank  
Hopper  
Trémie

MegaSeed 6002 K2

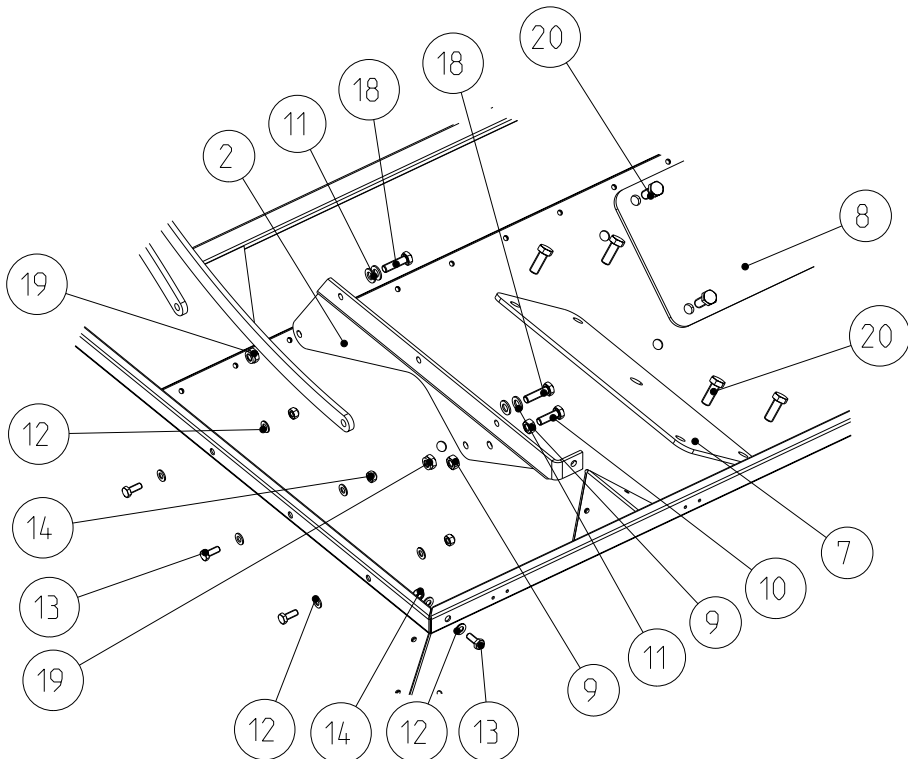
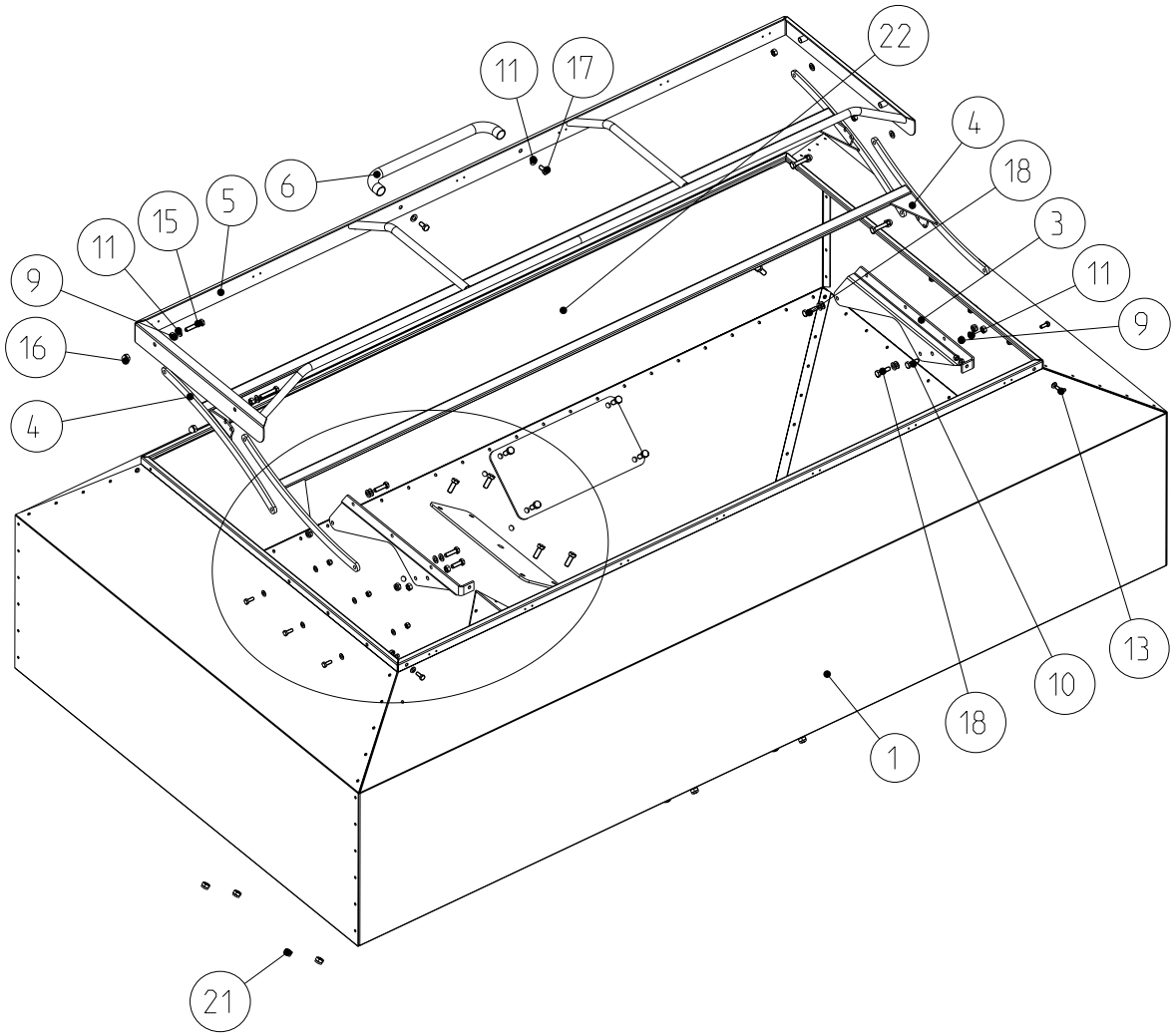



**J3**

Doppeltank  
Double hopper  
Double trémie

**MegaSeed 6002 K2 Br./Serie 3**

Bild Ref. Fig.	Bestellnr. Part.-No. Référence	Stck Qty. Qte.	Bezeichnung	Technische Angaben Technical data Données techniques	Description	Désignation
1-21	9032.50.01	1	DOPELTANK KPL.		DOUBLE HOPPER CPL.	DOUBLE TREMIE CPL.
.	.	.	.	.	.	.
1	9032.51.01	1	Doppeltank		Double hopper	Double trémie
2	9031.12.81	1	Halter, links		Bracket	Support
3	9031.12.82	1	Halter, rechts		Bracket	Support
4	9032.53.01	2	Hebel		Lever	Levier
5	9032.52.01	1	Planenrahmen		Awning frame	Bâti de bâche
6	9032.11.05	1	Griff		Handle	Broche
7	9032.50.21	2	Verstärkung, seitlich		Side reinforcement	Renforts latéral
8	9032.50.22	1	Verstärkung, hinten		Rear reinforcement	Renforts arrière
9	934D10PA	8	Sechskantmutter	M10 DIN934-8 vz.	Hex. nut	Ecrou 6 pans
10	933D1030PA	2	Sechskantschraube	M10x30 DIN933-8.8 vz.	Hex. bolt	Vis 6 pans
11	126D11A	16	Scheibe	11 DIN126 vz.	Washer	Rondelle
12	125DA8.4A	16	Scheibe	A8,4 DIN125 vz.	Washer	Rondelle
13	933D820PA	8	Sechskantschraube	M8x20 DIN933-8.8 vz.	Hex. bolt	Vis 6 pans
14	980DV8PA	8	Sicherungsmutter	VM8 DIN980-8 vz.	Lock nut	Ecrou frein
15	933D1050PA	4	Sechskantschraube	M10x50 DIN933-8.8 vz.	Hex. bolt	Vis 6 pans
16	1587D10QA	4	Hutmutter	M10 DIN1587-6 vz.	Cap nut	Ecrou à chapeau
17	933D1020PA	2	Sechskantschraube	M10x20 DIN933-8.8 vz.	Hex. bolt	Vis 6 pans
18	933D1035PA	4	Sechskantschraube	M10x35 DIN933-8.8 vz.	Hex. bolt	Vis 6 pans
19	985D10PA	4	Sechskantmutter	M10 DIN985-8 vz.	Hex.nut	Ecrou 6 pans
20	933D1230PA	16	Sechskantschraube	M12x30 DIN933- 8.8 vz.	Hex. bolt	Vis 6 pans
21	985D12PA	16	Sechskantmutter	M12 DIN985-8 vz.	Hex.nut	Ecrou 6 pans
22	9032.50.10	1	Abdeckplane f.Doppeltank		Awning	Bâche
.	.	.	.	.	.	.
.	.	.	.	.	.	.
.	.	.	.	.	.	.
.	.	.	.	.	.	.
.	.	.	.	.	.	.
.	.	.	.	.	.	.
.	.	.	.	.	.	.
.	.	.	.	.	.	.
.	.	.	.	.	.	.
.	.	.	.	.	.	.
.	.	.	.	.	.	.
.	.	.	.	.	.	.
.	.	.	.	.	.	.
.	.	.	.	.	.	.

**K**

Dosierung  
Metering unit  
Distribution

**MegaSeed**

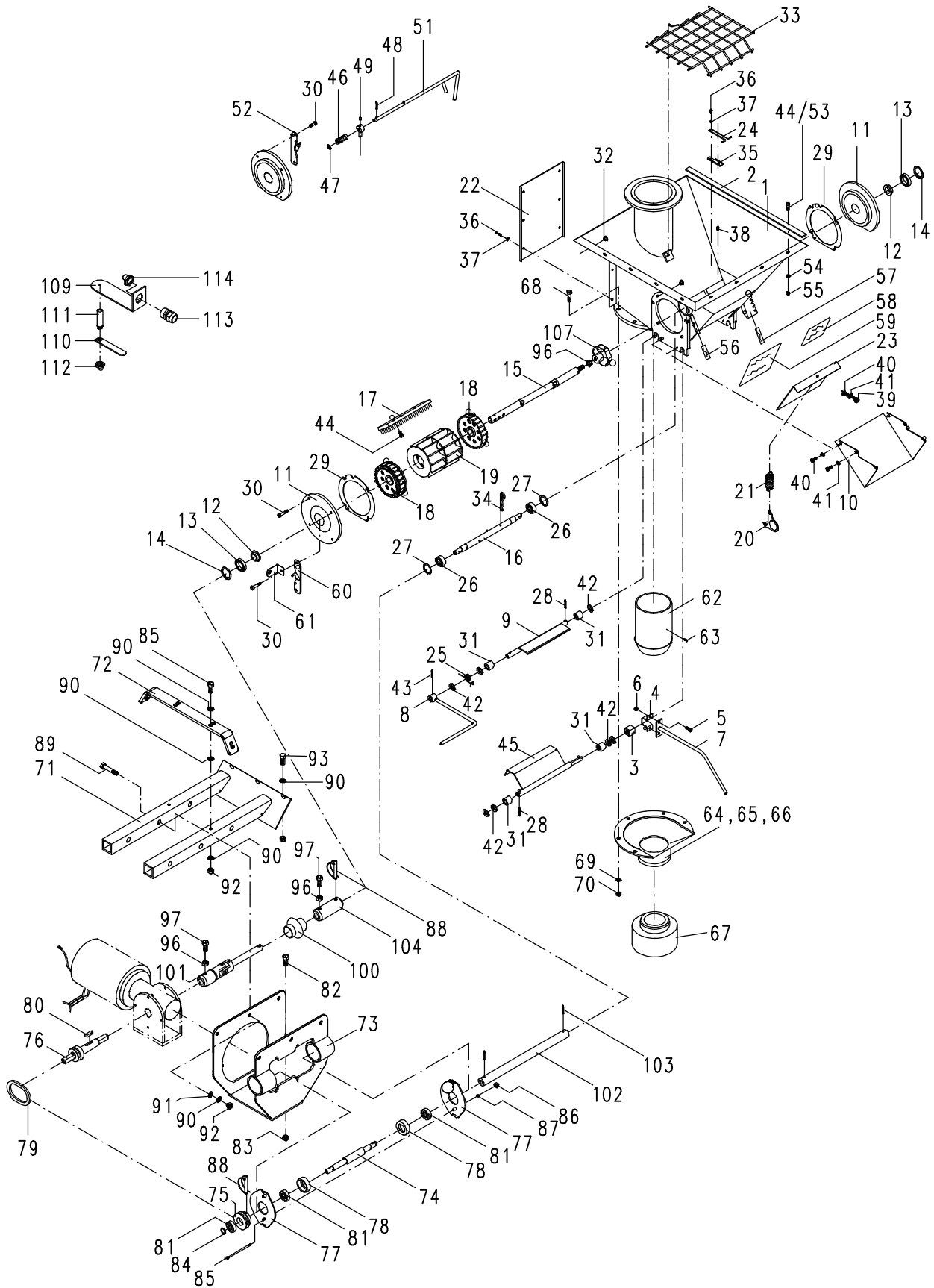

**K**

 Dosierung  
 Metering unit  
 Distribution

**MegaSeed**

Bild Ref. Fig.	Bestellnr. Part.-No. Référence	Stck Qty. Qte.	Bezeichnung	Technische Angaben Technical data Données techniques	Description	Désignation
1-114	9032.21.01	1	DOSIERUNG KPL.		METERING UNIT	DISTRIBUTION
1	9001.16.01	1	Dosiergehäuse		Distribution housing	Carter de distribution
2	8409.31.20	1	Flachdichtung	15x4x1850	Seal	Joint
3-7	9001.18.01	1	BODENKLAPPENHEBEL		LEVER CPL.	LEVIER DE LIGNET CPL
3	9001.18.05	1	Gummifederelement		Rubber spring	Silent bloc
4	9001.18.06	1	Bügel		Fastener	Support
5	933D612PA	2	Sechskantschraube	M6x12 DIN933-8.8 vz.	Hex. bolt	Vis 6 pans
6	985D6PA	2	Sechskantmutter	M6 DIN985-8 vz.	Hex. nut	Ecrou 6 pans
7	9001.18.02	1	Bodenklappenhebel		Lever	Levier de linguet
8	9001.19.11	1	Abdrehklappenhebel			
9	9001.20.01	1	Abdrehklappe		Calibration flap	Trappe de contrôle
10	9001.25.01	1	Auslaufstutzen		Dischargefunnel	Etonnoir d'écoulement
11-15	9001.86.01	2	LAGERDECKEL		BEARING COVER	COUVERCLE CPL.
11	9001.86.03	4	Lagerdeckel		Bearing cover	Couvercle
12	9001.86.02	4	Reduzierbuchse		Bush	Baque
13	625D618052RS	4	Rillenkugellager	61805 2RS DIN625	Ball bearing	Roulement à billes
14	472D371.5	4	Sicherungsring	37x1,5 DIN472	Circlip	Circlip
15	9001.15.03	2	Dosierwelle		Metering shaft	Arbre de dosage
16	9001.15.04	1	Rührwelle verzinkt		Agitator shaft	Arbre agitateur
17	9001.15.05	1	Reinigungsbürste		Cleaner brush	Brosse nettoyante
18	9001.15.06	2	Feindosierrad		Fine seed wheel	Roue à petite cannel.
19	9001.24.01	1	Grobdosierrad		Standard seed wheel	Roue à grandes cannel.
20	9001.15.17	1	Schiebesicherungshaken		Safety	Chrochet
21	9002.00.09	1	Scharhaltefeder		Tension spring	Ressort
22	9001.15.07	1	Rückwand		Backplate	Paroi arrière
23	9001.15.08	1	Absperrschieber		Shutter	Trappe de vidange
24	9001.15.09	2	Reinigungsfeder		Cleaner spring	Ressort de nettoyage
25	9001.15.10	1	Abdrehklappenfeder		Spring	Ressort
26	625D60022RS1	2	Rillenkugellager	6002 2RS1 DIN625	Ball bearing	Roulement à billes
27	472D321.2	2	Sicherungsring	32x1,2 DIN472	Circlip	Circlip
28	1481D3.520A	3	Spannstift	3,5x20 DIN1481 vz.	Dowel pin	Goupille serrage
29	9001.15.11	3	Ausgleichscheibe verzinkt		Spacer	Cale
30	9001.95.01	8	Tensilockschraube	M6x16 vz.	Tensi lock bolt	Vis tensi



**K**

Dosierung  
Metering unit  
Distribution

**MegaSeed**

Bild Ref. Fig.	Bestellnr. Part.-No. Référence	Stck Qty. Qte.	Bezeichnung	Technische Angaben Technical data Données techniques	Description	Désignation
31	9001.15.13	4	Bundbuchse	12-16-20	Collar bush	Douille à collet
32	9108.74.04	6	Abdeckkappe	DP-312 NR2613		
33	9001.15.12	1	Schutzsieb		Sieve	Grille de protection
34	9001.15.14	3	Rührstecker		Agitator finger	Doigt agitateur
35	9001.15.15	2	Federführung		Spring guide	Guide
36	7976DB6.316A	8	Blechschaube	BM6,3x16 DIN7976 vz.	Self-tapping srew	Vis
37	9021DA6.4A	8	Scheibe	A 6.4 DIN9021 vz.	Washer	Rondelle
38	7337D48A	2	Blindniet	4x8 DIN7337 vz.	Blind rivet	Rivet
39	1587D6QA	1	Hutmutter	M6 DIN1587-6 vz.	Cap nut	Ecrou à chapeau
40	933D612PA	5	Sechskantschraube	M6x12 DIN933-8.8 vz.	Hex. bolt	Vis 6 pans
41	125DA6.4A	10	Scheibe	A 6.4 DIN125 vz.	Washer	Rondelle
42	125DA13A	6	Scheibe	A13 DIN125 vz.	Washer	Rondelle
43	1481D526A	1	Spannstift	5x26 DIN1481 vz.	Dowel pin	Goupille serrage
44	933D620PA	7	Sechskantschraube	M6x20 DIN933-8.8 vz.	Hex. bolt	Vis 6 pans
45	9001.21.01	1	Bodenklappe		Bottom flap	Linguet
46	4716.12.00	1	Druckfeder	DF-80	Compression spring	Ressort
47	125DA8.4A	1	Scheibe	A8,4 DIN125 vz.	Washer	Rondelle
48	94D3216A	1	Splint	3,2x16 DIN94 vz.	Splint pin	Goupille fendue
49	916D58A	1	Gewindestift	5x8 DIN916 vz.	Threaded pin	Vis sans fete
50	9001.82.01	1	Riegelwelle, links		Locking shaft l.h.	Axe de verrou gauche
51	9001.83.01	1	Riegel		Lock	Verrou
52	9006.06.01	1	Riegelraste li.+Sensorhalt		Catch l.h. with holder	Cliquet gauche + support
53	933D616PA	32	Sechskantschraube	M6x16 DIN933-8.8 vz.	Hex. bolt	Vis 6 pans
54	9021DA6.4A	21	Scheibe	A 6.4 DIN9021 vz.	Washer	Rondelle
55	9001.95.03	36	Tensilockmutter	M 6 vz.	Tensi lock nut	Ecrou tensi
56	9998.01.24	1	Aufkleber	"Abdrehklappe"	Sticker	Autocollant
57	9998.01.23	1	Aufkleber	"Bodenklappenverstellu	Sticker	Autocollant
58	9998.01.67	1	Aufkleber	"Dosierradverriegelung"	Sticker	Autocollant
59	9998.01.18	1	Aufkleber	"Dosierradeinstellung"	Sticker	Autocollant
60	9006.06.20	1	Riegelraste			
61	9006.06.25	1	Flansch		Flange	Bride
62	9011.25.21	1	Düse f. Steigrohr			
63	7981DB3.56.5A	1	Linsen-Blechschaube	B 3,5x6,5 DIN7981 vz.		
64	9011.25.30	1	Einlauftrichter			
65	9001.52.08	1	Einlauftrichter			
66	9001.52.05	1	Einlauftrichter	Ø63,5	Disarge socket	Ecoulement
67	9011.25.20	1	Konusdüse			
68	933D825PA	5	Sechskantschraube	M8x25 DIN933-8.8 vz.	Hex. bolt	Vis 6 pans



**K**

Dosierung  
Metering unit  
Distribution

**MegaSeed**

Bild Ref. Fig.	Bestellnr. Part.-No. Référence	Stck Qty. Qte.	Bezeichnung	Technische Angaben Technical data Données techniques	Description	Désignation
69	125DA8.4A	5	Scheibe	A8,4 DIN125 vz.	Washer	Rondelle
70	985D8PA	5	Sechskantmutter	M8 DIN985-8 vz.	Hex.nut	Ecrou 6 pans
71	9031.27.01	1	Motorhalterung			
72	9031.11.49	1	Querriegel			
73-88	9018.39.01	1	ANTRIEBSMODUL KPL.		MAIN DRIVE CPL.	ENTRAINEMENT CPL.
73	9012.44.01	1	Motorträger			
74	9018.39.02	1	Zwischenwelle		Intermed. shaft	Arbre
75	9018.39.03	1	Riemenscheibe		Pulley	Poulie à moyeu
76	9018.39.04	1	Treibwelle		Input shaft	Arbre d'entree
77	9018.39.05	2	Flansch		Flange	Bride
78	9012.01.15	2	Rührwellenlager			
79	8404.26.26	2	O-Ring	88x6	O-seal	Joint torique
80	6885DA6630	1	Paßfeder	A 6x6x30 DIN6885	Key	Clavette
81	625D60022RS1	3	Rillenkugellager	6002 2RS1 DIN625	Ball bearing	Roulement à billes
82	933D625PA	4	Sechskantschraube	M6x25 DIN933- 8.8 vz.	Hex. bolt	Vis 6 pans
83	9001.95.03	4	Tensilockmutter	M 6 vz.	Tensi lock nut	Ecrou tensi
84	471D151	1	Sicherungsring	15x1 DIN471	Circlip	Circlip
85	933D580PA	2	Sechskantschraube	M5x80 DIN933-8.8 vz.	Hex.bolt	Vis 6 pans
86	985D5PA	2	Sechskantmutter	M5 DIN985-8 vz.	Hex. nut	Ecrou 6 pans
87	125DA5.3A	2	Scheibe	A 5,3 DIN125 vz.	Washer	Rondelle
88	9001.43.07	1	Rohrklappsplint	8x45 vz.	Lynch pin	Goupille
89	931D1065PA	8	Sechskantschraube	M10x65 DIN931- 8.8 vz.	Hex. bolt	Vis 6 pans
90	9021DA10.5A	14	Scheibe	A 10,5 DIN9021 vz.	Washer	Rondelle
91	127DA10A	8	Federring	A10 DIN127 vz.	Springwasher	Rondelle grower
92	934D10PA	9	Sechskantmutter	M10 DIN934-8 vz.	Hex. nut	Ecrou 6 pans
93	933D1030PA	2	Sechskantschraube	M10x30 DIN933-8.8 vz.	Hex. bolt	Vis 6 pans
94	985D10PA	2	Sechskantmutter	M10 DIN985-8 vz.	Hex. nut	Ecrou 6 pans
96-101	9012.11.01	1	ANSCHLUßWELLE		CONNECT. SHAFT C	ARBRE CPL.
96	934D10PA	1	Sechskantmutter	M10 DIN934-8 vz.	Hex. nut	Ecrou 6 pans
97	933D1025PA	1	Sechskantschraube	M10x25 DIN933-8.8 vz.	Hex. bolt	Vis 6 pans
100	9003.02.12	1	Gummischutzhülle		Rubber protection	Protection
101	9012.11.02	1	Anschlußwelle		Connecting shaft	Arbre



**K1**

Verteilereinheit  
Distributor head  
Tête de répartition

**MegaSeed**

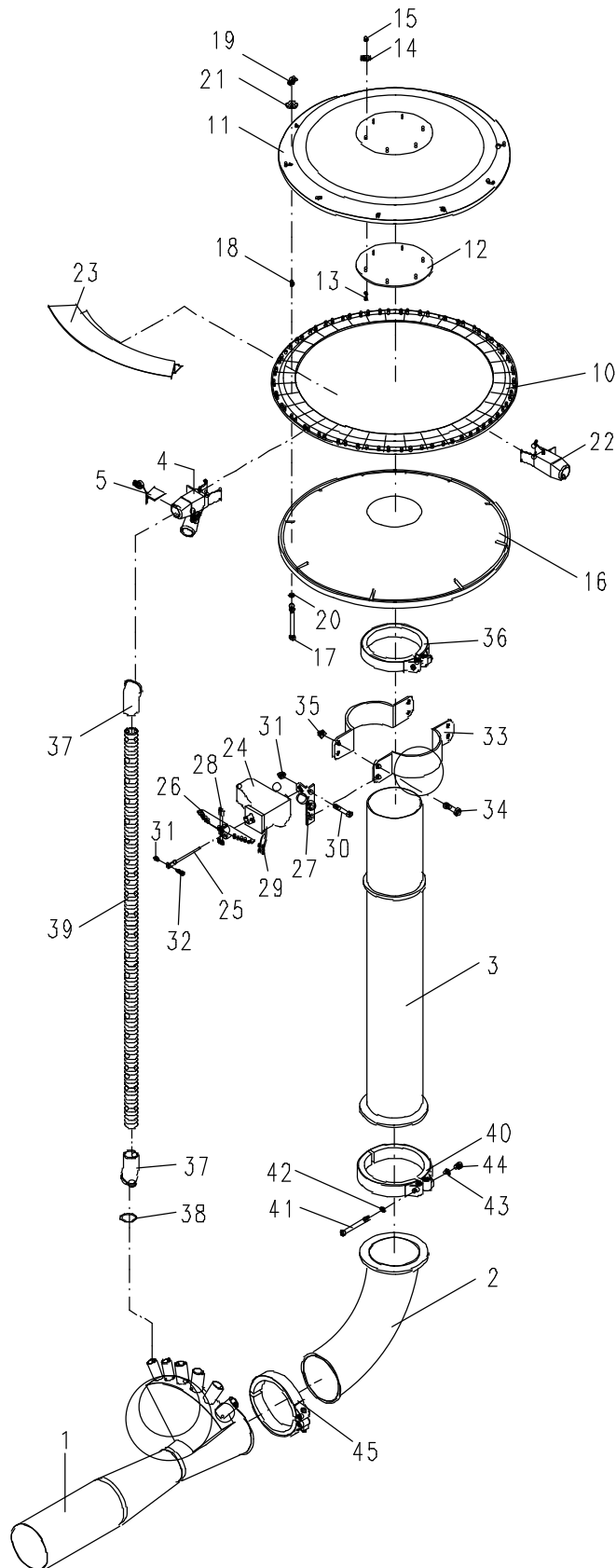



**K1**

Verteilereinheit  
Distributor head  
Tête de répartition

**MegaSeed 3001 S - 4501 K2**

Bild Ref. Fig.	Bestellnr. Part.-No. Référence	Stck Qty. Qte.	Bezeichnung	Technische Angaben Technical data Données techniques	Description	Désignation
	9032.22.01	1	VERTEILEREINHEIT KPL.	24 Ausl#ufe	DISTRIBUTOR HEAD	TETE DE REPARTITION
	9032.22.02	1	VERTEILEREINHEIT KPL.	32 Ausläufe	DISTRIBUTOR HEAD	TETE DE REPARTITION
	9032.22.03	1	VERTEILEREINHEIT KPL.	36 Ausläufe	DISTRIBUTOR HEAD	TETE DE REPARTITION
1	9011.07.06	1	Injektordüse, kurz		Venturi, short	Venturi, court
2	9011.10.01	1	Rohrbogen		Ellbow	Coude
3	9011.29.10	1	Steigrohr kurz		Pipe short	Tube court
4	9001.57.01	6	Verteilerauslauf mont.		2-Way outlet cpl.	Sorties cpl.
5	9001.57.02	6	Auslaßklappe		Flap	Linguet
10	9001.46.03	1	Verteilerkopfring	30-40	Distributor ring	Couronne de répa.
11	9001.97.02	1	Verteilerkopfdeckel		Distributor lid	Couvercle
12	9001.97.03	1	Verschleißplatte		Wear plate	Disque
13	963D416PA	6	Senkschraube	M4x16 DIN963-8.8 vz.	C sunk screw	Vis tête noyee
14	9001.97.04	6	Kotflügelscheibe		Washer	Rondelle
15	985D4PA	6	Sicherungsmutter	M4 DIN985-8 vz.	Hex.nut	Ecrou 6 pans
16	9001.46.05	1	Verteilerkopfboden		Distributor bottom	Carter de tête
17	933D580PA	10	Sechskantschraube	M5x80 DIN933-8.8 vz.	Hex.bolt	Vis 6 pans
18	6923D5RA	10	Sechskantmutter	M5.DIN6923-5 vz.	Hex. nut	Ecrou 6 pans
19	315D5RA	10	Flügelmutter	M5 DIN315-5 vz.	Wing nut	Ecrou à ailettes
20	9021DA5.3A	10	Scheibe	A 5,3 DIN9021 vz.	Washer	Rondelle
21	9001.46.21	10	Kotflügelscheibe		Washer	Rondelle
22	9001.57.10	18,26,30	Verteilerauslass, geschlossen		2-Way outlet closed	Sorties fermé
23	9011.27.13	2	Schutzhaube		Cover	Protection
24	9004.59.20	2	Elektrozylinder kpl.		Cylinder cpl.	Verin cpl.
25	9012.54.01	6	Feder		Spring	Ressort
26	9012.48.02	2	Federaufnahme, lang		Bracket	Support
27	9012.49.01	2	Halterung		Bracket	Support
28	9012.48.14	6	Seilklemme		Rope clamp	Serre fils
29	9012.16.12	4	Stossverbinder	0,5-1,0	Coupling	Rigide
30	933D640PA	4	Sechskantschraube	M6x40 DIN933-8.8 vz.	Hex. bolt	Vis 6 pans
31	980DV6PA	10	Sicherungsmutter	VM6 DIN980-8 vz.	Lock nut	Ecrou frein
32	933D612PA	6	Sechskantschraube	M6x12 DIN933-8.8 vz.	Hex. bolt	Vis 6 pans
33	9011.86.11	2	Schellenhälfte		Clip	Collier
34	933D1035PA	4	Sechskantschraube	M10x35 DIN933-8.8 vz	Hex. bolt	Vis 6 pans
35	985D10PA	4	Sechskantmutter	M10 DIN985-8 vz.	Hex.nut	Ecrou 6 pans
36	9001.46.06	1	Schlauchschelle	GBS 135/25	Hose clip	Collier
37	9001.46.07	12	Schlauchkupplung		Pipe coupling	Raccord



**K3**

Luftleitung  
Air pipe  
Conduit d'air

**Mega Seed**

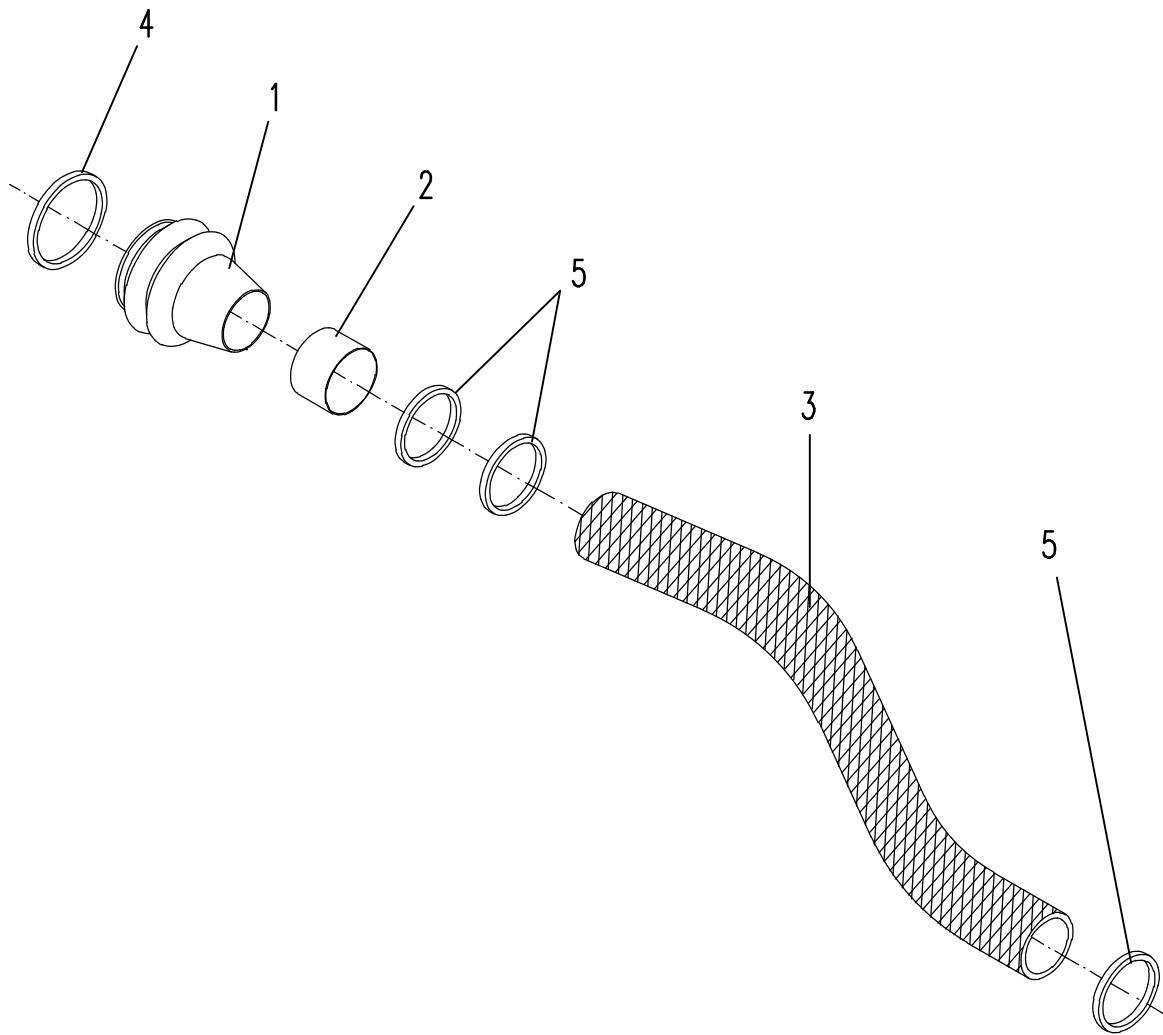



L

Gebälse  
Blower  
Turbine

MegaSeed

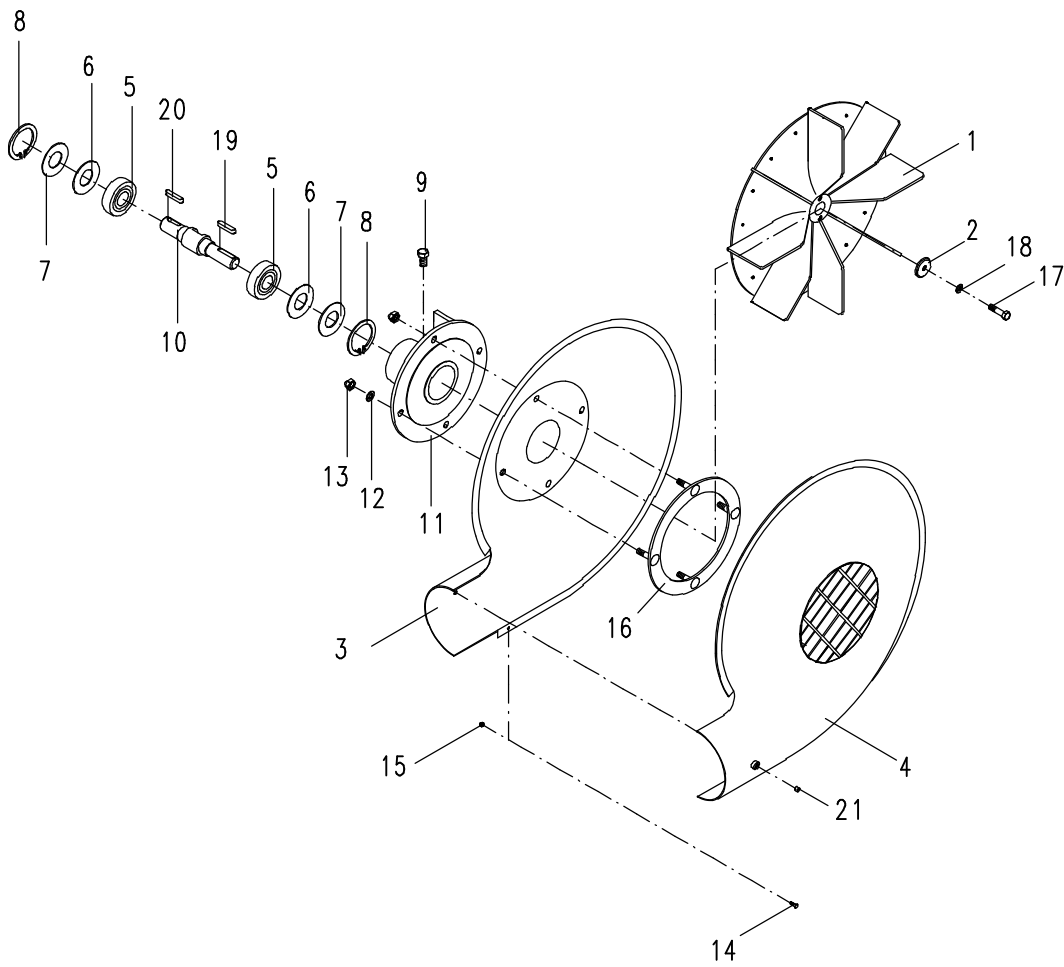



**L 4**

Hydraulik für Gebläseantrieb

Fan drive hydr. pipe

**MegaSeed 3001 S, 4001 K2, 4501 K2**

Hydraulique pour turbine

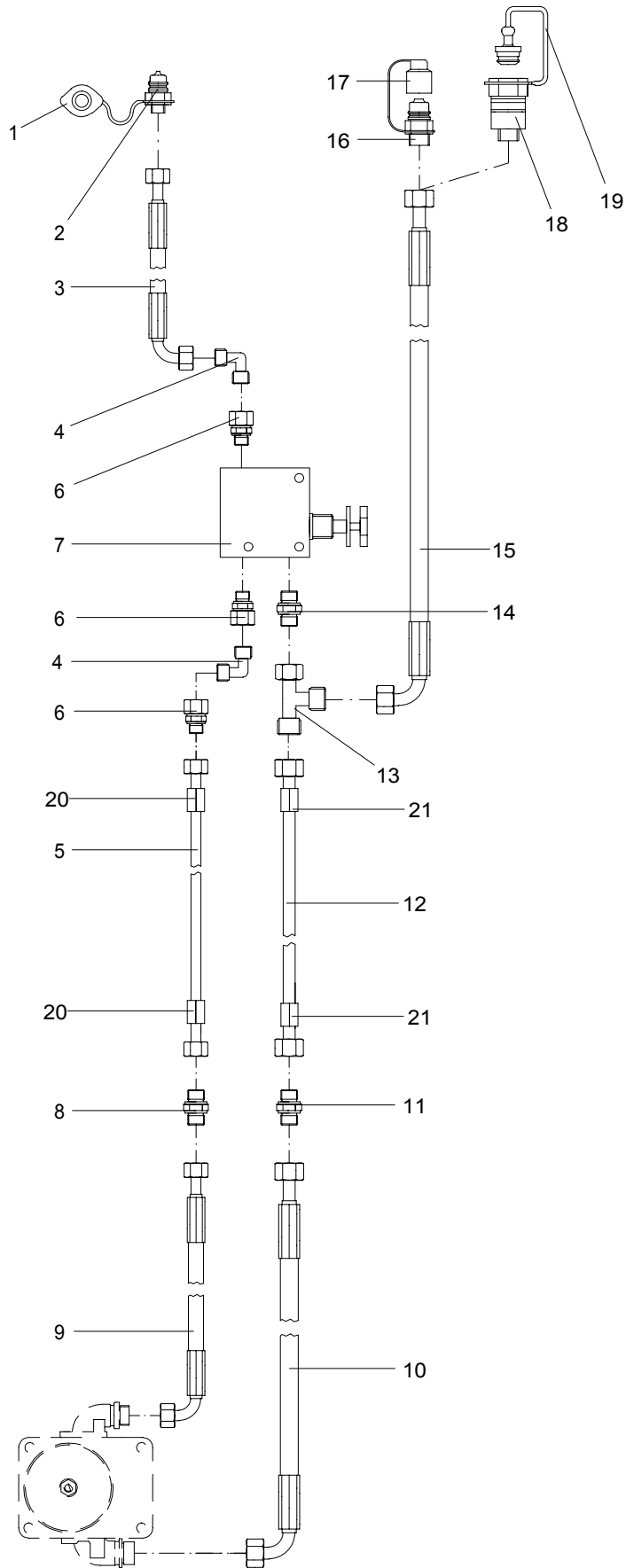

8173.06.04

**L4**Hydraulik für Gebläseantrieb  
Fan drive hydr. pipe  
Hydraulique pour turbine**MegaSeed 3001 S - 4501 K2**

Bild Ref. Fig.	Bestellnr. Part.-No. Référence	Stck Qty. Qte.	Bezeichnung	Technische Angaben Technical data Données techniques	Description	Désignation
1-21	8173.06.04	1	HYDRAULIK F. GEBLÄSEANTR.		HYDR. PIPE CPL.	HYDRAULIQUE CPL.
.	.	.	.	.	.	.
1	8132.05.01	1	Staubschutzkappe, rot		Dust cap red	Cache rouge
2	6251.28.08	1	SVK-Stecker	AG-M22X1,5-15 L	Coupling	Raccord
3	9032.12.22	1	Hydraulikschlauch	DN12 L=3500 AOL/AOL	Hydr. hose	Conduite flexible
4	8132.23.15	2	Winkelverschraubung	NW 15	Elbow coupling	Raccord coude
5	8172.06.05	1	Hydraulikrohr kpl.	L=1600 mm	Hydr.pipe cpl.	Tube cpl.
6	8132.23.14	3	Konusreduzierverschraub.	NW 15/12	Male stud coupling	Raccord
7	9001.60.73	1	Steuerblock		Governor valve	Valve hydr.
8	9001.60.62	1	Gerade Verschraubung	XG 15-PL	Male stud coupling	Raccord
9	9032.12.20	1	Hydraulikschlauch	DN13, L=600mm, AOL/AOL9	Hydr. hose	Conduite flexible
10	9032.12.21	1	Hydraulikschlauch	DN20, L=400mm, AOL/AOL9	Hydr. hose	Conduite flexible
11	8132.10.02	1	Gerade Verschraubung	E 12-L	Male stud coupling	Raccord
12	8172.14.01	1	Hydraulikrohr kpl.	L=1395 mm	Hydr.pipe cpl.	Tube cpl.
13	9001.60.93	1	Einstellb. L-Anschlußstutzen	EVL 22 PL	L-coupling	Raccord
14	9001.60.91	1	Gerade Einschraubverschraub.	GE 22 PLM 26x1,5	Male stud coupling	Raccord
15	9032.12.23	1	Hydraulikschlauch	DN20, L=3500mm, AOL/AOL	Hydr. hose	Conduite flexible
16	6251.28.10	1	SVK-Stecker	GE 22 LR 3/4 "	Coupling	Raccord
17	6251.28.11	1	Staubkappe		Dust cap	Cache
18	6251.28.12	1	SVK-Muffe	GE 22 LR 3/4 "	Dust cap	Cache
19	6251.28.13	1	Staubstecker		Dust plug	Prise
20	6251.33.03	2	Rohrschelle	SM 215 PP-LI	Pipe clamp	Collier
21	6251.33.04	2	Rohrschelle	SM 322 PP-LI	Pipe clamp	Collier
.	.	.	.	.	.	.
.	.	.	.	.	.	.
.	.	.	.	.	.	.
.	.	.	.	.	.	.
.	.	.	.	.	.	.
.	.	.	.	.	.	.
.	.	.	.	.	.	.
.	.	.	.	.	.	.
.	.	.	.	.	.	.
.	.	.	.	.	.	.
.	.	.	.	.	.	.
.	.	.	.	.	.	.
.	.	.	.	.	.	.
.	.	.	.	.	.	.
.	.	.	.	.	.	.
.	.	.	.	.	.	.
.	.	.	.	.	.	.
.	.	.	.	.	.	.

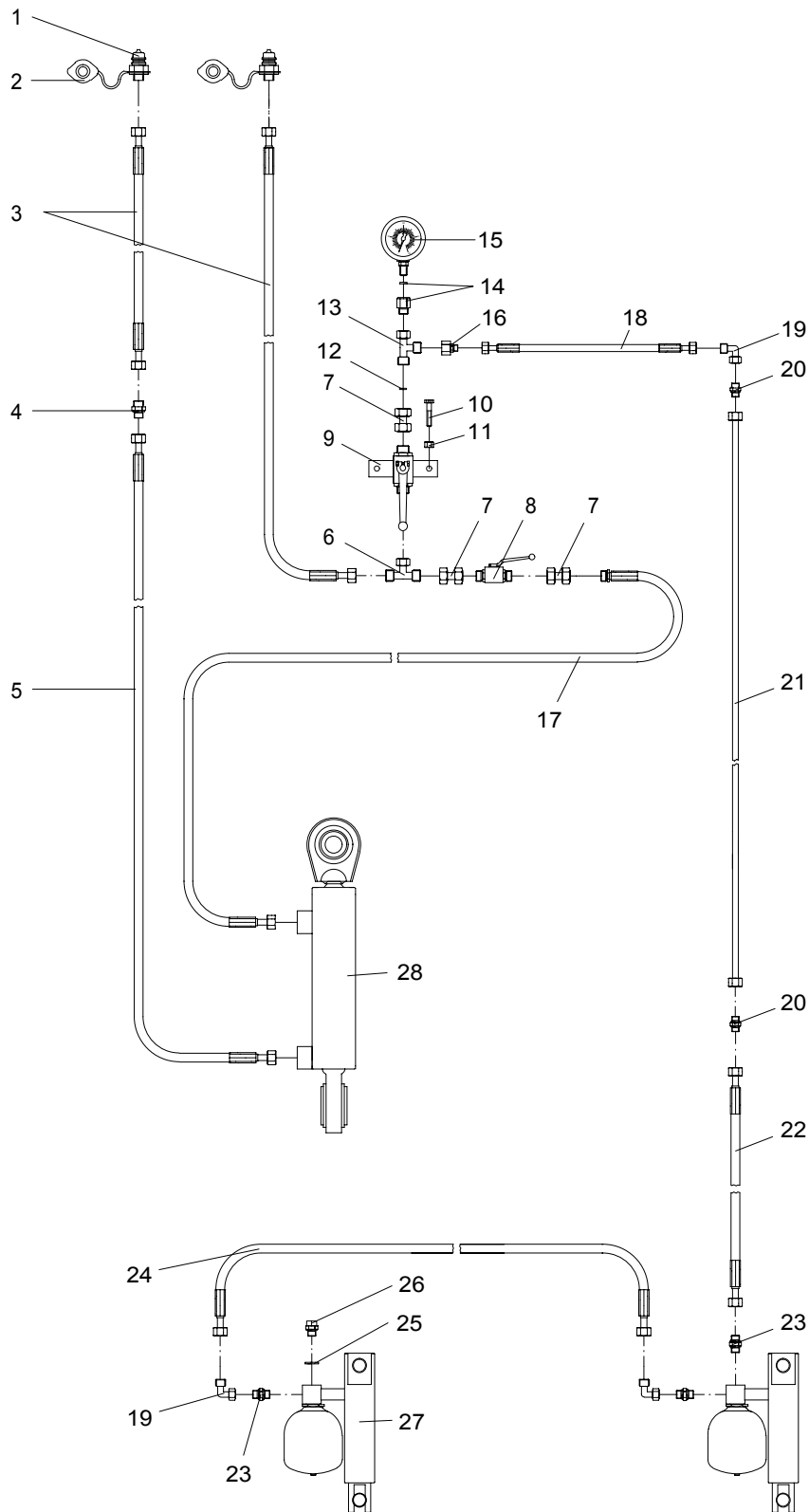

**M**

Hydraulik f. Schardruck, Vorwerkzeuge

**MegaSeed 3001 S**

Bild Ref. Fig.	Bestellnr. Part.-No. Référence	Stck Qty. Qte.	Bezeichnung	Technische Angaben Technical data Données techniques	Description	Désignation
1-28	8173.03.20	1	HYDR. F. SCHARDR.+VORWERK.		HYDR. PIPE CPL.	HYDRAULIQUE CPL.
.	.	.	.	.	.	.
1	8132.01.00	2	Kupplungsstecker	ISO 5675	Coupling	Raccord
2	8132.05.03	2	Staubschutzkappe, blau		Dust cap	Cache
3	6241.41.10	2	Höchstdruckschlauch	L=3500 mm	Hose	Conduite flexible
4	4716.52.13	1	Gerade Verschraubung	G 12-L	Male stud coupling	Raccord
5	4716.46.06	1	Höchstdruckschlauch	L=1000 mm	Hose	Conduite flexible
6	4723.02.02	1	Einstellb. T-Anschlußstutz.	EVT 12-L	Adj. T-coupling	Raccord
7	4716.53.05	3	Hydraulikrohr kpl.	L=40 mm	Hydr.pipe cpl.	Tube cpl.
8	4716.46.05	1	HD-Blockkugelhahn	NW-10	Ball valve	Robinet
9	8173.10.01	1	Blockkugelhahn m.Platte		Ball valve with plate	Robinet avec plaquette
10	933D820PA	2	Sechskantschraube	M8x20 DIN933-8.8 vz.	Hex. bolt	Vis 6 pans
11	985D8PA	2	Sechskantmutter	M8 DIN985-8 vz.	Hex.nut	Ecrou 6 pans
12	8132.06.01	1	Drosselscheibe	Ø2	Restrictive washer	Etranglement
13	4723.02.05	1	Einstellb. L-Anschlußst.	EVL-12 L	L-coupling	Raccord
14	2614.71.02	1	Manometerverschr.	MAV 12-LR	Screw joint	Raccord
15	2614.71.03	1	Manometer	O-400 R 1/4"	Manometer	Manomètre
16	7406.39.01	1	Konus-Reduzieranschl.	KOR 12/8-PL	Hydr. fitting	Raccord
17	6436.07.04	1	Höchstdruckschlauch	L=700 mm	Hose	Conduite flexible
18	9004.19.09	1	Hydraulikschlauch	A0/A0 DN6 L=500 mm	Hydr. hose	Conduite flexible
19	9004.17.08	1	Winkelanschlußstutzen		Elbow coupling	Raccord coude
20	9001.60.24	2	Gerade Verschraubung	G 8-L	Male stud coupling	Raccord
21	9004.50.00	1	Hydraulikrohr kpl.	L=1968 mm	Hydr.pipe cpl.	Tube cpl.
22	9001.60.22	1	Hydraulikschlauch	DN6, L=1600mm, A0/A0	Hydr. hose	Conduite flexible
23	8153.01.06	3	Gerade Einschraubverschr.	GE 8-PLM	Male stud coupling	Raccord
24	8132.22.01	1	Hydraulikschlauch	L=1000 mm, DN 6 A0/A0	Hydr. hose	Conduite flexible
25	7603DA12155	1	Dichtring	A 12x15,5x1,5 DIN7603	Seal ring	Joint
26	910D1215V	1	Verschußschraube	M12x1,5 DIN910-5.8	Hexagon head plug	Bouchon fileté
.	.	.	.	.	.	.
.	.	.	.	.	.	.
.	.	.	.	.	.	.
.	.	.	.	.	.	.
.	.	.	.	.	.	.
.	.	.	.	.	.	.
.	.	.	.	.	.	.
.	.	.	.	.	.	.
.	.	.	.	.	.	.
.	.	.	.	.	.	.
.	.	.	.	.	.	.

**M1**

Hydraulik für Schardruck

Hydr. for coulter pressure **MegaSeed 4001 K2 - 6002 K2 Br./Serie 0-3**

Hydraulique pour pression des socs

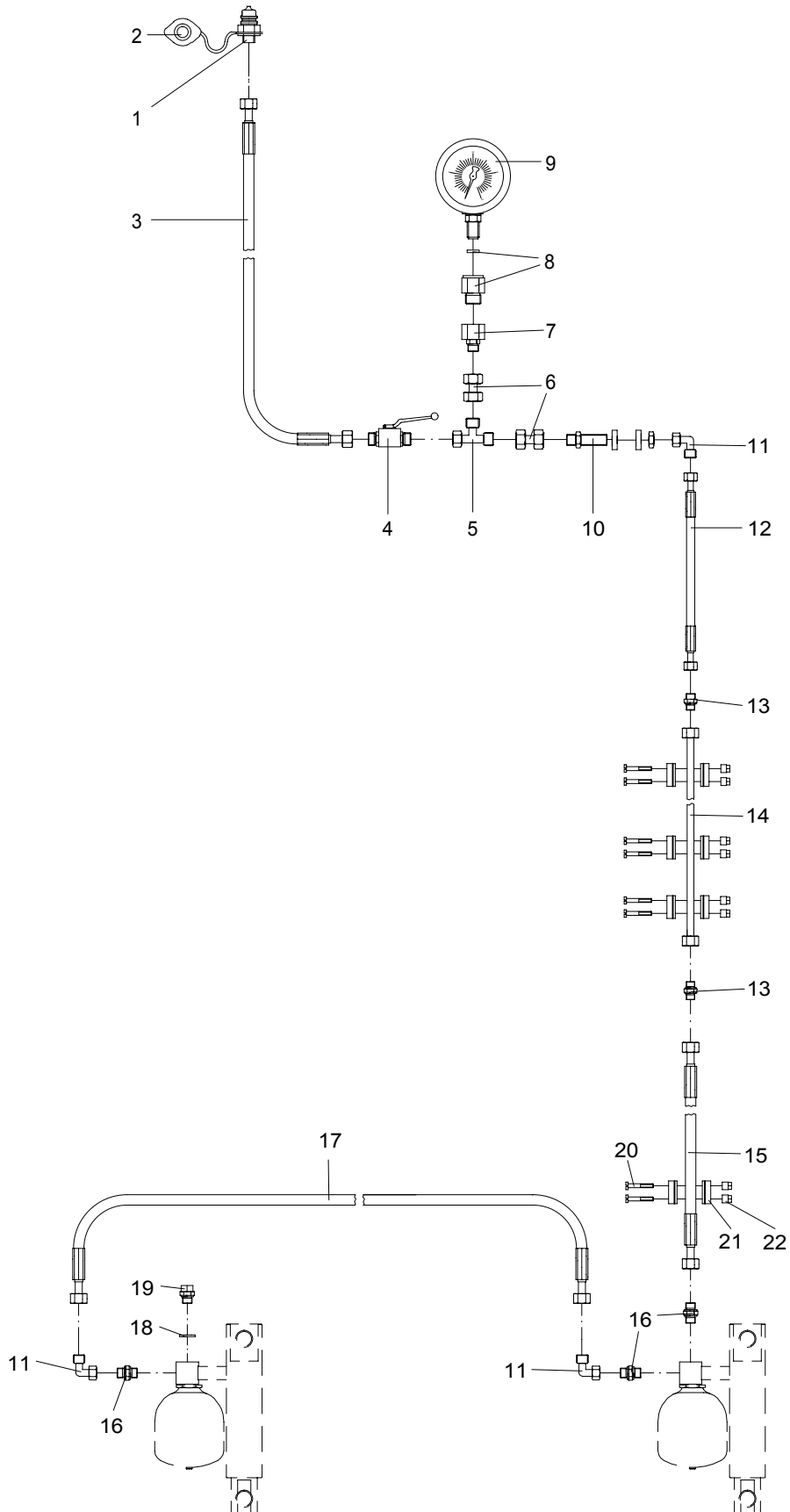

8173.07.01



**M1**

Hydraulik für Schardruck  
Hydr.pipe for coulter pressure  
Hydraulique pour pression des socs

**MegaSeed 4001 K2 - 6002 K2 Br./Serie 0 - 3**

Bild Ref. Fig.	Bestellnr. Part.-No. Référence	Stck Qty. Qte.	Bezeichnung	Technische Angaben Technical data Données techniques	Description	Désignation
1-22	8173.07.01	1	HYDRAULIK F.SCHARDRUCK		HYDR.PIPE CPL.	HYDRAULIQUE CPL.
1	8132.01.00	1	Kupplungsstecker	ISO 5675	Coupling	Raccord
2	8132.05.03	1	Staubschutzkappe, blau		Dust cap	Cache
3	9001.60.46	1	Hydraulikschlauch	DN6 L=3500 A0/A0	Hydr. hose	Conduite flexible
4	8151.15.06	1	Kugelhahn	K-KHV 8L/NW 6	Ball valve	
5	9004.19.10	1	Einstell. Anschlußstutz.	EVL8-PL	Coupling	Raccord
6	9004.60.03	2	Doppelverbinder	GVO 8-L	Coupling	Tuyau rigide
7	7406.39.01	1	Konus-Reduzieranschl.	KOR 12/8-PL	Hydr. fitting	Raccord
8	2614.71.02	1	Manometerverschr.	MAV 12-LR	Screw joint	Raccord
9	2614.71.03	1	Manometer	O-400 R 1/4"	Manometer	Manomètre
10	9001.60.21	1	Gerade Schottverschr.		Nut coupling	Raccord
11	9004.17.08	1	Winkelanschlußstutzen		Elbow coupling	Raccord coude
12	9004.19.09	1	Hydraulikschlauch	A0/AO DN6 L=500 mm	Hydr. hose	Conduite flexible
13	9001.60.24	2	Gerade Verschraubung	G 8-L	Male stud coupling	Raccord
14	8172.11.01	1	Hydraulikrohr kpl.	L=1950 mm	Hydr.pipe cpl.	Tube cpl.
15	9001.60.22	1	Hydraulikschlauch	DN6, L=1600mm, A0/A0	Hydr. hose	Conduite flexible
16	8153.01.06	3	Gerade Einschraubverschr.	GE 8-PLM	Male stud coupling	Raccord
17	8132.22.01	1	Hydraulikschlauch	L=1000 mm, DN 6 A0/A0	Hydr. hose	Conduite flexible
18	7603DA1215515CU	1	Dichtring	A 12x15,5x1,5 DIN7603	Seal ring	Joint
19	910D1215V	1	Verschlussschraube	M12x1,5 DIN910-5.8	Hexagon head plug	Bouchon fileté
20	84D625W	8	Zylinderschraube	M6x25 DIN84-4.8	Spline screw	Vis cylindrique
21	4753.56.02	4	Schelle kpl.		Clip cpl.	Collier cpl.
22	4753.56.05	8	Schienenmutter		Nut	Ecrou
.	.	.	.	.	.	.
.	.	.	.	.	.	.
.	.	.	.	.	.	.
.	.	.	.	.	.	.
.	.	.	.	.	.	.
.	.	.	.	.	.	.
.	.	.	.	.	.	.
.	.	.	.	.	.	.
.	.	.	.	.	.	.
.	.	.	.	.	.	.
.	.	.	.	.	.	.
.	.	.	.	.	.	.
.	.	.	.	.	.	.

N

Artemis II  
Artemis II  
Artemis II

MegaSeed

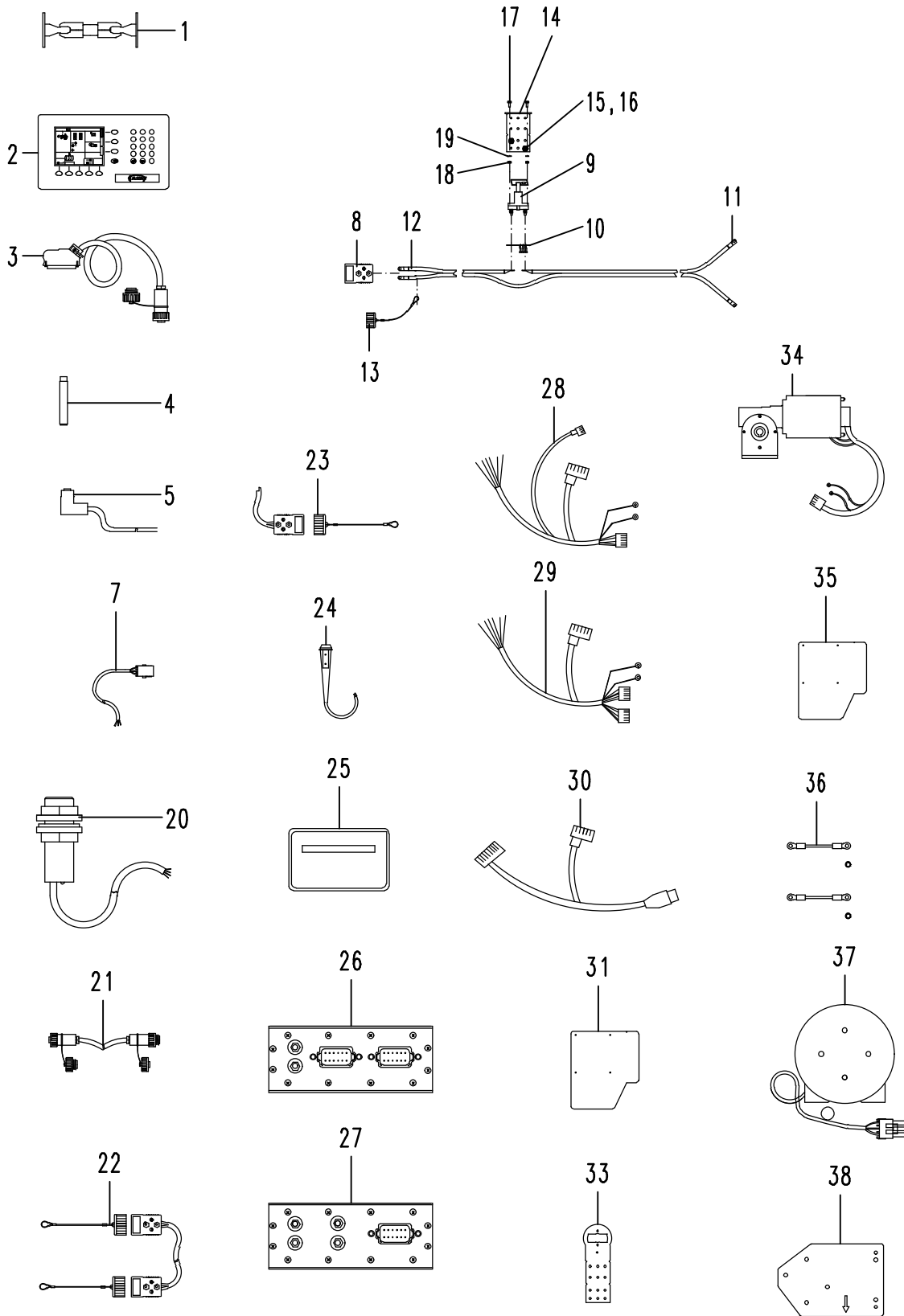

9012.70.02

9012.70.01



**N**

Artemis II  
Artemis II  
Artemis II

**MegaSeed**

Bild Ref. Fig.	Bestellnr. Part.-No. Référence	Stck Qty. Qte.	Bezeichnung	Technische Angaben Technical data Données techniques	Description	Désignation
1-38	9012.70.01	1	ARTEMIS II +GERÄTERADAR			
1-36	9012.70.02	1	ARTEMIS II +SCHLEPP.-RADAR			
.						
1	9012.45.14	1	Stativhalter			
2	9012.63.04	1	Display	Pro S 8000		
3	9012.63.06	1	Anschlußsteuerung II			
4	9012.45.42	4	Sensor	N.O.		
5	9012.45.43	4	Kabeldose			
.						
7	9012.45.15	1	Spornradkabel			
.						
8-19	9012.55.01	1	VERSORG.-KABELBAUM KPL.			
8	9012.51.03	1	Steckverbinder	80 A		
9	9012.45.70	1	Stromschalter			
10	9012.58.30	1	Sicherung			
11	9012.55.10	4	Kerbkabelschuh			
12	9012.51.02	1	Kabel	2x16		
13	9012.51.04	1	Schutzkappe		Protecting cap	Couvercle de protection
14	9012.58.20	1	Blech f. Hauptschalter			
15	933D640PA	4	Sechskantschraube	M6x40 DIN933-8.8 vz.	Hex. bolt	Vis 6 pans
16	980DV6PA	4	Sicherungsmutter	VM6 DIN980-8 vz.	Lock nut	Ecrou frein
17	933D1020PA	1	Sechskantschraube	M10x20 DIN933-8.8 vz.	Hex. bolt	Vis 6 pans
18	934D10PA	1	Sechskantmutter	M10 DIN934-8 vz.	Hex. nut	Ecrou 6 pans
19	126D11A	1	Scheibe	11 DIN126 vz.	Washer	Rondelle
.						
20	9012.45.60	1	Füllstandssensor			
21	9012.45.90	1	Verbindung	CA 6		
22	9012.51.01	1	Kabel	80 A		
23	9012.67.10	1	Anschlußkabel	80 A		
24	9012.45.12	1	Drucktaster			
25	9012.71.00	2	Verteilerdose			
26	9012.62.05	1	Rechner	CAN HBM		
27	9012.62.06	1	Motorcontrol	MCM		
28	9012.62.10	1	Kabelbaum	HBM		
29	9012.62.09	1	Kabelbaum	MCM		
30	9012.62.08	1	Kabelbaum Steuerung			
31	9012.70.12	1	Schutzblech, rechts		Cover r.h.	Tôle de protection droit
.						





Säeinheit kpl.  
Benennung  
Benennung

# MegaSeed 3001 S

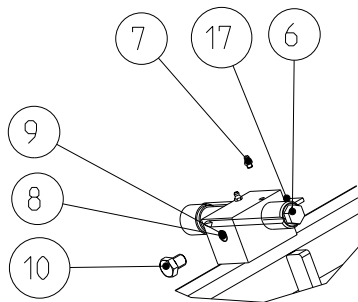
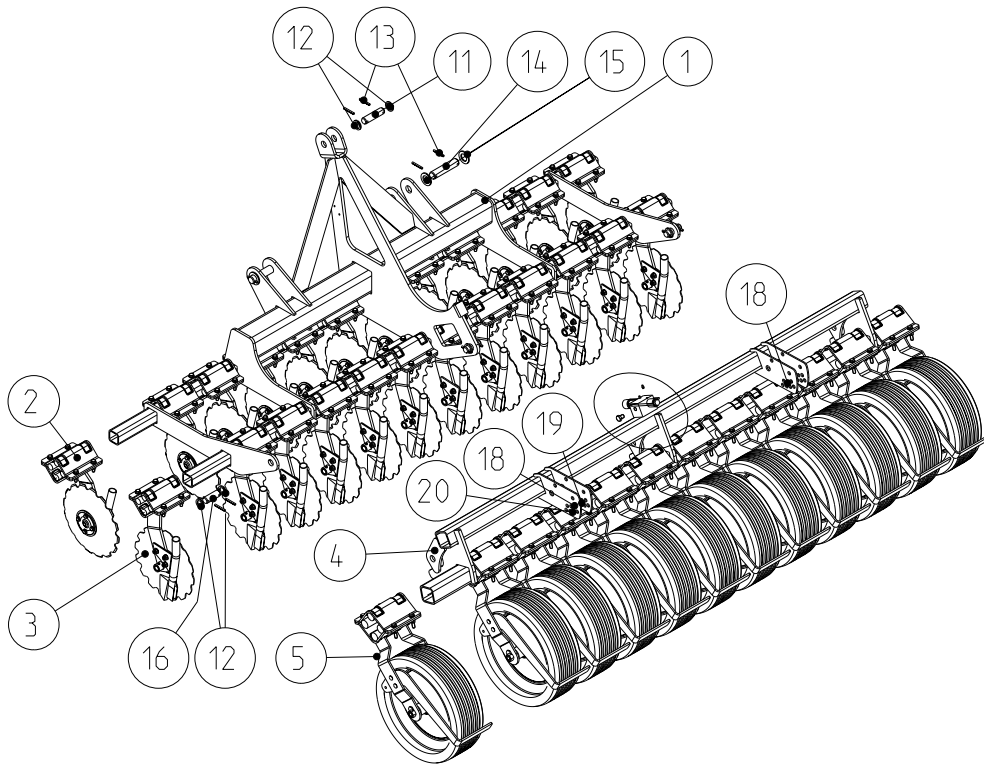



01

Säeinheit kpl.  
#  
#

MegaSeed 4001 K2, 4501 K2

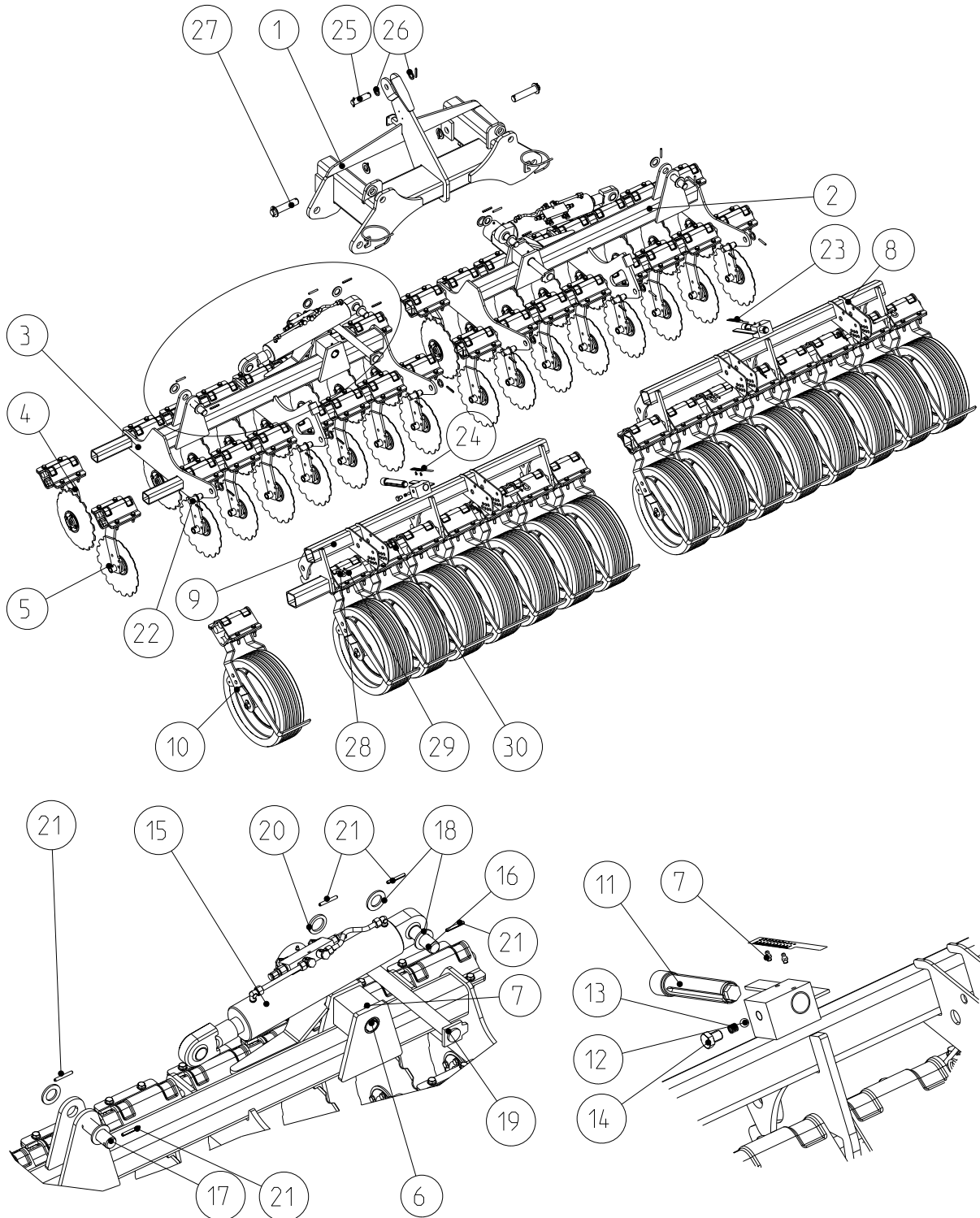



**O1**

Säeinheit kpl.

###  
###

**MegaSeed 4001 K2, 4501 K2**

Bild Ref. Fig.	Bestellnr. Part.-No. Référence	Stck Qty. Qte.	Bezeichnung	Technische Angaben Technical data Données techniques	Description	Désignation
1-25	9031.03.51	1	SAEINHEIT KPL.	4,0 m		
1-25	9031.03.53	1	SAEINHEIT KPL.	4,5 m		
1	9031.03.01	1	Schwenkrahmen			
2	9031.03.30	1	Tragrahmen, rechts	4,0 m	Beam r.h.	Bâti droit
2	9031.03.60	1	Tragrahmen, rechts	4,5 m	Beam r.h.	Bâti droit
3	9031.03.31	1	Tragrahmen, links	4,0 m	Beam l.h.	Bâti gauche
3	9031.03.61	1	Tragrahmen, links	4,5 m	Beam l.h.	Bâti gauche
4	9031.01.01	16,18	SAEINHEIT LINKS MONT.			
5	9031.01.02	16,18	SAEINHEIT RECHTS MONT			
6	4757.38.10	4	Stahleinspannbuchse	E 49x40x55 F3	Bush	Bague
7	4716.38.00	8	Schmiernippel	H1 8x1 KX-1	Grease nipple	Graisser
8	9031.03.80	1	Druckrollenrahmen, rechts	4,0 m	Beam r.h.	Bâti droit
8	9031.03.85	1	Druckrollenrahmen, rechts	4,5 m	Beam r.h.	Bâti droit
9	9031.03.81	1	Druckrollenrahmen, links	4,0 m	Beam l.h.	Bâti gauche
9	9031.03.86	1	Druckrollenrahmen, links	4,5 m	Beam l.h.	Bâti gauche
10	9031.01.20	16,18	DRUCKROLLENARM KPL.			
11	4780.71.04	2	Verkantungsspindel		Adjusting spindle	Manivelle
12	4716.36.00	2	Kugel	RB-14/III D14 ID-3	Ball	Bille
13	4716.12.00	2	Druckfeder	DF-80	Compression spring	Ressort
14	961D161520P	2	Sechskantschraube	M16x1,5x20 DIN961-8.8	Hex. bolt	Vis 6 pans
15	8172.04.02	2	KLAPPZYLINDER KPL.		FOLDING CYLINDER	VERIN REPLIAGE CPL.
16	1000.13.09	2	Bolzen	Ø35 mm	Pin	Axe
17	1000.13.06	2	Bolzen	Ø35 mm		
18	126D36A	12	Scheibe	36 DIN126 vz.		
19	1000.11.02	2	Bolzen	Ø40 mm	Pin	Axe
20	1441D41A	2	Scheibe	41 DIN1441 vz.	Washer	Rondelle
21	1481D860A	28	Spannstift	8x60 DIN1481 vz.	Dowel pin	Goupille serrage
22	1000.10.02	6	Bolzen	Ø30 mm	Pin	Axe
23	9998.09.01	1	Aufkleber	"Skala Sätiefeneinstell.recht	Sticker	Autocollant
24	9998.09.02	1	Aufkleber	"Skala Sätiefeneinstell.links"	Sticker	Autocollant
25	1000.16.01	1	Bolzen	Ø30 mm	Pin	Axe
26	1441D31A	14	Scheibe	31 DIN1441 vz.	Washer	Rondelle
27	1000.13.11	2	Bolzen	Ø35 mm	Pin	Axe
28	6248.14.00	4	Steckbolzen	Ø16 mm	Pin	Axe
29	1481D645	4	Spannstift	6x45 DIN1481	Dowel pin	Goupille serrage
30	4716.35.00	4	Federsteckstock	BTB-4	R-clip	Goupille beta

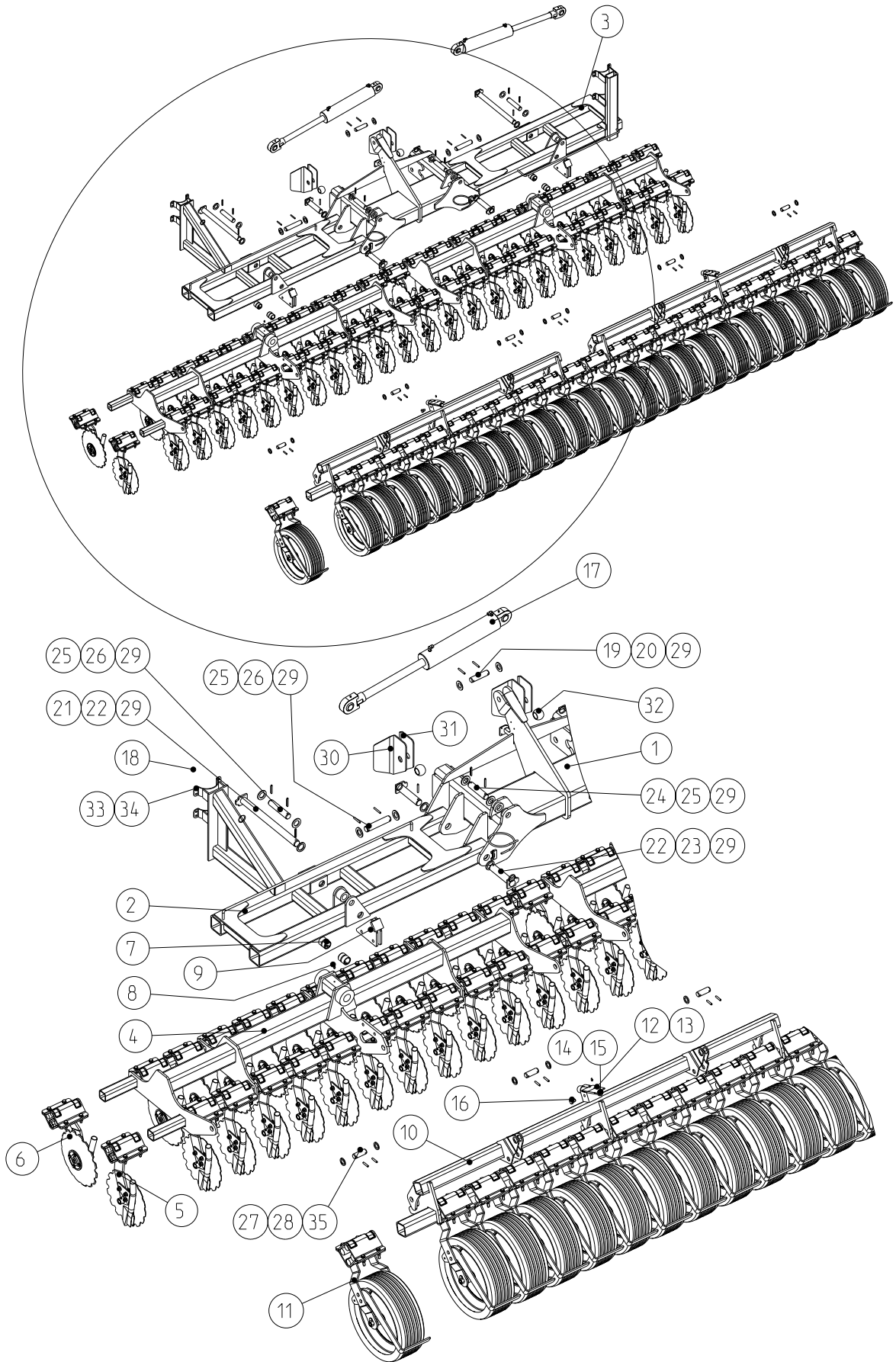



**O4**

Säeinheit kpl.

###

###

**MegaSeed 6002 K2 Br./Serie 3**

Bild Ref. Fig.	Bestellnr. Part.-No. Référence	Stck Qty. Qte.	Bezeichnung	Technische Angaben Technical data Données techniques	Description	Désignation
1	9032.60.30	1	Schwenkrahmen			
2	9032.60.20	1	Klapprahmen, links			
3	9032.60.19	1	Klapprahmen, rechts			
4	9032.60.12	2	Särahmen			
5	9031.01.02	24	SAESEGMEN RECHTS			
6	9031.01.01	24	SAESEGMEN LINKS			
7	4757.38.10	4	Stahleinspannbuchse	E 49x40x55 F3	Bush	Bague
8	4716.38.00	4	Schmiernippel	H1 8x1 KX-1	Grease nipple	Graisseur
9	9032.60.98	2	Verlängerung		Extension	Extension
10	9031.03.89	2	Druckrollenrahmen			
11	9031.01.20	24	DRUCKROLLENARM KPL.			
12	4780.71.04	2	Verkantungsspindel		Adjusting spindle	Manivelle
13	4716.38.00	4	Schmiernippel	H1 8x1 KX-1	Grease nipple	Graisseur
14	4716.36.00	2	Kugel	RB-14/III D14 ID-3	Ball	Bille
15	4716.12.00	2	Druckfeder	DF-80	Compression spring	Ressort
16	961D161520P	2	Sechskantschraube	M16x1,5x20 DIN961-8.8	Hex. bolt	Vis 6 pans
17	8172.04.15	2	ZYLINDER KPL.	90/45/405/730	CYLINDER CPL.	VERIN CPL.
18	9011.86.11	4	Schellenhälfte		Clip	Collier
19	1000.16.05	1	Bolzen	Ø30 mm	Pin	Axe
20	1441D31A	14	Scheibe	31 DIN1441 vz.	Washer	Rondelle
21	1000.03.20	2	Bolzen	Ø40 mm	Pin	Axe
22	1441D41A	6	Scheibe	41 DIN1441 vz.	Washer	Rondelle
23	1000.03.10	4	Bolzen	Ø40 mm	Pin	Axe
24	1000.13.08	2	Bolzen	Ø35 mm	Pin	Axe
25	126D36	14	Scheibe	36 DIN126	Washer	Rondelle
26	1000.13.11	4	Bolzen	Ø35 mm	Pin	Axe
27	1000.10.02	6	Bolzen	Ø30 mm	Pin	Axe
28	1441D31A	12	Scheibe	31 DIN1441 vz.	Washer	Rondelle
29	1481D860A	1	Spannstift	8x60 DIN1481 vz.	Dowel pin	Goupille serrage
30	9032.60.85	2	UL-Fangblech, links		Catch plate l.h.	Crochet gauche
31	9032.60.86	2	UL-Fangblech, rechts		Catch plate r.h.	Crochet droit
32	9031.19.51	2	Kugelhülse	Kat.3	Sleeve	Douille



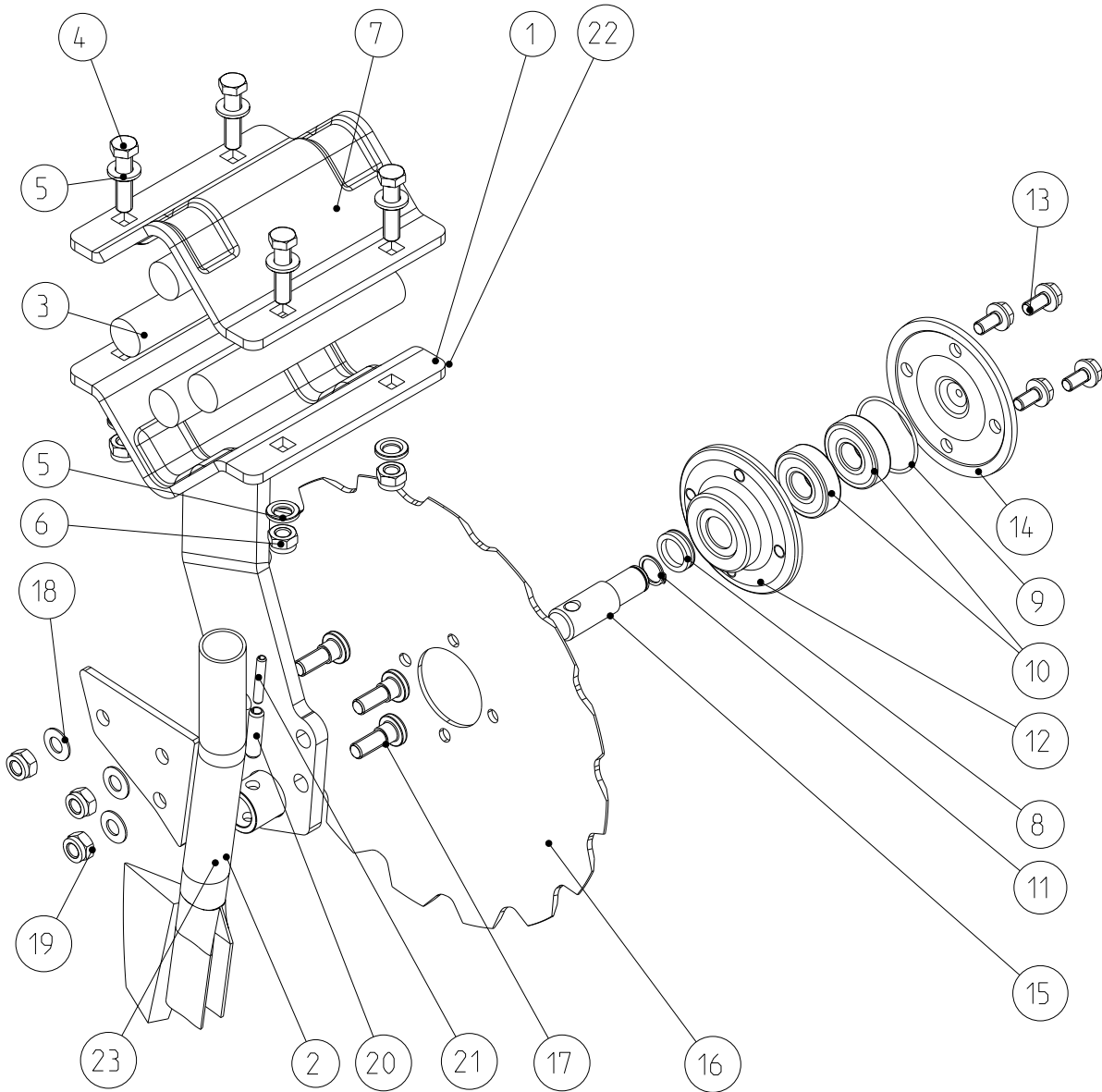



**O2**

Säsegment

###  
###

**MegaSeed**

Bild Ref. Fig.	Bestellnr. Part.-No. Référence	Stck Qty. Qte.	Bezeichnung	Technische Angaben Technical data Données techniques	Description	Désignation
1-21	9031.01.01	1	SAESEMENT LINKS			
3-23	9031.01.02	1	SAESEMENT RECHTS			
.						
1	9031.01.03	1	Tragarm, links			
2	9008.61.02	1	Särohr, vorne		Seed pipe front	Tube de descente avant
3	9031.01.18	4	Gummielment	Ø30x190		
4	933D1250PA	4	Sechskantschraube	M12x50 DIN933-8.8 vz.	Hex.bolt	Vis 6 pans
5	6916D13A	8	Scheibe	13 DIN 6916 vz.	Washer	Rondelle
6	985D12PA	4	Sechskantmutter	M12 DIN985-8 vz.	Hex. nut	Ecrou 6 pans
7	9031.01.07	1	Lagerblech			
.						
8-15	9008.56.01	1	SCHEIBENLAGERUNG		BEARING CPL.	PALIER CPL.
8	9008.03.13	1	Dichtring	V-Seal TWVA 00250	Seal ring	Joint
9	8404.26.25	1	O-Ring	55x2,5	O-seal	Joint torique
10	625D63042RS1	2	Rillenkugellager	6304 2RS1 DIN625	Ball bearing	Roulement à billes
11	471D201.2	1	Sicherungsring	20x1,2 DIN471	Circlip	Circlip
12	9008.56.10	1	Lagergehäuse		Bearing housing	Braquette
13	8426.13.09	4	Verbus-Ripp 6ktschr.	M10x20-100	Bolt	Vis
14	9008.56.12	1	Lagerdeckel		Lid	Couvercle
15	9008.56.11	1	Scheibenachse		Axle	Axe
.						
16	9008.55.10	1	Räumscheibe gezackt		Disc notched	Rondelle crènelé
17	6330.00.04	3	Riffelbolzen	M12x1,5x36	Wheel stud	Boulon cannelé
18	2093DA25	3	Tellerfeder		Cup spring	Ressort bellavil
19	985D1215PA	3	Sechskantmutter	M12x1,5 DIN985-8 vz.	Hex.nut	Ecrou 6 pans
20	1481D1040A	1	Spannstift	10x40 DIN1481 vz.	Dowel pin	Goupille serrage
21	1481D640A	1	Spannstift	6x40 DIN1481 vz.	Dowel pin	Goupille serrage
22	9031.01.04	1	Tragarm, rechts			
23	9008.61.01	1	Särohr, hinten		Seed pipe rear	Tube de descente arrière
.						
.						
.						
.						
.						
.						
.						
.						
.						

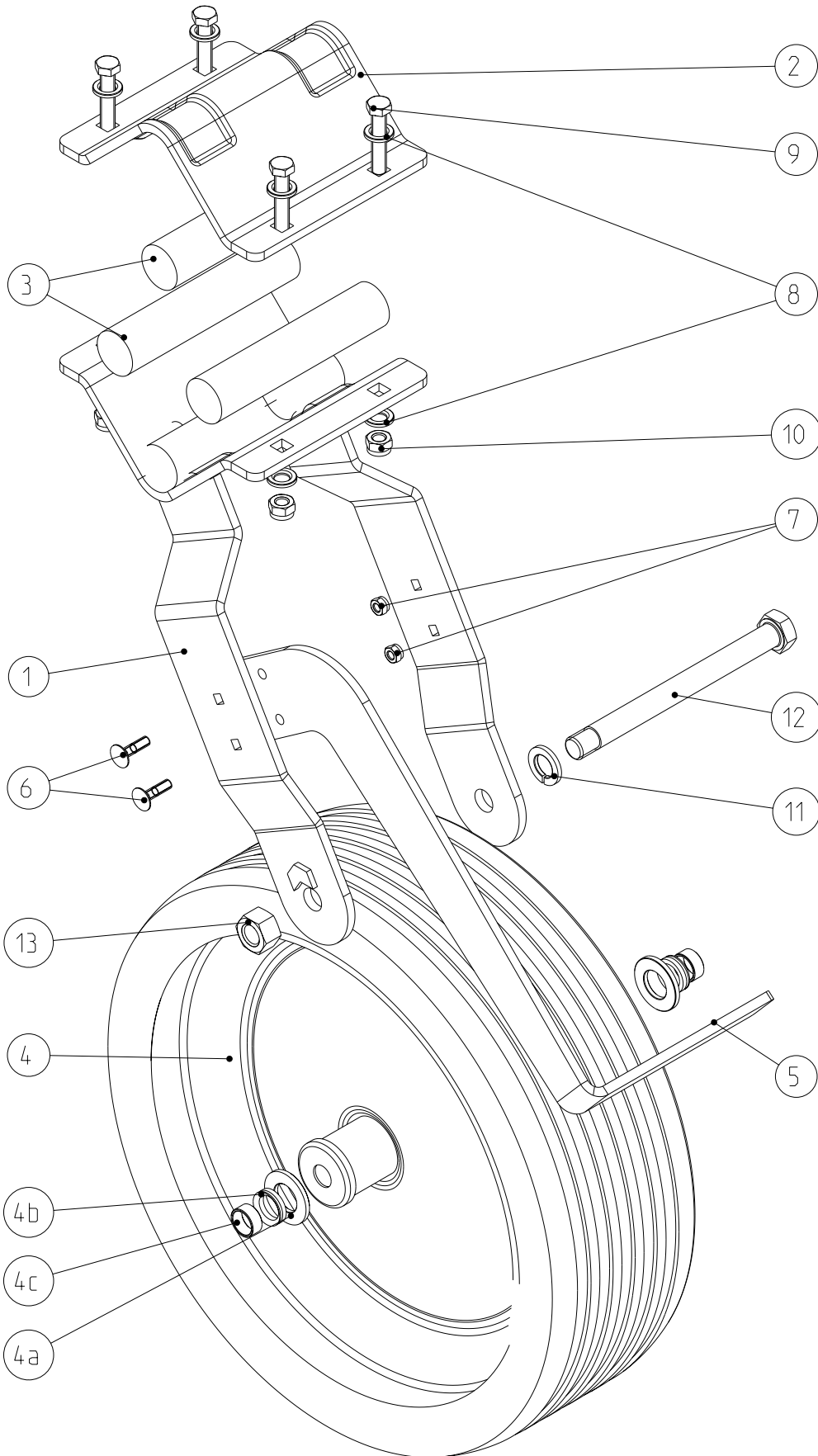



03

Druckrollenarm

###

###

MegaSeed

Bild Ref. Fig.	Bestellnr. Part.-No. Référence	Stck Qty. Qte.	Bezeichnung	Technische Angaben Technical data Données techniques	Description	Désignation
1-13	9031.01.20	1	DRUCKROLLENARM KPL.			
.						
1	9031.01.08	1	Druckrollenarm			
2	9031.01.10	1	Lagerblech		Plate	Tôle
3	9031.01.19	4	Gummi-Element		Rubber element	Élément silenc
.						
4-4c	9008.46.01	1	FARMFLEXRAD KPL.	Ø500x175		
4a	6436.30.05	2	Dichtscheibe	DW-9	Sealing washer	Joint
4b	9008.03.13	2	Dichtring	V-Seal TWVA 00250	Seal ring	Joint
4c	9008.46.21	2	Distanzrohr, kurz		Spacer	Entretoise
.						
5	9031.18.12	1	Abstreifer		Scraper	Décrottoir
6	603D830PA	2	Flachrundsraube	M8x30 DIN603-8.8 vz.	Bolt	Vis
7	985D8PA	2	Sechskantmutter	M8 DIN985-8 vz.	Hex.nut	Ecrou 6 pans
8	6916D13A	8	Scheibe	13 DIN 6916 vz.	Washer	Rondelle
9	933D1260PA	4	Sechskantschraube	M12x60 DIN933-8.8 vz.	Hex. bolt	Vis 6 pans
10	985D12PA	4	Sechskantmutter	M12 DIN985-8 vz.	Hex. nut	Ecrou 6 pans
11	127DB20A	1	Federring	B20 DIN127 vz.	Springwasher	Rondelle grower
12	9008.50.22	1	Sonderschraube	M20x225 - 10.9	Bolt	Vis
13	934D20PA	1	Sechskantmutter	M20 DIN934-8 vz.	Hex. nut	Ecrou 6 pans
.						
.						
.						
.						
.						
.						
.						
.						
.						
.						
.						
.						
.						
.						
.						
.						
.						
.						
.						
.						

P

Striegelschiene  
Harrow rail  
Plaque de herse

MegaSeed 3001S

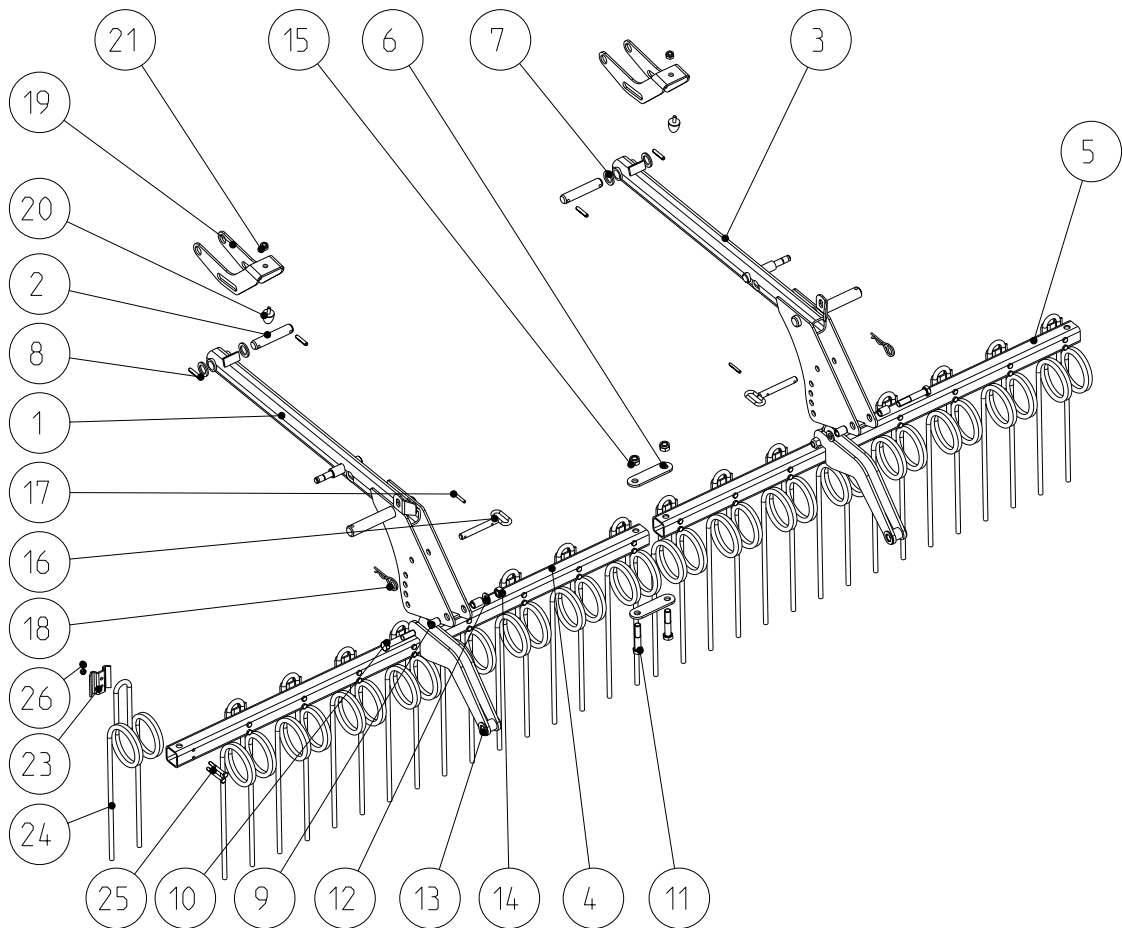

**P**

Striegelschiene  
Harrow rail  
Plaque de herse

**MegaSeed 3001 S**

Bild Ref. Fig.	Bestellnr. Part.-No. Référence	Stck Qty. Qte.	Bezeichnung	Technische Angaben Technical data Données techniques	Description	Désignation
	9032.19.01	1	STRIEGELSCHIENE	3,0m	HARROW RAIL	PLAQUE DE HERSE
1	9032.16.01	1	Striegelhalter, innen links		Bracket l.h.	Support gauche
2	1000.05.04	2	Bolzen		Pin	Axe
3	9032.16.02	1	Striegelhalter, innen recht		Bracket r.h.	Support droit
4	9032.17.01	1	Striegelschiene, links	3,0m	Harrow rail l.h.	Plaque de herse gauche
5	9032.17.02	1	Striegelschiene, rechts	3,0m	Harrow rail r.h.	Plaque de herse droit
6	9008.51.10	2	Verbindungsflasche		Latch	Plat
7	1441D26	4	Scheibe	26 DIN1441	Washer	Rondelle
8	1481D845A	4	Spannstift	8x45 DIN1481 vz.	Dowel pin	Goupille serrage
9	7001.05.00	4	Spannstift	21x28	Dowel pin	Goupille serrage
10	931D1690PA	2	Sechskantschraube	M16x90 DIN931-8.8 vz.	Hex. bolt	Vis 6 pans
11	931D1680P	2	Sechskantschraube	M16x80 DIN931- 8.8	Hex. bolt	Vis 6 pans
12	125DA17A	2	Scheibe	A17 DIN125 vz.	Washer	Rondelle
13	126D22A	4	Scheibe	22 DIN126 vz.	Washer	Rondelle
14	980DV16PA	2	Sicherungsmutter	VM16 DIN980-8 vz.	Lock nut	Ecrou frein
15	985D16PA	2	Sechskantmutter	M16 DIN985-8 vz.	Hex. nut	Ecrou 6 pans
16	6248.14.00	2	Steckbolzen	Ø16 mm	Pin	Axe
17	1481D645A	2	Spannstift	6x45 DIN1481 vz.	Dowel pin	Goupille serrage
18	4716.35.00	2	Federsteckstock	BTB-4	R-clip	Goupille beta
19	9032.19.10	2	Federlasche		Latch	Plat
20	9032.19.11	2	Parabel-Feder	30x36	Spring	Ressort
21	985D12PA	2	Sechskantmutter	M12 DIN985-8 vz.	Hex. nut	Ecrou 6 pans
23	6251.44.08	18	Klammer		Clasp	Crampon
24	6337.49.02	18	Striegelzinken	P 84	Harrow tine	Dent de herse
25	931D865PA	36	Sechskantschraube	M8x65 DIN931-8.8 vz.	Hex.bolt	Vis 6 pans
26	985D8PA	36	Sechskantmutter	M8 DIN985-8 vz.	Hex.nut	Ecrou 6 pans
	.					
	.					
	.					
	.					
	.					
	.					
	.					
	.					
	.					
	.					
	.					

P1

Striegelschiene 4,0+4,5m  
 Harrow rail 4,0+4,5m  
 plaque de herse 4,0+4,5m

MegaSeed 4000 K2, 4500 K2

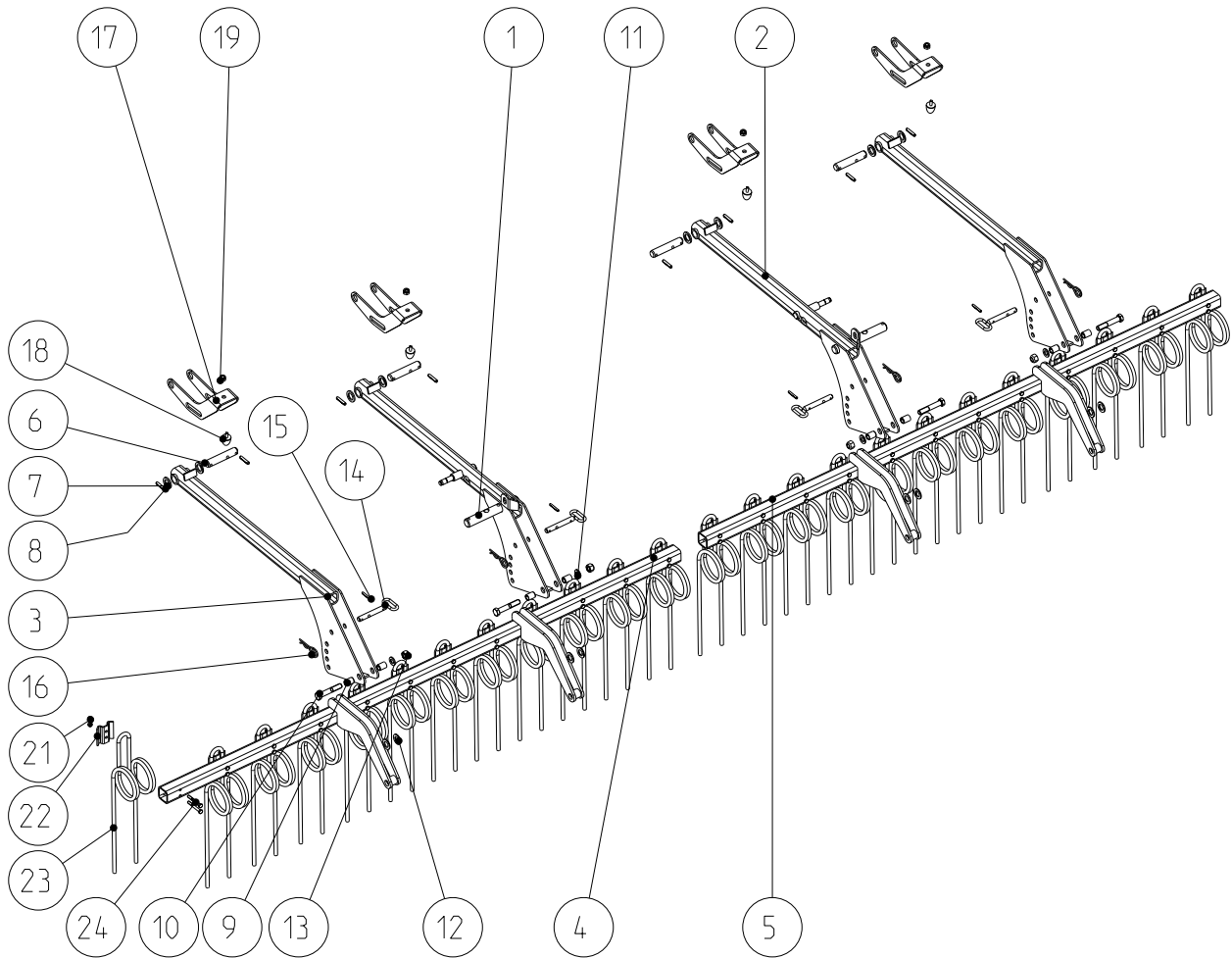



**P1**

Striegelschiene  
Harrow rail  
Plaque de herse

**MegaSeed 4001 K2, 4501 K2 Br.3/Serie 3**

Bild Ref. Fig.	Bestellnr. Part.-No. Référence	Stck Qty. Qte.	Bezeichnung	Technische Angaben Technical data Données techniques	Description	Désignation
1-24	9032.19.06	1	STRIEGELSCHIENE KPL.	4,0m	HARROW RAIL CPL.	PLAQUE DE HERSE CPL.
1-24	9032.19.05	1	STRIEGELSCHIENE KPL.	4,5m	HARROW RAIL CPL.	PLAQUE DE HERSE CPL.
.	.	.	.	.	.	.
1	9032.16.04	4	Striegelhalter		Bracket	Support
2	9032.74.04	4	Verstellhebel, links		Adjusting arm l.h.	Levier gauche
3	9032.68.02	4	Striegellenker		Link	Guide
4	VK50504X1950	1	Vierkantrrohr	L=1950 mm	Square pipe	Tube carré
4	VK50504X2200	1	Vierkantrrohr	L=2200 mm	Square pipe	Tube carré
5	6464.05.10	37,41	Bügelschraube		Bolt	Vis
6	9032.19.15	33,37	Halteplatte		Plate	Plaquette
7	6464.05.11	33,37	Striegelzinken		Harrow tine	Dent de herse
8	985D12PA	74,82	Sechskantmutter	M12 DIN985-8 vz.	Hex.nut	Ecrou 6 pans
9	7518.06.00	4	Tiefenstellspindel		Adjusting crank	Vis de réglage
10	6916D25	8	Scheibe	25 DIN6916	Washer	Rondelle
11	8415.00.34	4	Druckfeder	DF-215	Compression spring	Ressort
12	9032.19.19	8	Sechskantmutter verz.	Tr22x5	Hex.nut	Ecrou 6 pans
13	1441D17A	8	Scheibe	17 DIN1441 vz.	Washer	Rondelle
14	1481D630A	4	Spannstift	6x30 DIN1481 vz.	Dowel pin	Goupille serrage
15	931D2090PA	4	Sechskantschraube	M20x90 DIN931-8.8 vz.	Hex.bolt	Vis 6 pans
16	985D20PA	4	Sechskantmutter	M20 DIN985-8 vz.	Hex.nut	Ecrou 6 pans
17	6248.14.00	4	Steckbolzen	Ø16 mm	Pin	Axe
18	7515.00.02	4	Spindelmutter	MF-53	Spindleguide	Ecrou de manivelle
19	1000.05.05	4	Bolzen	Ø25mm	Pin	Axe
20	1441D26	8	Scheibe	26 DIN1441	Washer	Rondelle
21	1481D845A	8	Spannstift	8x45 DIN1481 vz.	Dowel pin	Goupille serrage
22	1481D645A	4	Spannstift	6x45 DIN1481 vz.	Dowel pin	Goupille serrage
23	4716.35.00	4	Federsteckstock	BTB-4	R-clip	Goupille beta
24	VK50504X2075	1	Vierkantrrohr	L=2075 mm	Square pipe	Tube carré
24	VK50504X2325	1	Vierkantrrohr	L=2325 mm	Square pipe	Tube carré
.	.	.	.	.	.	.
.	.	.	.	.	.	.
.	.	.	.	.	.	.
.	.	.	.	.	.	.
.	.	.	.	.	.	.
.	.	.	.	.	.	.
.	.	.	.	.	.	.
.	.	.	.	.	.	.
.	.	.	.	.	.	.
.	.	.	.	.	.	.

P2

Striegelschiene 6m  
Harrow rail 6m  
Plaque de herse 6m

MegaSeed 6002 K2

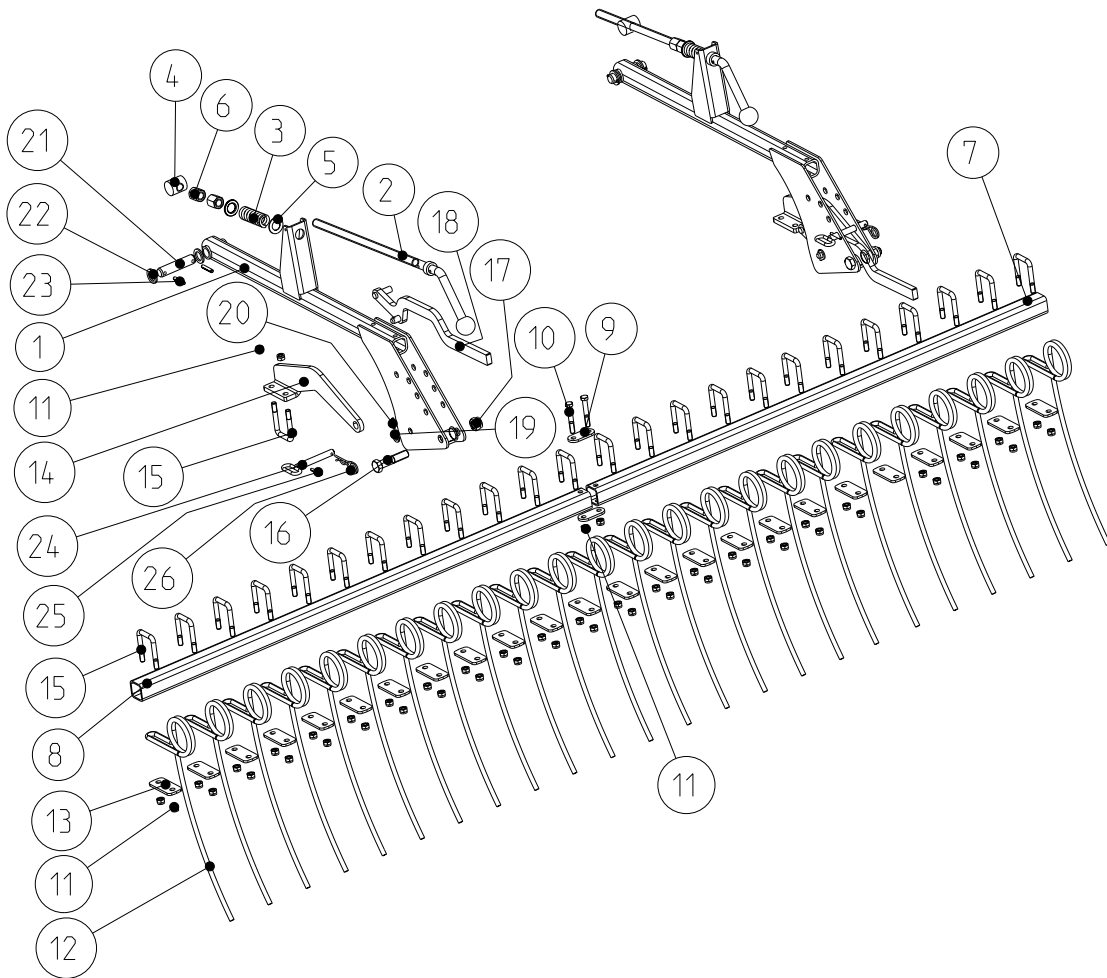



**P2**

Striegelschiene  
Harrow rail  
Plaque de herse

**MegaSeed 6002 K2**

Bild Ref. Fig.	Bestellnr. Part.-No. Référence	Stck Qty. Qte.	Bezeichnung	Technische Angaben Technical data Données techniques	Description	Désignation
1-26	9032.19.04	1	STRIEGELSCHIENE KPL.	6,0m	HARROW RAIL CPL.	PLAQUE DE HERSE CPL.
.	.	.	.	.	.	.
1	9032.16.04	4	Striegelschiene	6m	Harrow rail	Plaque de herse
2	7518.06.00	4	Tiefenstellspindel		Adjusting crank	Vis de réglage
3	8415.00.34	4	Druckfeder	DF-215	Compression spring	Ressort
4	7515.00.02	4	Spindelmutter MF-53	Spindelmutter MF-53	Spindleguide	Ecrou de manivelle
5	6916D25	8	Scheibe	25 DIN6916	Washer	Rondelle
6	9032.19.19	8	Sechskantmutter verz.	Tr22x5	Hex.nut	Ecrou 6 pans
7	9032.19.16	1	Striegelschiene, lang		Harrow rail long	Plaque de herse long
8	9032.19.17	3	Striegelschiene, kurz		Harrow rail short	Plaque de herse court
9	9032.19.18	4	Verbindungsflasche		Latch	Plat
10	931D1280PA	4	Sechskantschraube	M12x80 DIN931-8.8 vz.	Hex.bolt	Vis 6 pans
11	985D12PA	110	Sechskantmutter	M12 DIN985-8 vz.	Hex.nut	Ecrou 6 pans
12	6464.05.11	49	Striegelzinken		Harrow tine	Dent de herse
13	9032.19.15	49	Halteplatte		Plate	Plaquette
14	9032.68.02	4	Striegellenker		Link	Guide
15	6464.05.10	53	Bügelsschraube		Bolt	Vis
16	931D2090P	4	Sechskantschraube	M20x90 DIN931-8.8	Hex. bolt	Vis 6 pans
17	985D20PA	4	Sechskantmutter	M20 DIN985-8 vz.	Hex.nut	Ecrou 6 pans
18	9032.74.02	4	Verstellhebel		Adjusting arm	Levier
19	1441D17A	8	Scheibe	17 DIN1441 vz.	Washer	Rondelle
20	1481D630A	4	Spannstift	6x30 DIN1481 vz.	Dowel pin	Goupille serrage
21	1000.05.05	4	Bolzen	Ø25mm	Pin	Axe
22	1441D26A	8	Scheibe	26 DIN1441 verz.	Washer	Rondelle
23	1481D845A	8	Spannstift	8x45 DIN1481 vz.	Dowel pin	Goupille serrage
24	6248.14.00	4	Steckbolzen	Ø16 mm	Pin	Axe
25	1481D645A	4	Spannstift	6x45 DIN1481 vz.	Dowel pin	Goupille serrage
26	4716.35.00	4	Federsteckstock	BTB-4	R-clip	Goupille beta
.	.	.	.	.	.	.
.	.	.	.	.	.	.
.	.	.	.	.	.	.
.	.	.	.	.	.	.
.	.	.	.	.	.	.
.	.	.	.	.	.	.
.	.	.	.	.	.	.
.	.	.	.	.	.	.
.	.	.	.	.	.	.
.	.	.	.	.	.	.
.	.	.	.	.	.	.
.	.	.	.	.	.	.

R

Spuranreißer  
Track marker  
Traceurs

MegaSeed 3001

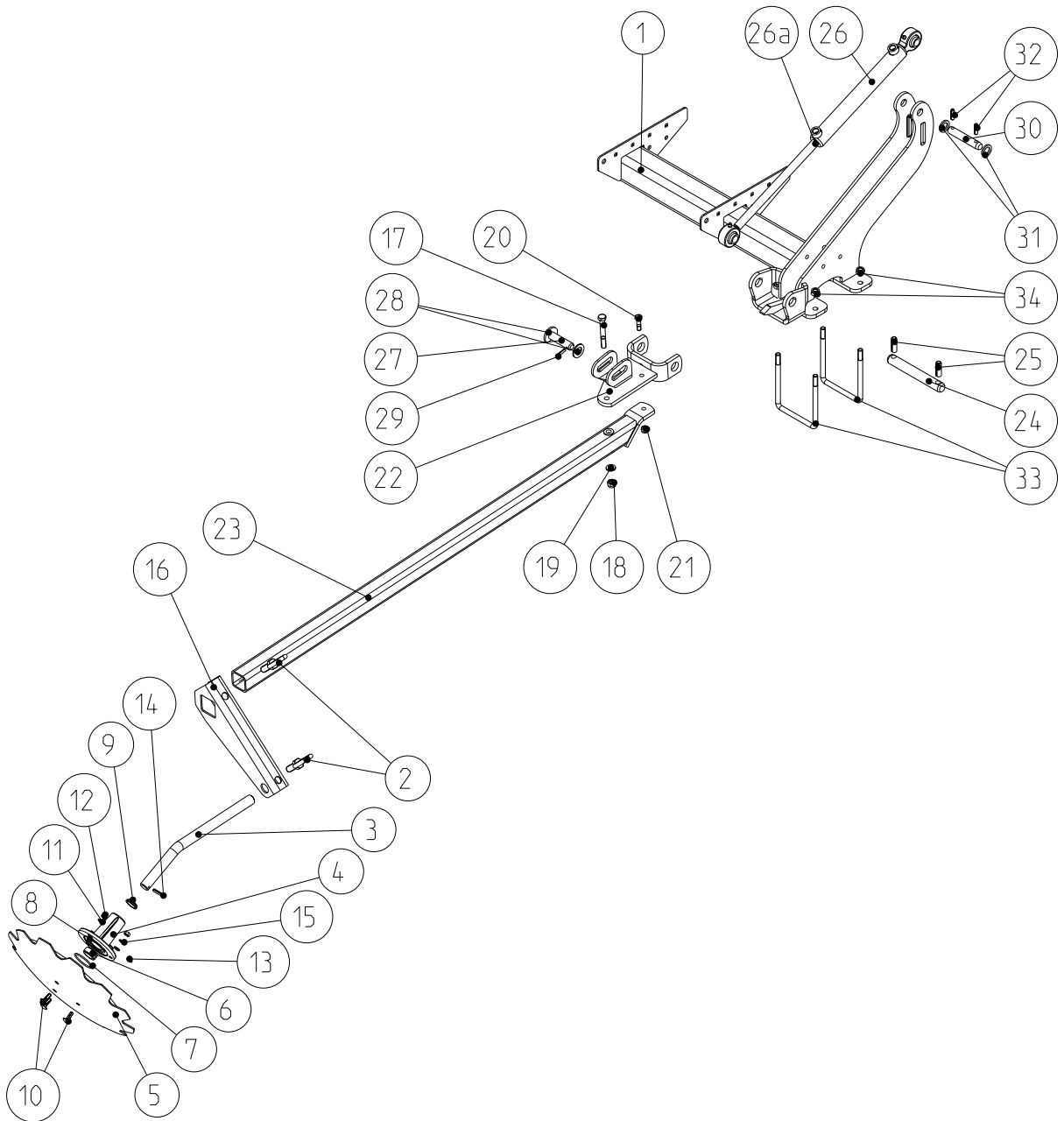



**R**

Spuranreißer  
Track marker  
Traceurs

**MegaSeed 3001 S**

Bild Ref. Fig.	Bestellnr. Part.-No. Référence	Stck Qty. Qte.	Bezeichnung	Technische Angaben Technical data Données techniques	Description	Désignation
1-34	9031.06.34	1	SPURANREISSER, LI.	3,0 m	TRACK MARKER L.H.	TRACEURS GAUCHE
1-34	9031.06.35	1	SPURANREISSER, RE.	3,0 m	TRACK MARKER R.H.	TRACEURS DROIT
1	9032.14.06	1	Anlenkung, außen links		Link arm l.h.	Bras réglable gauche
1	9031.06.30	1	Anlenkung, außen		Link arm	Bras réglable
2-23	9008.07.02	1	SPURREISSER LINKS	3,0 m	DISC MARKER L.H.	TRACEUR GAUCHE
2-23	9008.07.01	1	SPURREISSER RECHTS	3,0 m	DISC MARKER R.H.	TRACEUR DROIT
2	9001.39.01	2	Ösenschraube		Eye bolt	Piton
3-15	9111.78.01	1	MARKIERER GEZACKT		MARKER CPL.	DISQUE CPL.
3	9001.38.03	1	Spuranreißerwelle		Cranked shaft	Arbre d'effaceur
4	9001.38.05	1	Spuranreißernabe		Hub	Moyeu
5	9111.78.21	1	Markierscheibe gezackt	Ø400 mm	Disc	Disque traceur
6	9001.38.04	1	Lagerring		Bush	Baque
7	9001.38.06	1	O-Ring	49x3	O-seal	Joint torique
8	988D25352	1	Paßscheibe	25x35x2 DIN988	Gauge washer	Cale d'ajustage
9	8163.00.10	1	Abstreifer	25x33x7	Scraper	Décrottoir
10	603D825PA	3	Flachrundschrabe	M8x25 DIN603-8.8 vz.	Bolt	Vis
11	127DA8A	3	Federring	A8 DIN127 vz.	Springwasher	Rondelle grower
12	934D8PA	3	Sechskantmutter	M8 DIN934-8 vz.	Hex. nut	Ecrou 6 pans
13	71412DA81	1	Schmiernippel	AM8x1 DIN71412	Grease nipple	Graisneur
14	1481D632	1	Spannstift	6x32 DIN1481	Dowel pin	Goupille serrage
15	125DA8.4A	3	Scheibe	A8,4 DIN125 vz.	Washer	Rondelle
16	9001.41.01	1	Spuranreißerhalter		Bracket	Support
17	931D1290PA	1	Sechskantschraube	M12x90 DIN931-8.8 vz.	Hex. bolt	Vis 6 pans
18	980DV12PA	1	Sicherungsmutter	VM12 DIN980-8 vz.	Lock nut	Ecrou frein
19	125DA13A	2	Scheibe	A13 DIN125 vz.	Washer	Rondelle
20	601D1035A	1	Sechskantschraube	M10x35 DIN601 vz.	Hex. bolt	Vis 6 pans
21	985D10PA	1	Sechskantmutter	M10 DIN985-8 vz.	Hex.nut	Ecrou 6 pans
22	9008.45.02	1	Armelenk, links		Joint	Articulation
22	9008.45.01	1	Armelenk, rechts		Joint	Articulation
23	9008.38.01	1	Spurreißerarm	3,0 m	Boom	Bras
24	9001.00.28	1	Gelenkbolzen		Pin	Broche
25	1481D1340A	2	Spannstift	13x40 DIN1481 vz.	Dowel pin	Goupille serrage
26	8163.06.01	1	ZYLINDER	SM4910/40X281X450	CYLINDER CPL.	VERIN CPL.



**R1**

Spuranreißer  
Track marker  
Traceurs

**MegaSeed 4000 K2, 4500 K2**

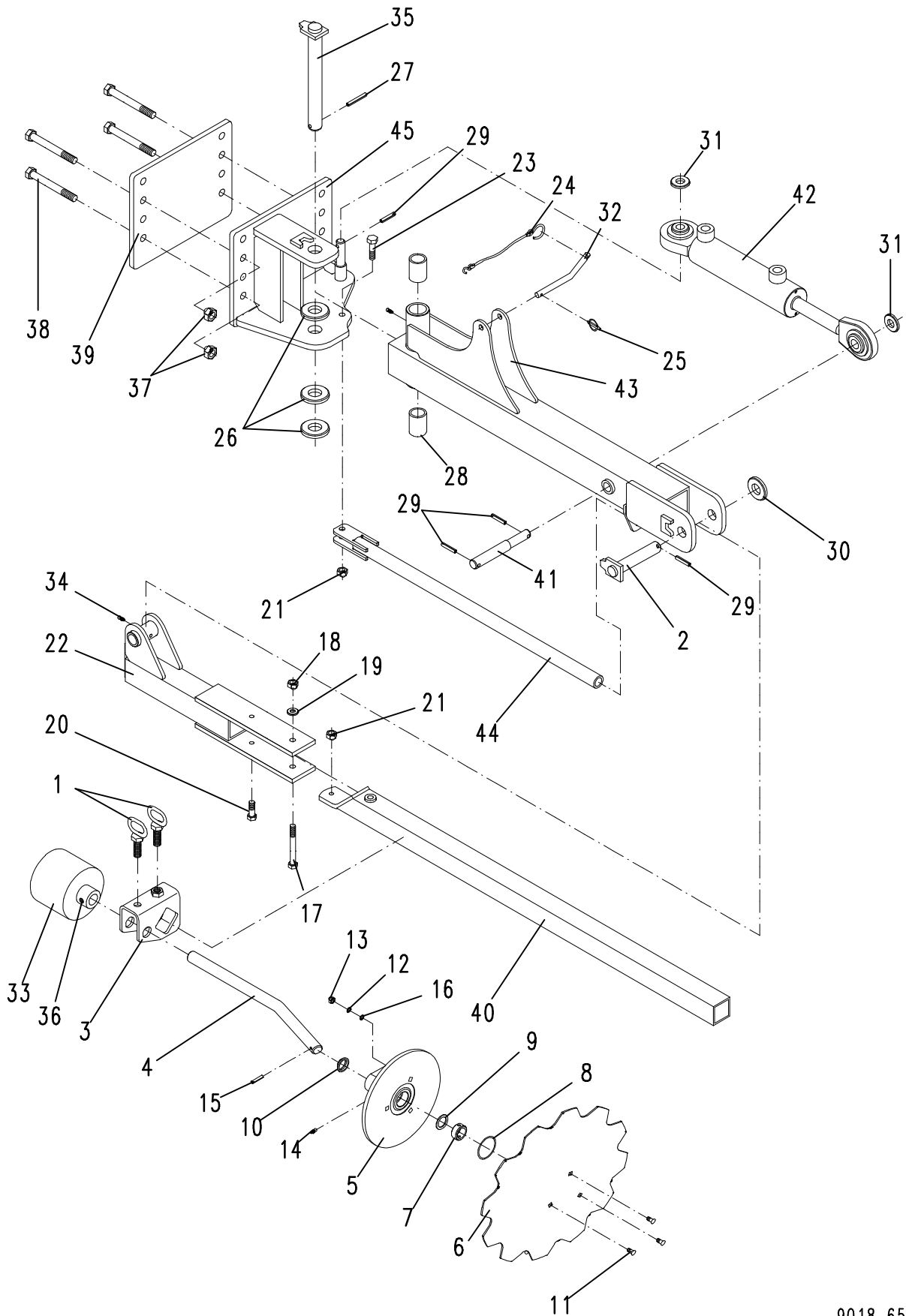



**R1**

Spuranreißer  
Track marker  
Traceurs

**MegaSeed 4000 K2, 4500 K2**

Bild Ref. Fig.	Bestellnr. Part.-No. Référence	Stck Qty. Qte.	Bezeichnung	Technische Angaben Technical data Données techniques	Description	Désignation
	9018.65.01	1	SPURANREISSER LINKS	4,0 m	TRACK MARKER L.H.	TRACEURS GAUCHE
	9018.65.02	1	SPURANREISSER RECHTS	4,0 m	TRACK MARKER R.H.	TRACEURS DROIT
	9018.65.07	1	SPURANREISSER LINKS	4,5 m	TRACK MARKER L.H.	TRACEURS GAUCHE
	9018.65.08	1	SPURANREISSER RECHTS	4,5 m	TRACK MARKER R.H.	TRACEURS DROIT
1	9001.39.01	2	Ösenschraube		Eye bolt	Piton
2	4745.18.00	2	Spannschloßbolzen	ZB-25X137	Turnbuckle pin	Axe
3	9018.66.01	1	Spuranreißerhalter		Bracket	Support
4-16	9111.78.01	1	MARKIERER GEZACKT		MARKER CPL.	DISQUE CPL.
4	9001.38.03	1	Spuranreißerwelle		Cranked shaft	Arbre d'effaceur
5	9001.38.05	1	Spuranreißernabe		Hub	Moyeu
6	9111.78.21	1	Markierscheibe gezackt	Ø400 mm	Disc	Disque traceur
7	9001.38.04	1	Lagerring		Bush	Baque
8	9001.38.06	1	O-Ring	49x3	O-seal	Joint torique
9	988D25352	1	Paßscheibe	25x35x2 DIN988	Gauge washer	Cale d'ajustage
10	8163.00.10	1	Abstreifer	25x33x7	Scraper	Décrottoir
11	603D825PA	3	Flachrundschrabe	M8x25 DIN603-8.8 vz.	Bolt	Vis
12	127DA8A	3	Federring	A8 DIN127 vz.	Springwasher	Rondelle grower
13	934D8PA	3	Sechskantmutter	M8 DIN934-8 vz.	Hex. nut	Ecrou 6 pans
14	71412DA81	1	Schmiernippel	AM8x1 DIN71412	Grease nippel	Graisser
15	1481D632	1	Spannstift	6x32 DIN1481	Dowel pin	Goupille serrage
16	125DA8.4A	3	Scheibe	A8,4 DIN125 vz.	Washer	Rondelle
17	931D12100PA	1	Sechskantschraube	M12x100 DIN931-8.8 vz.	Hex. bolt	Vis 6 pans
18	980DV12PA	1	Sicherungsmutter	VM12 DIN980-8 vz.	Lock nut	Ecrou frein
19	126D14A	1	Scheibe	14 DIN126 vz.	Washer	Rondelle
20	933D1035PA	1	Sechskantschraube	M10x35 DIN933-8.8 vz.	Hex. bolt	Vis 6 pans
21	985D12PA	2	Sechskantmutter	M12 DIN985-8 vz.	Hex. nut	Ecrou 6 pans
22	9019.04.01	1	Scherarm		Arm	Bras
23	933D1245PA	1	Sechskantschraube	M12x45 DIN933-8.8 vz.	Hex. bolt	Vis 6 pans
24	8163.07.01	1	Sicherungsband		Safety strap	Caotchouc
25	8405.12.09	1	Klappstecker	STB-4,5x340	Linch-pin	Goupille auto.
26	126D30A	3	Scheibe	30 DIN126 vz.	Washer	Rondelle
27	1481D855A	1	Spannstift	8x55 DIN1481 vz.	Dowel pin	Goupille serrage
28	1498D303850	2	Buchse	EG 30x38x50 DIN1498	Bush	Douille
29	1481D840A	4	Spannstift	8x40 DIN1481 vz.	Dowel pin	Goupille serrage
30	126D26A	1	Scheibe	26 DIN126 vz.	Washer	Rondelle



**R2**

Hydraulik für Spuranreißer

Hydr. pipe track marker

**MegaSeed 3001 S**

Hydraulique de traceurs

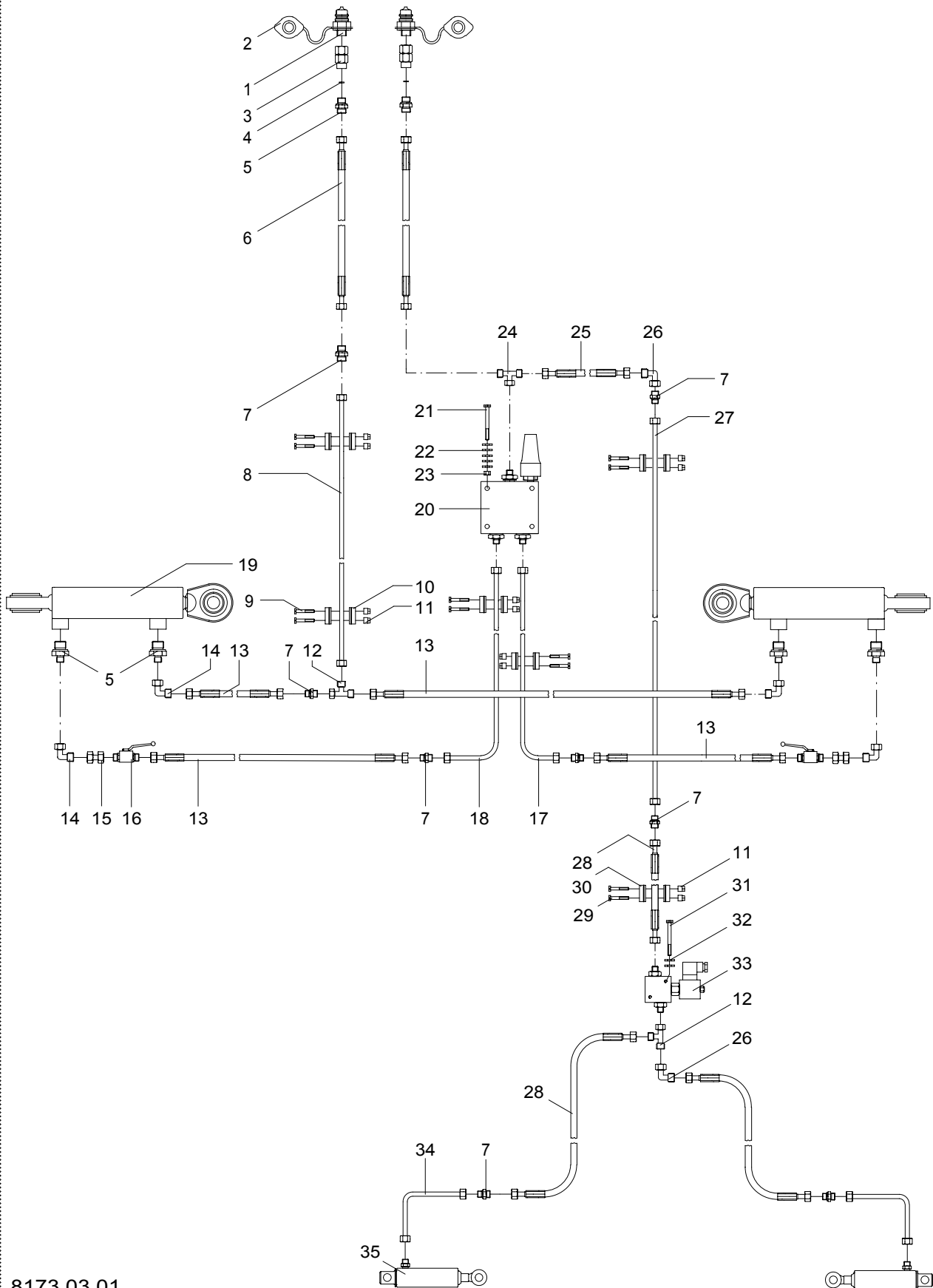

8173.03.01

8173.03.02



**R2**

Hydraulik für Spuranreißer  
Hydr.pipe track marker  
Hydraulique de traceurs

**MegaSeed 3001 S**

Bild Ref. Fig.	Bestellnr. Part.-No. Référence	Stck Qty. Qte.	Bezeichnung	Technische Angaben Technical data Données techniques	Description	Désignation
	8173.03.01	1	HYDRAULIK F.SPURANREISS.	3,0m	HYDR.PIPE CPL.	HYDRAULIQUE CPL.
	8173.03.02	1	HYDRAUL. F FAHRGASSENMARK.	3,0m	HYDR.PIPE CPL.	HYDRAULIQUE CPL.
1	8132.01.00	2	Kupplungsstecker	ISO 5675	Coupling	Raccord
2	8132.05.05	2	Staubkappe, gelb		Dust cap yellow	Cache jaune
3	8165.21.04	2	Verbindung	DKOL 12/IG	Connecter	Assemblage
4	8165.21.09	2	Drosselscheibe	DRS 14.2/1,0	Restrictive washer	Etranglement
5	8163.06.20	6	Gerade Einschraubverschraub.	X VN NW06 HL 16 ED	Male stud coupling	Raccord
6	9001.60.46	2	Hydraulikschlauch	DN6 L=3500 A0/A0	Hydr. hose	Conduite flexible
7	9001.60.24	4,8	Gerade Verschraubung	G 8-L	Male stud coupling	Raccord
8	8172.11.02	1	Hydraulikrohr kpl.	L=1200 mm	Hydr.pipe cpl.	Tube cpl.
9	84D620W	8,12	Zylinderschraube	M6x20 DIN84-4.8	Spline screw	Vis cylindrique
10	4753.56.15	8,10	Schelle kpl.		Clip cpl.	Collier cpl.
11	4753.56.05	8,12	Schienenmutter		Nut	Ecrou
12	9004.19.10	1,2	Einstell. Anschlußstutz.	EVL8-PL	Coupling	Raccord
13	9001.60.22	4	Hydraulikschlauch	DN6, L=1600mm, A0/A0	Hydr. hose	Conduite flexible
14	4716.52.11	6	Einstellb. Winkelverschraub.	EVW-12 L	Elbow coupling	Raccord
15	9004.60.03	2	Doppelverbinder	GVO 8-L	Coupling	Tuyau rigide
16	8151.15.06	2	Kugelhahn	K-KHV 8L/NW 6	Ball valve	
17	8172.10.01	1	Hydraulikrohr kpl.	L=1391 mm	Hydr.pipe cpl.	Tube cpl.
18	8172.10.02	1	Hydraulikrohr kpl.	L=1461 mm	Hydr.pipe cpl.	Tube cpl.
19	8163.06.01	2	ZYLINDER	SM4910/40X281X450	CYLINDER CPL.	VERIN CPL.
20	9001.60.80	1	Wechselventil	EAK 701	Cartridge valve	Soupape consomm.
21	931D860PA	4	Sechskantschraube	M8X60 DIN931-8.8 vz.	Hex. bolt	Vis 6 pans
22	126D9A	20	Scheibe	9 DIN126 verz.	Washer	Rondelle
23	980DV8PA	4	Sicherungsmutter	VM8 DIN980-8 vz.	Lock nut	Ecrou frein
24	9109.51.01	1	T-Verschraubung		T-coupling	Raccord
25	8172.13.01	1	Hydraulikschlauch	DN6, L=400mm A0L/A0L	Hydr. hose	Conduite flexible
26	9004.17.08	2	Winkelanschlußstutzen		Elbow coupling	Raccord coude
27	8172.11.01	1	Hydraulikrohr kpl.	L=1950 mm	Hydr.pipe cpl.	Tube cpl.
28	8172.13.03	1	Hydraulikschlauch	DN6, L=2000 A0L/A0L	Hydr. hose	Conduite flexible
29	84D650W	2	Zylinderschraube	M6x50 DIN84-4.8	Spline screw	Vis cylindrique
30	4753.56.02	1	Schelle kpl.		Clip cpl.	Collier cpl.
31	84D635W	2	Zylinderschraube	M6x35 DIN84-4.8	Spline screw	Vis cylindrique
32	9021DA6.4A	6	Scheibe	A 6.4 DIN9021 vz.	Washer	Rondelle
33	9004.19.07	1	Elektr. Sitzventil	12 Volt	Electr. valve 12 V	Clapet
34	9006.77.01	2	Hydraulikrohr mont.	L=208 mm	Hydr. pipe	Tube
35	8163.00.21	2	ZYLINDER MONT.		CYLINDER CPL.	VERIN CPL.

**R3**

Hydraul. f. Spuranreißer, Fahrgassenmark.

Hydr.pipe track marker

**Hydr. Spuranr. / Fahrgassenmark. MegaSeed 4-4,5m**

Hydraul. pour traceurs, jalonnement

8173.06.02

8173.06.03

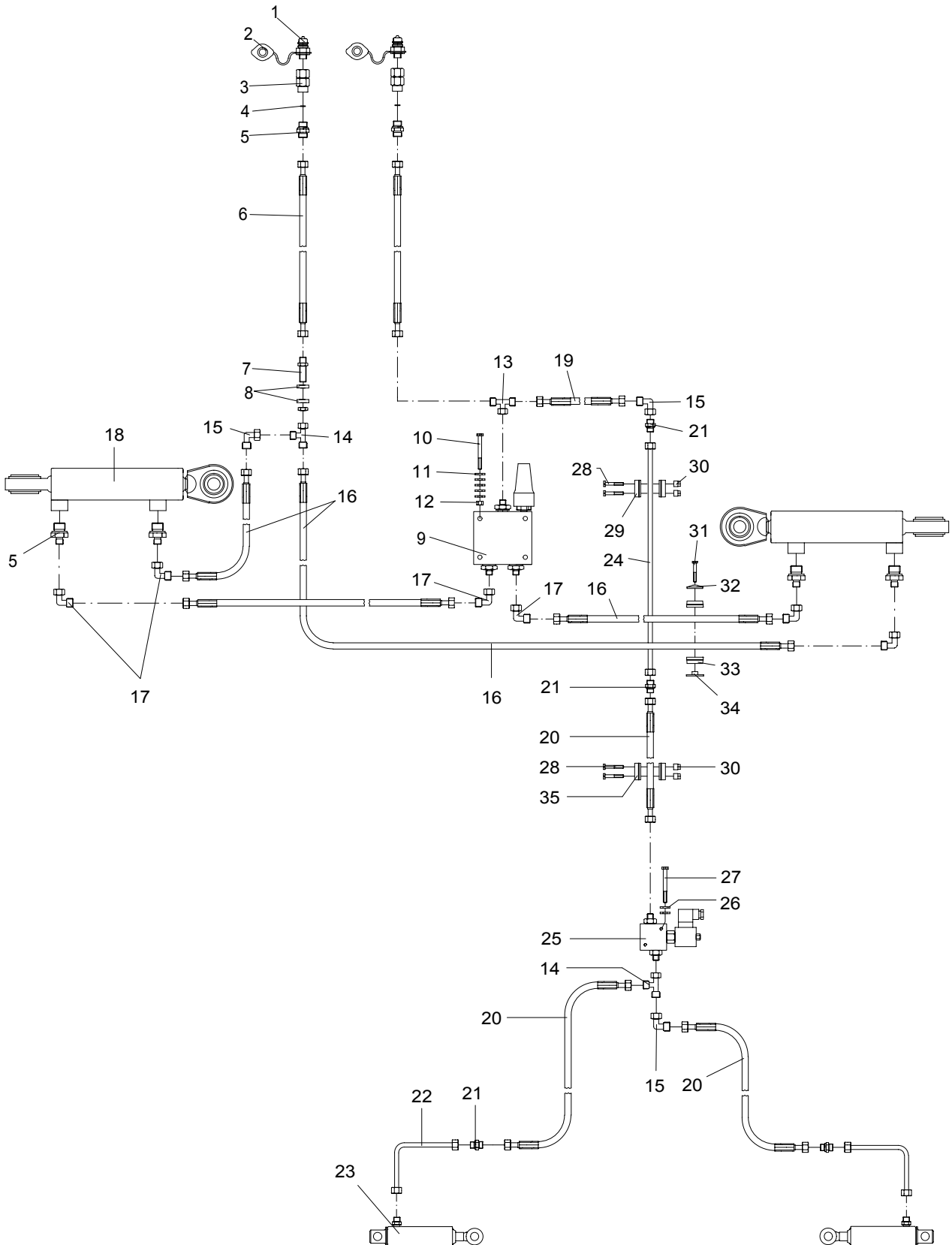



**R3**

Hydraul. f. Spuranreißer, Fahrgassenmark.  
Hydr. pipe track marker, pre-emerg. marker  
Hydraul. pour traceurs, jalonnement

**MegaSeed 4001 K2, 4501 K2 Br./Serie 0-2**

Bild Ref. Fig.	Bestellnr. Part.-No. Référence	Stck Qty. Qte.	Bezeichnung	Technische Angaben Technical data Données techniques	Description	Désignation
	8173.06.02	1	HYDRAULIK F. SPURANREISSER	4,0-4,5m	TRACK MARKER HYDR.	HYDR. POUR TRACEURS
	8173.06.03	1	HYDRAULIK F. FAHRGASSENMARK.	4,0-4,5m	PRE-EMERG.MARK. HYD	HYDR. POUR JALONNEM.
1	8132.01.00	2	Kupplungsstecker	ISO 5675	Coupling	Raccord
2	8132.05.05	2	Staubkappe, gelb		Dust cap yellow	Cache jaune
3	8165.21.04	2	Verbindung	DKOL 12/IG	Connecter	Assemblage
4	8165.21.09	2	Drosselscheibe	DRS 14.2/1,0	Restrictive washer	Etranglement
5	8163.06.20	2	Gerade Einschraubverschraub.	X VN NW06 HL 16 ED	Male stud coupling	Raccord
6	9001.60.46	2	Hydraulikschlauch	DN6 L=3500 A0/A0	Hydr. hose	Conduite flexible
7	9001.60.21	1	Gerade Schottversch.		Nut coupling	Raccord
8	125DA15A	2	Scheibe	A15 DIN125 vz.	Washer	Rondelle
9	9001.60.80	1	Wechselventil	EAK 701	Cartridge valve	Soupape consomm.
10	931D860PA	4	Sechskantschraube	M8X60 DIN931-8.8 vz.	Hex. bolt	Vis 6 pans
11	126D9A	20	Scheibe	9 DIN126 verz.	Washer	Rondelle
12	980DV8PA	4	Sicherungsmutter	VM8 DIN980-8 vz.	Lock nut	Ecrou frein
13	9109.51.01	1	T-Verschraubung		T-coupling	Raccord
14	9004.19.10	1,2	Einstell. Anschlußstutz.	EVL8-PL	Coupling	Raccord
15	9004.17.08	1,3	Winkelanschlußstutzen		Elbow coupling	Raccord coude
16	8172.13.02	4	Hydraulikschlauch	DN6, L=4000mm, A0L/A0L	Hydr. hose	Conduite flexible
17	4716.52.11	6	Einstellb. Winkelverschraub.	EVW-12 L	Elbow coupling	Raccord
18	8163.06.01	2	ZYLINDER	SM4910/40X281X450	CYLINDER CPL.	VERIN CPL.
19	8172.13.01	1	Hydraulikschlauch	DN6, L=400mm A0L/A0L	Hydr. hose	Conduite flexible
20	8172.13.03	3	Hydraulikschlauch	DN6, L=2000 A0L/A0L	Hydr. hose	Conduite flexible
21	9001.60.24	4	Gerade Verschraubung	G 8-L	Male stud coupling	Raccord
22	9006.77.01	2	Hydraulikrohr mont.	L=208 mm	Hydr. pipe	Tube
23	8163.00.21	2	ZYLINDER MONT.		CYLINDER CPL.	VERIN CPL.
24	8172.11.01	1	Hydraulikrohr kpl.	L=1950 mm	Hydr. pipe cpl.	Tube cpl.
25	9004.19.07	1	Elektr. Sitzventil	12 Volt	Electr. valve 12 V	Clapet
26	9021DA6.4A	6	Scheibe	A 6.4 DIN9021 vz.	Washer	Rondelle
27	84D635W	2	Zylinderschraube	M6x35 DIN84-4.8	Spline screw	Vis cylindrique
28	84D650W	6	Zylinderschraube	M6x50 DIN84-4.8	Spline screw	Vis cylindrique
29	4753.56.15	3,6	Schelle kpl.		Clip cpl.	Collier cpl.
30	4753.56.05	6	Schienenmutter		Nut	Ecrou
31	931D635PA	6	Sechskantschraube	M6x35 DIN931-8.8 verz.	Hex.bolt	Vis 6 pans
32	4753.56.08	6	Deckplatte		Lid	Couvercle
33	4753.56.07	6,12	Doppelschelle		Double clip	Collier double
34	4753.56.06	6	Einzelanschweißplatte		Plate	Plaquette
35	4753.56.02	1,2	Schelle kpl.		Clip cpl.	Collier cpl.

**R4**

Zylinder f. Spuranreisser  
Track markers cylinder  
Verin de Traceurs

**Zylinder/Cylinder/Verin SM4910/40x281x450**

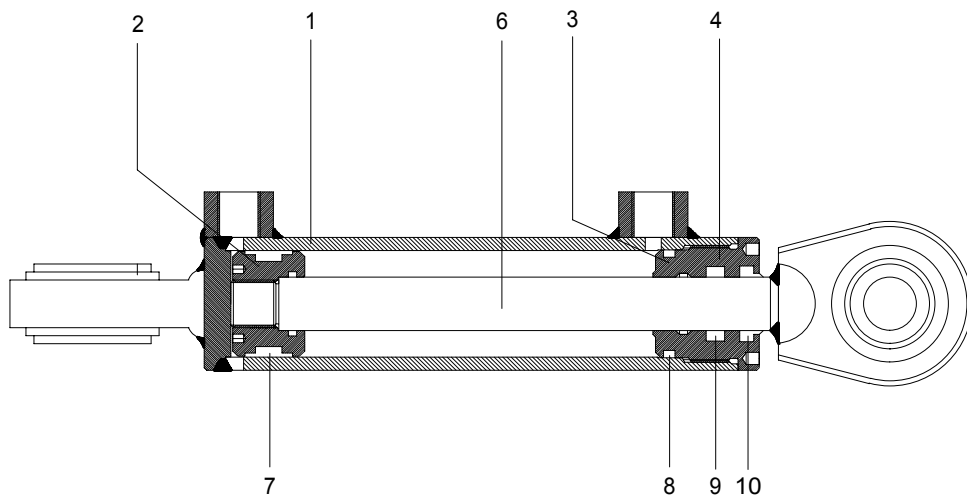

8163.06.01



**R5**

Zylinder f. Fahrgassenmarkier.

Pre-emergence markers cyl. **Zylinder / Cylinder / Verin (8163.00.21)**

Verin de jalonnement

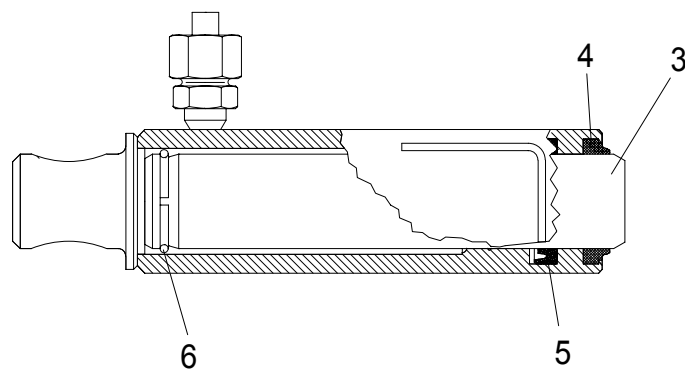



S

Fahrgassenmarkierung  
Pre-emergence markers  
Jalonnement

Combi-Speed XL, Turbodrill T, MegaSeed 3,0 - 4,5m

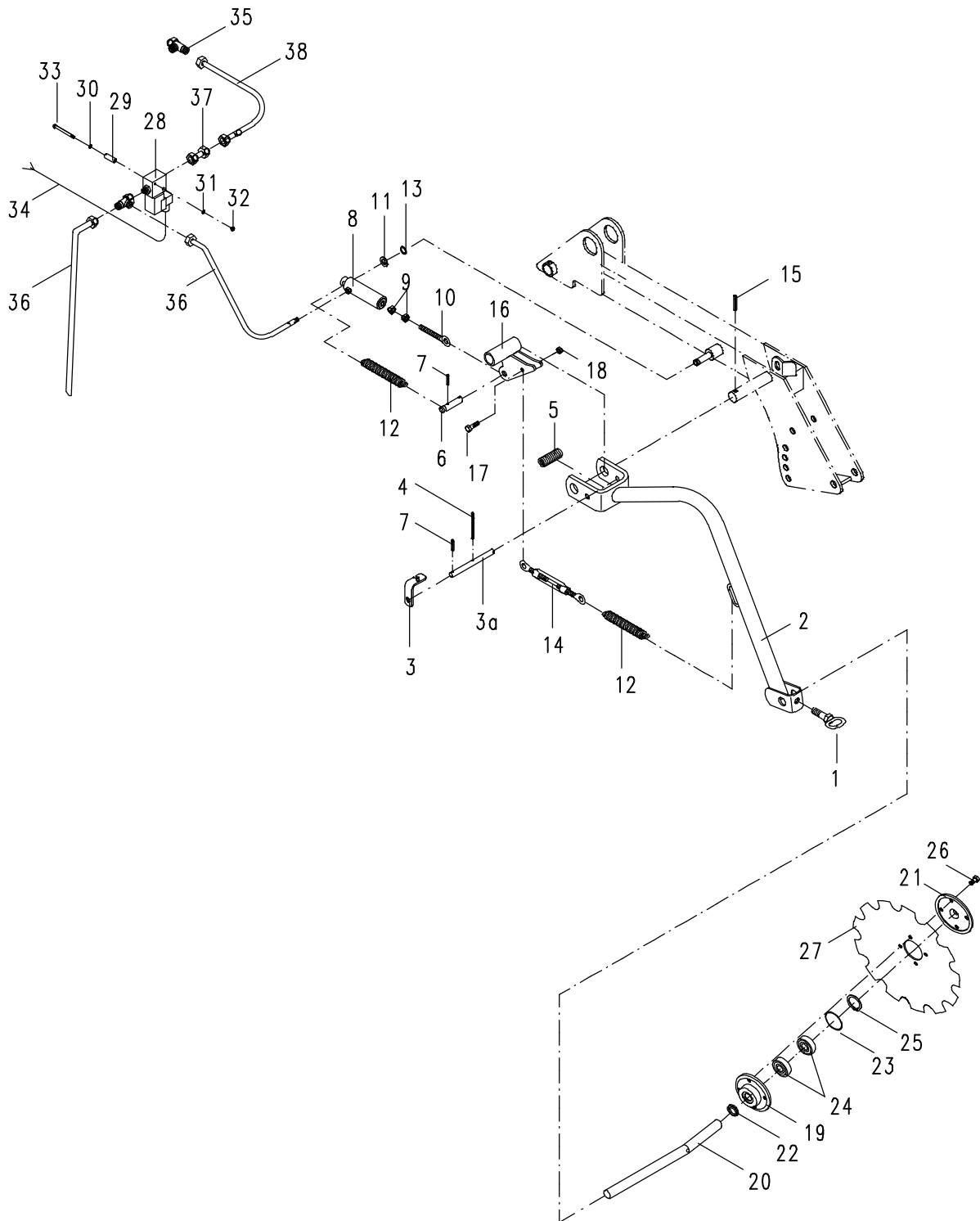



**S**

Fahrgassenmarkierung  
Pre-emergence markers  
Jalonnement

**Combi-Speed XL, Turbodrill T, MegaSeed 3,0m - 4,5m**

Bild Ref. Fig.	Bestellnr. Part.-No. Référence	Stck Qty. Qte.	Bezeichnung	Technische Angaben Technical data Données techniques	Description	Désignation
1-27	9018.34.01	1	FAHRGASSENMARK.		PRE-EMERG. MARK.	JALONNEMENT CPL.
1	9001.39.01	2	Ösenschraube		Eye bolt	Piton
2	9008.87.01	2	Scheibenträger		Disc arm	Support de disque
3	9018.34.10	2	Verriegelungslasche		Latch	Plat
3a	9004.19.03	2	Riegelbolzen verzinkt		Pin	Axe
4	1481D680A	2	Spannstift	6x80 DIN1481 verz.	Dowel pin	Goupille serrage
5	9001.36.02	2	Druckfeder	DF-211	Compression spring	Ressort
6	9004.19.02	2	Kolbenbolzen		Plunger pin	Axe
7	1481D630A	6	Spannstift	6x30 DIN1481 vz.	Dowel pin	Goupille serrage
8-10	8163.00.21	2	ZYLINDER MONT.		CYLINDER CPL.	VERIN CPL.
8	8163.00.01	2	ZYLINDER VERSTELLB.		CYLINDER	VERIN
9	936D16PA	4	Sechskantmutter	M16 DIN936-8 verz.	Hex. nut	Ecrou 6 pans
10	444DB1675PA	2	Augenschraube	BM16x75 DIN444-8.8 vz	Eye bolt	Vis à oeil
11	988D16221.5	2	Paßscheibe	16x22x1,5 DIN988	Gauge washer	Cale d'ajustage
12	4726.00.07	4	Zugfeder	CF-209	Tension spring	Ressort
13	471D161	2	Sicherungsring	16x1 DIN471	Circlip	Circlip
14	1480DSP12A	2	Spannschloß	SP12 DIN1480 verz.	Turnbuckle	Tirant
15	1481D845A	2	Spannstift	8x45 DIN1481 vz.	Dowel pin	Goupille serrage
16	9004.49.01	1	Hebel, links		Lever l.h.	Levier gauche
16	9004.49.02	1	Hebel, rechts		Lever r.h.	Levier droit
17	933D1030PA	2	Sechskantschraube	M10x30 DIN933-8.8 vz.	Hex. bolt	Vis 6 pans
18	985D10PA	2	Sechskantmutter	M10 DIN985-8 vz.	Hex. nut	Ecrou 6 pans
19-27	9018.37.01	2	MARKIERER MONT.		MARKER CPL.	DISQUE CPL.
19	9008.56.10	2	Lagergehäuse		Bearing housing	Braquette
20	9018.37.11	2	Spuranreißerwelle		Cranked shaft	Arbre d'effaceur
21	9008.56.12	2	Lagerdeckel		Lid	Couvercle
22	9008.03.13	2	Dichtring	V-Seal TWVA 00250	Seal ring	Joint
23	8404.26.25	2	O-Ring	55x2,5	O-seal	Joint torique
24	625D63042RS1	4	Rillenkugellager	6304 2RS1 DIN625	Ball bearing	Roulement à billes
25	471D201.2	2	Sicherungsring	20x1,2 DIN471	Circlip	Circlip
26	8426.13.09	8	Verbus-Ripp 6ktschr.	M10x20-100	Bolt	Vis
27	9008.55.10	2	Räumscheibe gezackt		Disc notched	Rondelle crênelé
28	9004.19.07	1	Elektr. Sitzventil	12 Volt	Electr. valve 12 V	Clapet
29	9004.19.14	2	Distanzhülse verzinkt		Spacer	Bague entretoise



T

Beleuchtungseinrichtung  
Light kit  
Kit d'éclairage

MegaSeed 3001 S

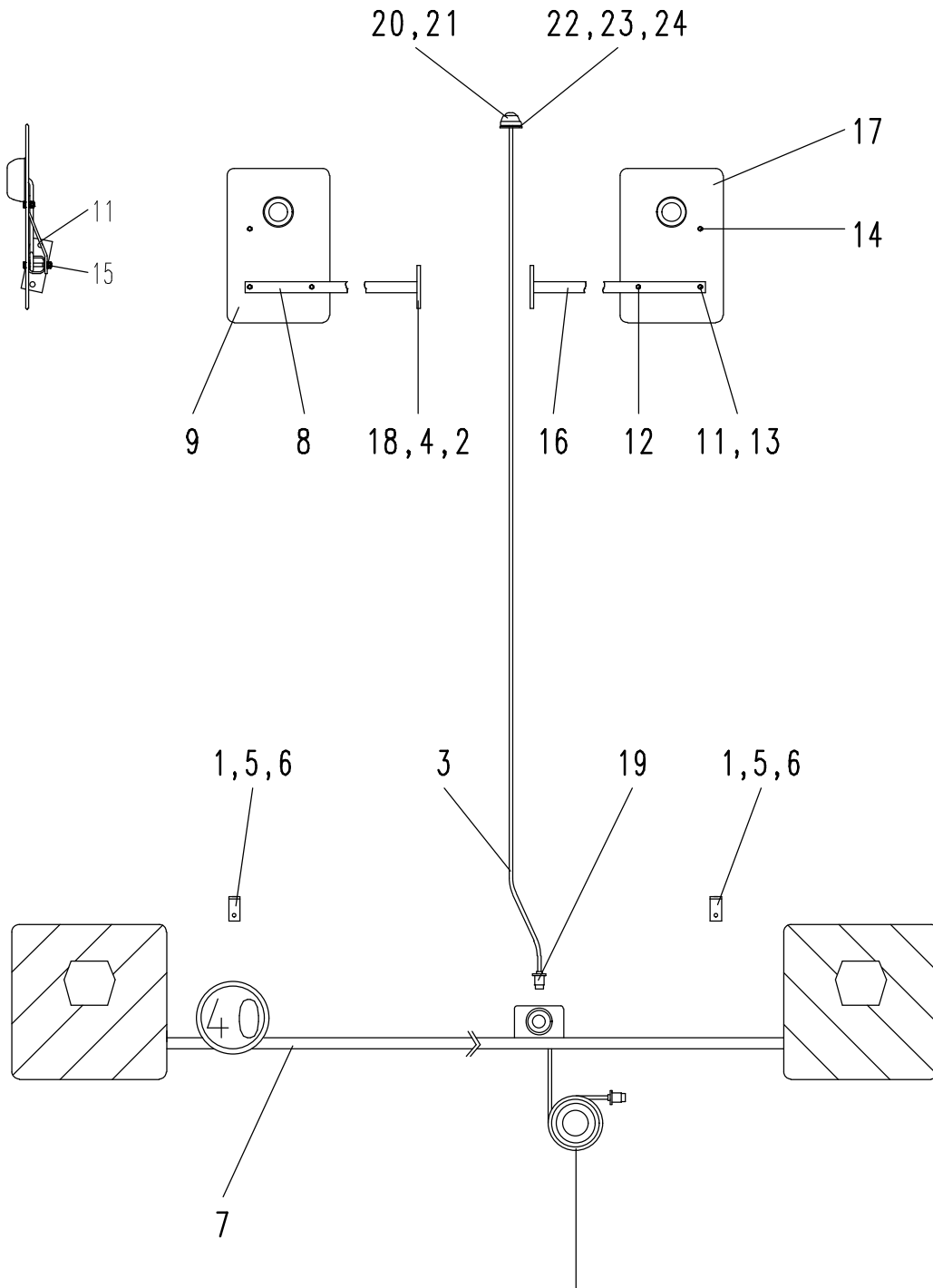

Kabel zwischen Gerät und Schlepper verwenden.

9032.37.01



**T1**

Beleuchtungseinrichtung  
 Light kit  
 Kit d'éclairage

**MegaSeed ab/min./de 4,0m**

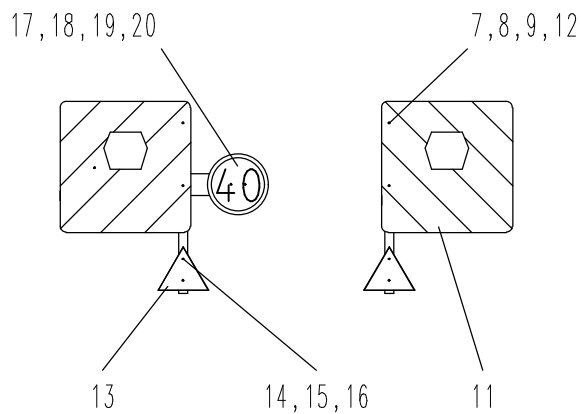
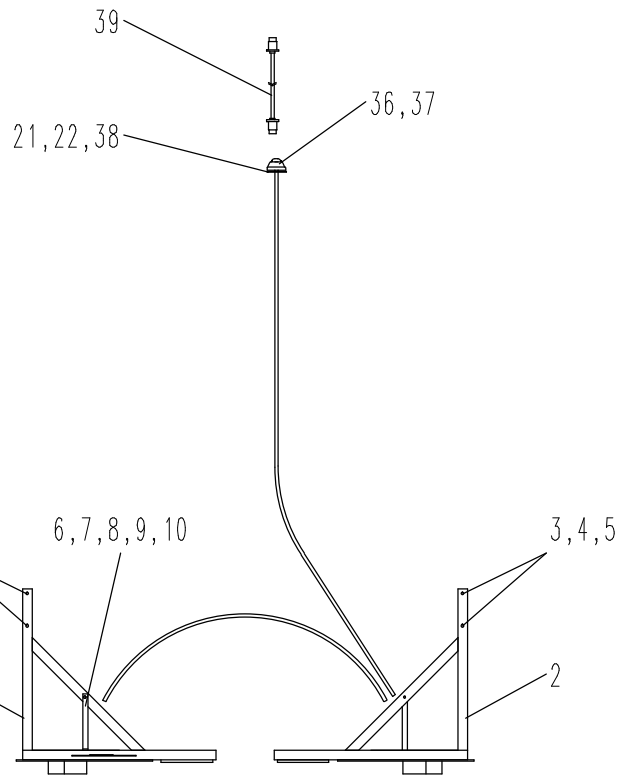
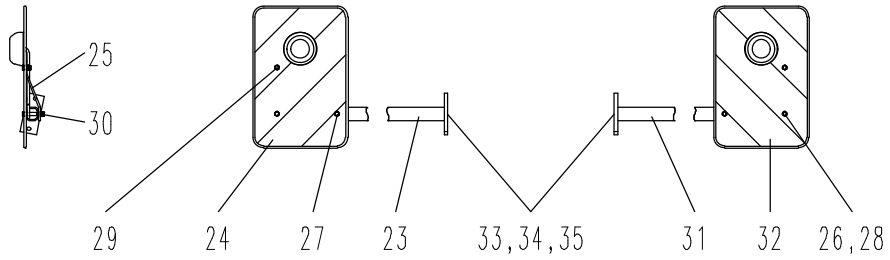



**T1**

Beleuchtungseinrichtung  
Light kit  
Kit d'éclairage

**MegaSeed ab/min./de 4,0 m**

Bild Ref. Fig.	Bestellnr. Part.-No. Référence	Stck Qty. Qte.	Bezeichnung	Technische Angaben Technical data Données techniques	Description	Désignation
1-20	9032.37.10	1	BELEUCHTUNG HINTEN		REAR LIGHT KIT	KIT D'ECLAIRAGE ARRIERE
1	9032.36.01	1	Halterung, links		Bracket l.h.	Support gauche
2	9032.36.02	1	Halterung, rechts		Bracket r.h.	Support droit
3	931D10100PA	4	Sechskantschraube	M10x100 DIN931-8.8 vz.	Hex.bolt	Vis 6 pans
4	125DA10.5A	8	Scheibe	A10,5 DIN125 vz.	Washer	Rondelle
5	980DV10PA	4	Sicherungsmutter	VM10 DIN980-8 vz.	Lock nut	Ecrou frein
6	9032.37.20	2	Abstützung Warntafel		Strut	Support
7	931D850PA	6	Sechskantschraube	M8x50 DIN931-8.8 vz.	Hex.bolt	Vis 6 pans
8	125DA8.4A	12	Scheibe	A8,4 DIN125 vz.	Washer	Rondelle
9	980DV8PA	8	Sicherungsmutter	VM8 DIN980-8 vz.	Lock nut	Ecrou frein
10	933D820PA	2	Sechskantschraube	M8x20 DIN933-8.8 vz.	Hex. bolt	Vis 6 pans
11	9032.37.33	1	Rückleuchte			
12	9021DA8.4A	4	Scheibe	A 8,4 DIN9021 vz.	Washer	Rondelle
13	9032.37.35	2	Rückstrahler			
14	84D545PA	4	Zylinderschraube	M5x45 DIN84-8.8 vz.	Spline screw	Vis cylindrique
15	125DA5.3A	4	Scheibe	A 5,3 DIN125 vz.	Washer	Rondelle
16	980DV5PA	4	Sicherungsmutter	VM5 DIN980-8 vz.	Lock nut	Ecrou frein
17	9032.37.36	1	Kilometerschild	40 km/h		
18	933D615PA	2	Sechskantschraube	M6x15 DIN933-8.8 vz.	Hex.bolt	Vis 6 pans
19	125DA6.4A	2	Scheibe	A 6.4 DIN125 vz.	Washer	Rondelle
20	980DV6PA	2	Sicherungsmutter	VM6 DIN980-8 vz.	Lock nut	Ecrou frein
21-39	9032.37.11	1	BELEUCHTUNG VORNE		FRONT LIGHT KIT	KIT D'ECLAIRAGE AVANT
21	125DA5.3A	3	Scheibe	A 5,3 DIN125 vz.	Washer	Rondelle
22	980DV5PA	3	Sicherungsmutter	VM5 DIN980-8 vz.	Lock nut	Ecrou frein
23-30	6352.40.03	1	BELEUCHT. VORN LINKS		FRONT LIGHT KIT L.H.	KIT D'ECLAIRAGE AV.GAUC
25-32	6352.40.04	1	BELEUCHT. VORN RECHTS		FRONT LIGHT KIT R.H.	KIT D'ECLAIRAGE AV.DROI
23	6352.21.07	1	Beleucht.-Träger, vorn links			
24	6352.39.01	1	Warntafel, vorn links			
25	6352.40.12	1	Abstrebung Warntafel			
26	125DA8.4A	3	Scheibe	A8,4 DIN125 vz.	Washer	Rondelle
27	933D855PA	1	Sechskantschraube	M8x55 DIN933-8.8 vz.	Hex.bolt	Vis 6 pans
28	933D860PA	1	Sechskantschraube	M8x60 DIN933-8.8 vz.	Hex.bolt	Vis 6 pans

